

Medium Voltage Frequency Inverter

MVW-01

User's Manual

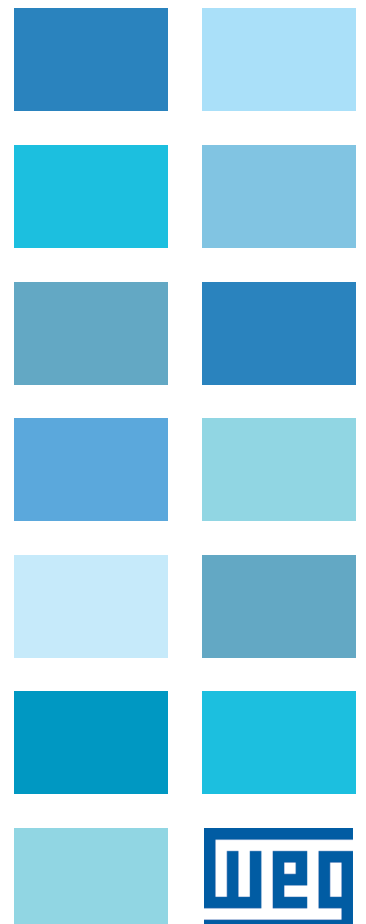



User's Manual

Series: MVW-01

Language: English

Document: 0899.5247 / 03

Publication Date: 09/2015

Version	Review	Description
-	R01	First edition.
-	R02	Addition of the functions: Vector control with encoder. Sensorless vector control. Ride-Through for vector control. Redundant ventilation. Multivariable read-only parameter. WEG protocol at 192000 bps and 38400 bps. Communication protocol for DeviceNet Drive Profile Board. New parameters, new faults and alarms regarding the 4000 HP parallel "Frame C". General revision.
-	R03	Update for the MVW-01 G2 line, firmware version 3.3X. Inclusion of the graphic HMI. Inclusion of the MVW-01C (compact). Inclusion of the 5 level MVW-01. Inclusion of inverter parallelism. Inclusion of the synchronous motor line. Description of special functions. General revision.

QUICK PARAMETER REFERENCE, FAULTS AND STATUS MESSAGES	0-1
I. Parameter.....	0-1
II. Messages of Alarms and Faults	0-25
1 SAFETY NOTICES	1-1
1.1 SAFETY NOTICES IN THE MANUAL	1-1
1.2 SAFETY NOTICES ON THE PRODUCT	1-1
1.3 MVW-01 IDENTIFICATION LABEL	1-2
1.4 PRELIMINARY RECOMMENDATIONS.....	1-2
2 GENERAL INFORMATION	2-1
2.1 ABOUT THIS MANUAL	2-1
2.2 SOFTWARE VERSION	2-1
2.3 HOW TO SPECIFY THE MVW-01 MODEL	2-2
2.3.1 Available Models.....	2-3
2.3.2 MVW-01 Main Components	2-8
2.3.3 MVW-01 Electronic boards	2-11
2.3.4 PLC2 Expansion Board.....	2-11
2.4 RECEIVING AND STORAGE	2-11
3 MVW-01 WITH 3 LEVELS (3L).....	3-1
3.1 MECHANICAL DATA	3-3
3.1.1 Panel Constructive Aspects	3-3
3.2 INPUT RECTIFIER.....	3-4
3.3 INVERTER ARMS.....	3-5
3.4 CONTROL RACK	3-7
3.5 OUTPUT FILTERS	3-8
3.5.1 Sinusoidal Output Filter	3-9
3.6 AVAILABLE MODELS	3-10
4 MVW-01 WITH 5 LEVELS (5L).....	4-1
4.1 MECHANICAL DATA	4-2
4.2 AVAILABLE MODELS	4-2
5 MVW-01C (COMPACT)	5-1
5.1 PANEL CONSTRUCTIVE DETAILS	5-6
5.2 AVAILABLE MODELS	5-7
6 INVERTER PARALLELISM	6-1
6.1 STRUCTURE OF THE PARALLEL INVERTER	6-1
6.2 THREE LEVEL (3L) LINE WITH UP TO FOUR SET PARALLELISM (3L4).....	6-1
6.3 PARALLELISM OF 2 FRAME D OR 2 FRAME E WITH MASTER/SLAVE RACK.....	6-2
6.4 FIVE LEVEL (5L) PARALLELISM LINE	6-4
7 SYNCHRONOUS MOTOR LINE	7-1
7.1 ABSOLUTE ENCODER WITH RSSI BOARD.....	7-1
7.1.1 Absolute Encoder	7-1
7.1.2 RSSI Board.....	7-2
7.2 FIELD EXCITATION SET (DC WITH BRUSHES)	7-3

8	INSTALLATION, CONNECTION AND ENERGIZATION	8-1
8.1	MECHANICAL INSTALLATION	8-1
8.1.1	Environmental Conditions	8-1
8.1.2	Handling Recommendations.....	8-2
8.1.3	Hoisting.....	8-2
8.1.4	Moving.....	8-3
8.1.5	Unpacking.....	8-3
8.1.6	Positioning/Mounting.....	8-5
8.1.7	Power Arm Insertion.....	8-6
8.1.8	Power Arm Electric and Fiber Optic Connections.....	8-8
8.1.9	Insertion of the MVW-01C Power Arms	8-9
8.2	ELECTRICAL INSTALLATION	8-12
8.2.1	Power Section.....	8-12
8.2.2	Input Circuit Breaker	8-15
8.2.3	Low Voltage Auxiliary Supply	8-16
8.3	ENERGIZATION, START-UP AND SAFE DE-ENERGIZATION	8-17
8.3.1	Pre-power Checks.....	8-17
8.3.2	Initial Power-up (Parameter Settings)	8-18
8.3.3	Start-up	8-18
8.3.3.1	Start-up with HMI Operation and V/F 60 Hz Control Mode	8-18
8.3.4	Safe De-energization Instructions.....	8-19
9	KEYPAD (HMI) OPERATION	9-1
9.1	INSTALLATION OF THE GRAPHIC HMI IN THE CABINET	9-2
9.2	STARTING THE USE OF THE GRAPHIC HMI.....	9-2
9.2.1	Graphic HMI Basic Visualization Modes	9-3
9.2.2	Structure of the Parameter Groups	9-4
9.2.3	Sequential Access Mode.....	9-5
9.2.4	Parameter Groups Access Mode	9-6
9.3	PARAMETER EDITION	9-7
9.3.1	Numerical	9-7
9.3.2	Alphanumeric.....	9-7
9.4	CONFIGURING THE GRAPHIC HMI.....	9-8
9.4.1	LCD Contrast.....	9-8
9.4.2	Configuring the HMI Commands.....	9-8
9.4.3	Configuring the Monitoring Mode Read-Only Parameters	9-8
9.4.4	Configuring the On-Line Graphic (Watch) Function.....	9-9
9.5	ALARMS AND FAULTS	9-10
9.5.1	Alarm/Fault Screen.....	9-10
9.5.2	Note Screen	9-10
9.5.3	Error Log.....	9-11
9.6	HELP FUNCTION	9-12
10	OPTIONAL ACCESSORIES AND BOARDS	10-1
10.1	MVC4 SIGNAL AND CONTROL CONNECTIONS	10-1
10.2	FUNCTION EXPANSION BOARDS	10-4
10.2.1	EBA (I/O Expansion Board A)	10-5
10.2.2	EBB (I/O Expansion Board B).....	10-8
10.2.3	PLC2.....	10-12
10.3	INCREMENTAL ENCODER	10-13
10.3.1	EBA/EBB Boards	10-13
10.3.2	EBC1 Board.....	10-15
10.4	SHORT UPS MODULE	10-18
10.4.1	CFW10 Inverter Parameterization.....	10-18
10.5	MVC3 CONTROL BOARD CONNECTIONS.....	10-19

11 DETAILED PARAMETER DESCRIPTION.....	11-1
11.1 ACCESS AND READ ONLY PARAMETERS - P000 to P099	11-1
11.2 REGULATION PARAMETERS - P100 to P199.....	11-16
11.3 CONFIGURATION PARAMETERS - P200 to P399	11-35
11.4 MOTOR PARAMETERS - P400 TO P489.....	11-81
11.5 PARAMETERS OF THE SYNCHRONOUS MOTOR - P427 TO P465.....	11-83
11.6 PARAMETER OF THE GRAPHIC HMI - P490 TO P519	11-90
11.7 PARAMETERS OF THE PID FUNCTION - P520 TO P535	11-92
11.8 PARAMETERS OF THE TRACE FUNCTION.....	11-96
11.9 PARAMETERS OF THE MVC3 ANALOG OUTPUTS - P652 TO P666	11-102
11.10 PARAMETERS OF THE MVC4 ANALOG INPUT AI5.....	11-104
11.11 OTHER MVW-01 PARAMETERS	11-104
12 SPECIAL FUNCTIONS	12-1
12.1 Trace Function	12-1
12.1.1 Trigger	12-1
12.1.2 Data Access.....	12-1
12.1.3 Memory	12-2
12.1.4 Sampling	12-3
12.1.5 Pre-Trigger	12-3
12.1.6 Trace Function Use and Programming Example	12-4
12.1.7 Example of Use and Trigger Configuration	12-5
12.2 PID Regulator.....	12-6
12.3 LOAD SHARE FUNCTION "MASTER/SLAVE".....	12-9
12.4 SYNCHRONOUS TRANSFER OR SYNCHRONOUS BYPASS FUNCTION.....	12-11
12.5 SAFETY STOP FUNCTION	12-13
13 COMMUNICATION NETWORKS.....	13-1
13.1 FIELDBUS KIT	13-1
13.1.1 Installation of the Fieldbus Kit.....	13-1
13.1.2 Profibus DP.....	13-2
13.1.3 DeviceNet.....	13-5
13.1.4 DeviceNet Drive Profile	13-7
13.1.5 Ethernet.....	13-7
13.1.6 Fieldbus Application/MVW-01 Related Parameters.....	13-7
13.1.6.1 Variables Read From the Inverter	13-8
13.1.6.2 Variables Written in Inverter.....	13-9
13.1.6.3 Error Indications.....	13-11
13.1.6.4 MVW-01 Variable Addressing at the Fieldbus Devices.....	13-12
13.2 WEGBUS SERIAL.....	13-12
13.2.1 Protocol Definitions.....	13-15
13.2.2 Variable Code	13-16
13.2.3 MVW-01 Special Parameters	13-20
13.2.4 RS-232 and RS-485 Physical Connection	13-22
13.3 MODBUS-RTU.....	13-23
13.3.1 Introduction to the Modbus-RTU Protocol.....	13-23
13.3.1.1 Transmission Modes	13-23
13.3.1.2 RTU Mode Message Structure	13-24
13.3.2 Operation of the MVW-01 in the Modbus-RTU Network	13-25
13.3.3 Detailed Description of the Functions	13-29
13.3.3.1 Function 01 - Read Coils	13-29
13.3.3.2 Function 03 - Read Holding Register	13-30
13.3.3.3 Function 05 - Write Single Coil	13-31
13.3.3.4 Function 06 - Write Single Register	13-31
13.3.3.5 Function 15 - Write Multiple Coils	13-32
13.3.3.6 Function 16 - Write Multiple Registers.....	13-33
13.3.3.7 Function 43 - Read Device Identification.....	13-33
13.3.4 ModBus RTU Communication Error	13-35

14 DIAGNOSTICS AND TROUBLESHOOTING	14-1
14.1 ALARMS/FAULTS AND POSSIBLE CAUSES	14-1
14.2 INFORMATION FOR CONTACTING TECHNICAL SUPPORT	14-12
14.3 PREVENTIVE MAINTENANCE	14-12
14.3.1 Preventive Maintenance During the Operation.....	14-13
14.3.2 Preventive Maintenance with Complete Stop/De-energization.....	14-14
14.4 SAFE DE-ENERGIZATION INSTRUCTIONS	14-15
14.5 GENERAL WARRANTY CONDITIONS FOR MVW-01 FREQUENCY INVERTERS	14-16

QUICK PARAMETER REFERENCE, FAULTS AND STATUS MESSAGES

Software: V3.3X
 Application:
 Model:
 Serial number:
 Responsible:
 Date: / / .

I. Parameter

Param.	Description	Adjustable Range	Factory Setting	Unit Setting	Group	Pag.
P000	Access Parameter	0 to 999	0	-		11-1
Read Only Parameters P001 to P099						
P001	Speed Reference	P133 to P134	-	rpm	02	11-2
P002	Motor Speed	0 to P134	-	rpm		11-2
P003	Motor Current	0 to 3705 A	-	A		11-2
P004	DC Link Voltage	0 to 8000	-	V		11-2
P005	Motor Frequency	0.0 to 300.0	-	Hz		11-2
P006	Inverter Status	0 to 28	-	-		11-2
P007	Motor Voltage	0 to 8000	-	V		11-4
P009	Motor Torque	0.0 to 250.0	-	%		11-4
P010	Output Power	0 to 9999	-	kW		11-5
P011	Current Inverter	0 to 2600	-	A		11-5
P012	Digital Inputs Status DI1 to DI10 (MVC4 and optional board)	A = Active I = Inactive	-	-		11-5
P013	Digital Outputs Status DO1, DO2 and Relays RL1, RL2, RL3, RL4 and RL5 (MVC4 and optional board)	A = Active I = Inactive	-	-		11-6
P014	Last Fault	0 to 255	-	-		11-6
P015	Second Fault	0 to 255	-	-		11-6
P016	Third Fault	0 to 255	-	-		11-6
P017	Fourth Fault	0 to 255	-	-		11-6
P018	Analog Input AI1' (Unipolar, Board MVC4)	0.0 to 100.0	-	%		11-6
P019	Analog Input AI2' (Bipolar, Board MVC4)	-100.0 to +100.0	-	%		11-6
P020	Analog Input AI3' (Board EBB)	-100.0 to +100.0	-	%		11-6
P021	Analog Input AI4' (Board EBA)	-100.0 to +100.0	-	%		11-6
P022	MVC3 Board Temperature	0 to 100	-	°C		11-6
P023	MVC4 Software Version	XX.X	-	-		11-6
P024	A/D Conversion Value of AI4	-32768 to +32767	-	-		11-6
P025	A/D Conversion Value of Iv	0 to 4095	-	-		11-7
P026	A/D Conversion Value of Iw	0 to 4095	-	-		11-7
P027	A/D Conversion Value of Iu	0 to 4095	-	-		11-7
P028	Input AI5 ' (Isolated Unipolar, board MVC4)	0.0 to 100.0	-	%		11-7
P029	Trace Function Status	0 = Inactive 1 = Waiting for Trigger 2 = Trigger Occurred 3 = Trace Completed	0	-		11-7
P030	Temperature Register CH 1	0 to 240	-	°C		11-8
P031	Temperature Register CH 2	0 to 240	-	°C	11-8	
P032	Temperature Register CH 3	0 to 240	-	°C	11-8	
P033	Temperature Register CH 4	0 to 240	-	°C	11-8	
P034	Temperature Register CH 5	0 to 240	-	°C	11-8	
P035	Temperature Register CH 6	0 to 240	-	°C	11-8	
P036	Temperature Register CH 7	0 to 240	-	°C	11-8	
P037	Temperature Register CH 8	0 to 240	-	°C	11-8	
P040	PID Process Variable	0 to P528	-	%	11-8	

Param.	Description	Adjustable Range	Factory Setting	Unit Setting	Group	Pag.
P041	Active Redundant Ventilation Set	0 = Set A 1 = Set B 2 = Set A xBx 3 = Set B xAx 4 = Set A xABx 5 = Set B xABx 6 = Automatic Test A 7 = Automatic Test B	0	-	02	11-9
P042	Energized Hours Counter	0 to 65530	-	h		11-9
P043	Enabled Hours Counter	0 to 6553	-	h		11-9
P044	MWh Counter	0 to 11930	-	MWh		11-9
P045	HMI Software Version	XX.X	-	-		11-9
P046	Junction Temperature	-20.0 to +200.0	-	°C		11-9
P047	Temperature Phase UAp	-20.0 to 200.0	-	°C		11-10
P048	Temperature Phase VAp	-20.0 to 200.0	-	°C		11-10
P049	Temperature Phase WAp	-20.0 to 200.0	-	°C		11-10
P050	BR. F. p Temperature	-20.0 to 200.0	-	°C		11-10
P051	1p Rectifier Temperature	-20.0 to 200.0	-	°C		11-10
P052	DC Link Negative Voltage	0 to 8000	-	V		11-10
P053	DC Link Positive Voltage	0 to 8000	-	V		11-10
P055	U Phase Temperature	-20.0 to +200.0	-	°C		11-10
P056	V Phase Temperature	-20.0 to +200.0	-	°C		11-10
P057	W Phase Temperature	-20.0 to +200.0	-	°C		11-10
P058	Temperature Arm of the Braking Circuit	-20.0 to +200.0	-	°C		11-11
P059	Rectifier Temperature	-20.0 to +200.0	-	°C		11-11
P060	Fifth Fault	0 to 255	-	-		11-11
P061	Sixth Fault	0 to 255	-	-		11-11
P062	Seventh Fault	0 to 255	-	-		11-11
P063	Eighth Fault	0 to 255	-	-		11-11
P064	Ninth Fault	0 to 255	-	-		11-11
P065	Tenth Fault	0 to 255	-	-		11-11
P066	MVC3 Software Version	XX.X	-	-		11-11
P067	Error Log	1 to 100	-	-		11-11
P070	MVC3 DI Status	A = Active I = Inactive	-	-		11-12
P071	MVC3 DO Status	A = Active I = Inactive	-	-		11-12
P072	Vab Input Voltage	-8000 to +8000	-	V		11-12
P073	Vcb Input Voltage	-8000 to +8000	-	V		11-12
P074	Voltage Modulus of Input Transformer Secondary	0 to 3750	-	V		11-12
P075	Medium Point to Ground Voltage	0.0 to 100.0	-	%		11-12
P076	Overload I x t	0.0 to 150.0	-	%		11-12
P077	Field Current	0 to 999.9	-	A		11-12
P078	Brushless Field Voltage	0 to 9999	-	V		11-12
P079	Position of the Motor Shaft	0 to 360.0°	-	-		11-12
P080	Date	(dd/mm/yy)	-	d		11-13
P081	Hour	Format 24 h	-	s		11-13
P082	Temperature Phase UB	-20.0 to 200.0	-	°C		11-14
P083	Temperature Phase VB	-20.0 to 200.0	-	°C		11-14
P084	Temperature Phase WB	-20.0 to 200.0	-	°C		11-14
P085	Temperature Phase UBp	-20.0 to 200.0	-	°C		11-14
P086	Temperature Phase VBp	-20.0 to 200.0	-	°C		11-14
P087	Temperature Phase WBp	-20.0 to 200.0	-	°C		11-14
P088	Temperature Rectifier 2	-20.0 to 200.0	-	°C		11-14
P089	Temperature Rectifier 3	-20.0 to 200.0	-	°C		11-14
P092	Voltage Negative DC Link of Phase V	0 to 8000	-	V		11-15
P093	Voltage Positive DC Link of Phase V	0 to 8000	-	V	11-15	

Param.	Description	Adjustable Range	Factory Setting	Unit Setting	Group	Pag.
P094	Voltage Negative DC Link of Phase W	0 to 8000	-	V	02	11-15
P095	Voltage Positive DC Link of Phase W	0 to 8000	-	V		11-15
Parameters of Regulation P100 to P199						
Ramps						
P100	Acceleration Time	0.0 to 999.0	100.0	s	20	11-16
P101	Deceleration Time	0.0 to 999.0	180.0	s		11-16
P102	Acceleration Time 2 nd Ramp	0.0 to 999.0	100.0	s		11-16
P103	Deceleration Time 2 nd Ramp	0.0 to 999.0	180.0	s		11-16
P104	S Ramp	0.0 to 100.0	0.0	%		11-16
P119	Reactive Power reference of the Power Factor Control	-99.99 to 99.99	-	%		11-17
Speed References						
P120	Speed Reference Backup	0 = Inactive 1 = Active	1	-		11-17
P121	Keypad Reference	P133 to P134	90	rpm		11-17
P122 ⁽²⁾	JOG or JOG+ Speed Reference	0 to P134	150	rpm		11-17
P123 ⁽²⁾	JOG- Speed Reference	0 to P134	150	rpm		11-17
P124 ⁽²⁾	Multispeed Reference 1	P133 to P134	90	rpm	35	11-18
P125 ⁽²⁾	Multispeed Reference 2	P133 to P134	300	rpm		11-18
P126 ⁽²⁾	Multispeed Reference 3	P133 to P134	600	rpm		11-18
P127 ⁽²⁾	Multispeed Reference 4	P133 to P134	900	rpm		11-18
P128 ⁽²⁾	Multispeed Reference 5	P133 to P134	1200	rpm		11-18
P129 ⁽²⁾	Multispeed Reference 6	P133 to P134	1500	rpm		11-18
P130 ⁽²⁾	Multispeed Reference 7	P133 to P134	1800	rpm		11-18
P131 ⁽²⁾	Multispeed Reference 8	P133 to P134	1650	rpm		11-18
Speed Limits						
P132	Over Speed Level	0 to 100	10	%		11-19
P133 ⁽²⁾	Minimum Speed Reference	0 to (P134 - 1)	90	rpm		11-20
P134 ⁽²⁾	Maximum Speed Reference	(P133 + 1) to (3.4 x P402)	1800	rpm		11-20
Control V/F						
P136	Manual Torque Boost (I x R)	0 to 100	0	-		11-21
P137	Automatic Torque Boost	0.000 to 1.000	0.000	-		11-22
P138 ⁽²⁾	Slip Compensation	-10.00 to +10.00	0.00	%		11-23
P139	Output Current Filter	0.0 to 16.0	0.2	s		11-24
Redundant Ventilation						
P140	Redundant Ventilation Selection	0 = Inactive 1 = Set A 2 = Set B 3 = Alternating A 4 = Alternating B	0	-		11-25
P141	Time Interval Between Set Alternating	1 to 9999	720	h		11-25
Control V/F Adjustable						
P142 ⁽¹⁾	Maximum Output Voltage	0.0 to 100.0	100.0	%		11-26
P143 ⁽¹⁾	Intermediate Output	0.0 to 100.0	50.0	%		11-26
P144 ⁽¹⁾	Output Voltage in 3 Hz	0.0 to 100.0	8.0	%		11-26
P145 ^{(1) (2)}	Field Weakening Speed	P133 (>90) to P134	1800	rpm		11-26
P146 ^{(1) (2)}	Intermediate Speed	90 to P145	900	rpm		11-26
DC Link Voltage Regulation						
P150 ⁽¹⁾	DC Link Voltage Regulation Mode	0 to 2	2	-		11-27
P151 ⁽⁴⁾	DC Link Voltage Regulation Level	325 to 400 (P296 = 0 = 220 V) 564 to 800 (P296 = 1 = 380 V) 3541 to 4064 (P296 = 2 = 2300 V) 5080 to 5831 (P296 = 3 = 3300 V) 6404 to 7350 (P296 = 4 = 4160 V) 5200 to 6500 (P296 = 5 = 5872 V) 7081 to 8127 (P296 = 6 = 4600 V)	375 (P296 = 0) 618 (P296 = 1) 3571 (P296 = 2) 5123 (P296 = 3) 6428 (P296 = 4) 6000 (P296 = 5) 7107 (P296 = 6)	V		11-28
P152	Proportional Gain	0.00 to 9.99	0.00	-		11-30

Param.	Description	Adjustable Range	Factory Setting	Unit Setting	Group	Pag.
P153 ⁽⁴⁾	Dynamic Braking Level	325 to 400 (P296 = 0 = 220 V) 564 to 800 (P296 = 1 = 380 V) 3541 to 4064 (P296 = 2 = 2300 V) 5080 to 5831 (P296 = 3 = 3300 V) 6404 to 7350 (P296 = 4 = 4160 V) 7081 to 8127 (P296 = 6 = 4600 V)	375 (P296 = 0) 618 (P296 = 1) 3571 (P296 = 2) 5123 (P296 = 3) 6428 (P296 = 4) 7107 (P296 = 6)	V		11-30
P154	Braking Resistor	0.0 to 500.0	0.0	Ω		11-30
P155	Permitted Power Braking Resistor	10 to 1500	50	kW		11-31
Overload Current						
P156 ^{(2) (5)}	Overload Current 100 %	P157 x P295 to 1.2 x P295	1.1 x P401	A		11-31
P157 ^{(2) (5)}	Overload Current 50 %	P158 to P156	0.9 x P401	A		11-31
P158 ^{(2) (5)}	Overload Current 5 %	0.2 x P295 to P157	0.5 x P401	A		11-31
P159	Temperature Alarm I x t	0 to 100	80	%		11-32
Current Regulator						
P161	Speed Regulator Proportional Gain	0.0 to 200.0	20.0	-		11-32
P162	Speed Regulator Integral Gain	1 to 9999	100	-		11-32
P163	Local Reference Offset	-999 to +999	0	-		11-32
P164	Remote Reference Offset	-999 to +999	0	-		11-32
P165	Speed Filter	0.001 to 1.000	0.012	s		11-32
P167	Current Regulator Proportional Gain	0.000 to 9.999	0.080	-		11-33
P168	Current Regulator Integral Gain	0.1 to 999.9	12.3	-		11-33
P169 (Vector)	Maximum Output Current (V/F Control)	0.2 x P295 to 1.5 x P295	1.35 x P295	A		11-33
P170	Maximum Forward Torque Current	0 to (P295 / P401) x 150	105	%		11-33
P171 (Vector)	Maximum Reverse Torque Current	0 to (P295 / P401) x 150	105	%		11-33
Flux Regulator						
P175 ⁽¹⁾	Flux Regulator Proportional Gain	0.0 to 999.9	50.0	-		11-34
P176 ⁽³⁾	Integration Constant of the Flux Regulator	1 to 9999	900	-		11-34
P177	Minimum Flux	0 to 120	0	%		11-34
P178	Nominal Flux	0 to 120	100	%		11-34
P179	Maximum Flux	0 to 200	120	%		11-34
P180	Field Weakening Starting Point	0 to 120	85	%		11-34
P181	Magnetization Mode	0 = General Enabling 1 = Start/Stop	0	-		11-34
P182	Flux Reference Regulator Proportional Gain	0.00 to 99.99	0.20	-		11-35
P183	Flux Reference Regulator Integral Gain	1 to 9999	25	-		11-35
Configuration Parameters P200 to P399						
P200	Password	0 = Inactive 1 = Active	1	-		11-35
P201	Language Selection	0 = Portuguese 1 = English 2 = Spanish 3 = German	To be defined by the user	-		11-35
P202 ^{(1) (2)}	Type of Control	0 = V/F 60 Hz 1 = V/F 50 Hz 2 = V/F Adjustable 3 = Sensorless Vector 4 = Vector with Encode	0	-		11-36
P203 ⁽¹⁾	Special Functions Selection	0 = None 1 = PID Regulator 2 = Trace 3 = Trace+PID	0	-		11-37

Param.	Description	Adjustable Range	Factory Setting	Unit Setting	Group	Pag.
P204 ⁽¹⁾	Load / Save Parameters	0 = Not Used 1 = Not Used 2 = Not Used 3 = Reset P043 4 = Reset P044 5 = Load WEG 60 Hz 6 = Not Used 7 = Loads User 1 8 = Loads User 2 9 = Not Used 10 = Save User 1 11 = Save User 2	0	-		11-37
P206	Auto-Reset Time	0 to 255	0	s		11-38
P208 ⁽²⁾	Reference Scale Factor	1 to 18000	1800	-		11-39
P209	Motor Phase Loss Detection	0 = Inactive 1 = Active	0	-		11-39
P211	Disable by N = 0 (Stop Logic)	0 = Inactive 1 = Active	1	-		11-40
P212	Disable Output N = 0 (Stop Logic)	0 = P001 (N*) > P291 or P002 (N) > P291 1 = P001 (N*) > 0	0	-		11-40
P213	Time Delay for Zero Speed Disable	0 to 999	0	s		11-40
P214 ⁽¹⁾⁽⁶⁾	Line Phase Loss Detection	0 = Inactive 1 = Active	1	-		11-40
P215 ⁽¹⁾	Keypad Copy Function	0 = Inactive 1 = INV → HMI 2 = HMI → INV	0	-		11-41
Definition Local / Remote						
P220 ⁽¹⁾	LOCAL / REMOTE Selection Source	0 = Always LOC 1 = Always REM 2 = HMI (L) 3 = HMI (R) 4 = DI2 to DI10 5 = Serial (L) 6 = Serial (R) 7 = Fieldbus (L) 8 = Fieldbus (R) 9 = PLC (L) 10 = PLC (R) 11 = Graphic HMI (LOC) 12 = Graphic HMI (REM)	11	-		11-43
P221 ⁽¹⁾	LOCAL Speed Reference Selection	0 = HMI (Keys) 1 = AI1 2 = AI2 3 = AI3 4 = AI4 5 = Sum AI > 0 6 = Sum AI 7 = E.P. 8 = Multispeed 9 = Serial 10 = Fieldbus 11 = AI5 12 = PLC 13 = Graphic HMI	13	-		11-44
P222 ⁽¹⁾	REMOTE Speed Reference Selection	0 = HMI (Keys) 1 = AI1 2 = AI2 3 = AI3 4 = AI4 5 = Sum AI > 0 6 = Sum AI 7 = E.P. 8 = Multispeed 9 = Serial 10 = Fieldbus 11 = AI5 12 = PLC 13 = Graphic HMI	0	-		11-44

Param.	Description	Adjustable Range	Factory Setting	Unit Setting	Group	Pag.
P223 ⁽¹⁾	LOCAL FWD/REV Selection	0 = Always FWD 1 = Always REV 2 = HMI (H) 3 = HMI (AH) 4 = DI2 5 = Serial (H) 6 = Serial (AH) 7 = Fieldbus (H) 8 = Fieldbus (AH) 9 = Polarity AI4 10 = PLC (H) 11 = PLC (AH) 12 = Graphic HMI (H) 13 = Graphic HMI (AH)	12	-		11-44
P224 ⁽¹⁾	LOCAL Start/Stop Selection	0 = Keypad [I] and [O] 1 = DIx 2 = Serial 3 = Fieldbus 4 = PLC 5 = Graphic HMI	5	-		11-45
P225 ⁽¹⁾	LOCAL JOG Selection	0 = Inactive 1 = HMI 2 = DI3 to DI10 3 = Serial 4 = Fieldbus 5 = PLC 6 = Graphic HMI	6	-		11-45
P226 ⁽¹⁾	REMOTE FWD/REV Selection	0 = Forward 1 = Reverse 2 = HMI (H) 3 = HMI (AH) 4 = DI2 5 = Serial (H) 6 = Serial (AH) 7 = Fieldbus (H) 8 = Fieldbus (AH) 9 = Polarity AI4 10 = PLC (H) 11 = PLC (AH) 12 = Graphic HMI (H) 13 = Graphic HMI (AH)	4	-		11-45
P227 ⁽¹⁾	REMOTE Start/Stop Selection	0 = Keypad [I] and [O] 1 = DIx 2 = Serial 3 = Fieldbus 4 = PLC 5 = Graphic HMI	0	-		11-46
P228 ⁽¹⁾	JOG Selection - REMOTE Situation	0 = Inactive 1 = HMI 2 = DI3 to DI10 3 = Serial 4 = Fieldbus 5 = PLC 6 = Graphic HMI	1	-		11-46
Stop Model Definition						
P231	Actuation in the transition between Local and Remote for the HMIG	0 = It keeps the motor state 1 = It keeps the HMI state 2 = It turns off the motor *	0	-		11-51
P232	Stop Mode Selection	0 = Run/Stop 1 = General Disable	0	-		11-51
Analog Inputs						
P233	Analog Inputs Dead Zone	0 = Inactive 1 = Active	1	-		11-51
P234	Analog Input AI1 Gain (Unipolar)	0.000 to 9.999	1.000	-		11-52
P235 ⁽¹⁾	Analog Input AI1 Signal	0 = (0 to 10) V / (0 to 20) mA 1 = (4 to 20) mA 2 = (10 to 0) V / (20 to 0) mA 3 = (20 to 4) mA	0	-		11-53

Param.	Description	Adjustable Range	Factory Setting	Unit Setting	Group	Pag.
P236	Analog Input AI1 Offset	-100.0 to +100.0	0.0	%		11-53
P237 ⁽¹⁾	Analog Input AI2 Function (Bipolar)	0 = P221/P222 1 = Not Used 2 = Maximum Torque Current 3 = Process Variable PID	0	-		11-53
P238	Analog Input AI2 Gain	0.000 to 9.999	1.000	-		11-53
P239 ⁽¹⁾	Analog Input AI2 Signal	0 = (0 to 10) V / (0 to 20) mA 1 = (4 to 20) mA 2 = (10 to 0) V / (20 to 0) mA 3 = (20 to 4) mA 4 = (-10 to +10) V	0	-		11-54
P240	Analog Input AI2 Offset	-100.0 to +100.0	0.0	%		11-54
P241 ⁽¹⁾	Analog Input AI3 Function (Expansion)	0 = P221/P222 1 = Not Used 2 = Maximum Torque Current 3 = Variable Process PID	0	-		11-54
P242	Analog Input AI3 Gain	0.000 to 9.999	1.000	-		11-54
P243 ⁽¹⁾	Analog Input AI3 Signal	0 = (0 to 10) V / (0 to 20) mA 1 = (4 to 20) mA 2 = (10 to 0) V / (20 to 0) mA 3 = (20 to 4) mA	0	-		11-55
P244	Analog Input AI3 Offset	-100.0 to +100.0	0.0	%		11-55
P245	Analog Input AI4 Gain (Expansion)	0.000 to 9.999	1.000	-		11-55
P246 ⁽¹⁾	Analog Input AI4 Signal	0 = (0 to 10) V / (0 to 20) mA 1 = (4 to 20) mA 2 = (10 to 0) V / (20 to 0) mA 3 = (20 to 4) mA 4 = (-10 to +10) V	0	-		11-55
P247	Analog Input AI4 Offset	-100.0 to +100.0	0.0	%		11-55
P248	Input Filter AI2	0.0 to 16.0	0.0	s		11-55
Analog Outputs						
P251	Analog Output AO1 Function	0 = Speed Reference 1 = Total Reference 2 = Real Speed 3 = Not Used 4 = Not Used 5 = Output Current 6 = PID Process Variable 7 = Active Current (V/F) 8 = Output Power 9 = PID Setpoint 10 = Not Used 11 to 18 = Trace Channels 1 to 8 19 = Inverter Temperature 20 = PLC 21 = Output Voltage	2	-		11-56
P252	Analog Output AO1 Gain	0.000 to 9.999	1.000	-		11-56
P253	Analog Output AO2 Function	0 = Speed Reference 1 = Total Reference 2 = Real Speed 3 = Not Used 4 = Not Used 5 = Output Current 6 = PID Process Variable 7 = Active Current (V/F) 8 = Output Power 9 = PID Setpoint 10 = Not Used 11 to 18 = Trace Channels 1 to 8 19 = Inverter Temperature 20 = PLC 21 = Output Voltage	5	-		11-56
P254	Analog Output AO2 Gain	0.000 to 9.999	1.000	-		11-56

Param.	Description	Adjustable Range	Factory Setting	Unit Setting	Group	Pag.
P255	Analog Output AO3 Function (Use Expansion Board EBA)	0 = Speed Reference 1 = Total Reference 2 = Real Speed 3 = Not Used 4 = Not Used 5 = Output Current 6 = PID Process Variable 7 = Active Current (V/F) 8 = Output Power 9 = PID Setpoint 10 = Not Used 11 to 18 = Trace Channels 1 to 8 19 = Inverter Temperature 20 = PLC 21 = Output Voltage	2	-		11-56
P256	Analog Output AO3 Gain	0.000 to 9.999	1.000	-		11-56
P257	Analog Output AO4 Function (Use Expansion Board EBA)	0 = Speed Reference 1 = Total Reference 2 = Real Speed 3 = Not Used 4 = Not Used 5 = Output Current 6 = PID Process Variable 7 = Output Active Current (V/F) 8 = Output Power 9 = PID Setpoint 10 = Not Used 11 to 18 = Trace Channels 1 to 8 19 = Inverter Temperature 20 = PLC 21 = Output Voltage	5	-		11-56
P258	Analog Output AO4 Gain	0.000 to 9.999	1.000	-		11-56
P259	Analog Output AO5 Function (Isolated unipolar)	0 = Speed Reference 1 = Total Reference 2 = Real Speed 3 = Not Used 4 = Not Used 5 = Output Current 6 = PID Process Variable 7 = Output Active Current (V/F) 8 = Output Power 9 = PID Setpoint 10 = Not Used 11 to 18 = Trace Channels 1 to 8 19 = Inverter Temperature 20 = PLC 21 = Output Voltage	2	-		11-57
P260	Analog Output AO5 Gain	0.000 to 9.999	1.000	-		11-57
P261	Analog Output AO6 Function (Isolated unipolar)	0 = Speed Reference 1 = Total Reference 2 = Real Speed 3 = Not Used 4 = Not Used 5 = Output Current 6 = PID Process Variable 7 = Output Active Current (V/F) 8 = Output Power 9 = PID Setpoint 10 = Not Used 11 to 18 = Trace Channels 1 to 8 19 = Inverter Temperature 20 = PLC 21 = Output Voltage	5	-		11-57
P262	Analog Output AO6 Gain	0.000 to 9.999	1.000	-		11-57
Digital Inputs						
P263 ⁽¹⁾	Digital Input DI1 Function	0 = Not Used 1 = Run/Stop 2 = General Enable 3 = Stop by Ramp	0	-		11-59

Param.	Description	Adjustable Range	Factory Setting	Unit Setting	Group	Pag.
P264 ⁽¹⁾	Digital Input DI2 Function	0 = FWD/REV 1 = Local / Remote	0	-		11-59
P265 ⁽¹⁾	Digital Input DI3 Function	0 = Not Used 1 = Local / Remote 2 = General Enable 3 = JOG 4 = No External Fault 5 = Increase E.P. 6 = 2 nd Ramp 7 = Not Used 8 = Forward Run 9 = Sinusoidal Filter Circuit Breaker 10 = JOG+ 11 = JOG- 12 = Reset 13 = Fieldbus 14 = Start 115 = Manual/Auto 16 = No External Alarm 17 = Not Used 18 = Not Used 19 = Parametrization Allowed 20 = Load User 1 and 2 21 = RL2 Timer 22 = RL3 Timer 23 = No Alarm at Redundant Fan Set A 24 = No Alarm at Redundant Fan Set B 25 = Initiates Synchronous Transfer 26 = Ventilation OK	0	-		11-59
P266 ⁽¹⁾	Digital Input DI4 Function	0 = Not Used 1 = Local / Remote 2 = General Enable 3 = JOG 4 = No External Fault 5 = Decrease E.P. 6 = 2 nd Ramp 7 = Multispeed 8 = Reverse 9 = Sinusoidal Filter Circuit Breaker 10 = JOG+ 11 = JOG- 12 = Reset 13 = Fieldbus 14 = Stop 15 = Manual/Auto 16 = No External Alarm 17 = Not Used 18 = Not Used 19 = Parameterization Disabling 20 = Loads User 1 and 2 21 = RL2 Timer 22 = RL3 Timer 23 = No Alarm at Redundant Fan Set A 24 = No Alarm at Redundant Fan Set B 25 = Initiates Synchronous Transfer 26 = Ventilation OK	0	-		11-59

Param.	Description	Adjustable Range	Factory Setting	Unit Setting	Group	Pag.
P267 ⁽¹⁾	Digital Input DI5 Function	0 = Not Used 1 = Local / Remote 2 = General Enable 3 = JOG 4 = No External Fault 5 = Increase E.P. 6 = 2 nd Ramp 7 = Multispeed 8 = Ramp Stop 9 = Sinusoidal Filter Circuit Breaker 10 = JOG+ 11 = JOG- 12 = Reset 13 = Fieldbus 14 = Start 15 = Manual/Auto 16 = No External Alarm 17 = Not Used 18 = Not Used 19 = Parameterization Disabling 20 = Load User 1 and 2 21 = RL2 Timer 22 = RL3 Timer 23 = No Alarm at Redundant Fan Set A 24 = No Alarm at Redundant Fan Set B 25 = Initiates Synchronous Transfer 26 = Ventilation OK	3	-		11-59
P268 ⁽¹⁾	Digital Input DI6 Function	0 = Not Used 1 = Local / Remote 2 = General Enable 3 = JOG 4 = No External Fault 5 = Decrease E.P. 6 = 2 nd Ramp 7 = Multispeed 8 = Ramp Stop 9 = Sinusoidal Filter Circuit Breaker 10 = JOG+ 11 = JOG- 12 = Reset 13 = Fieldbus 14 = Stop 15 = Manual/Auto 16 = No External Alarm 17 = Not Used 18 = Not Used 19 = Parameterization Disabling 20 = Load User 1 and 2 21 = RL2 Timer 22 = RL3 Timer 23 = No Alarm at Redundant Fan Set A 24 = No Alarm at Redundant Fan Set B 25 = Initiates Synchronous Transfer 26 = Ventilation OK	6	-		11-59

Param.	Description	Adjustable Range	Factory Setting	Unit Setting	Group	Pag.
P269 ⁽¹⁾	Digital Input DI7 Function (use Expansion Board)	0 = Not Used 1 = Local/Remote 2 = General Enable 3 = JOG 4 = No External Fault 5 = Not Used 6 = 2 nd Ramp 7 = Not Used 8 = Ramp Stop 9 = Not Used 10 = JOG+ 11 = JOG- 12 = Reset 13 = Fieldbus 14 = Start 15 = Manual/Auto 16 = Not Used 17 = Not Used 18 = Not Used 19 = Parameterization Disabling 20 = Load User 1 and 2 21 = RL2 Timer 22 = RL3 Timer 23 = Initiates Synchronous Transfer 24 = Ventilation OK	0	-		11-59
P270 ⁽¹⁾	Digital Input DI8 Function (use Expansion Board)	0 = Not Used 1 = Local/Remote 2 = General Enable 3 = JOG 4 = No External Fault 5 = Not Used 6 = 2 nd Ramp 7 = Not Used 8 = Ramp Stop 9 = Not Used 10 = JOG+ 11 = JOG- 12 = Reset 13 = Fieldbus 14 = Stop 15 = Manual/Auto 16 = Motor Thermistor 17 = Not Used 18 = Not Used 19 = Parameterization Disabling 20 = Loads User 1 and 2 21 = RL2 Timer 22 = RL3 Timer 23 = Initiates Synchronous Transfer 24 = Ventilation OK	0	-		11-59
P271 ⁽¹⁾	Digital Input DI9 Function	0 = Not Used 1 = Local / Remote 2 = General Enable 3 = JOG 4 = No External Fault 5 = Not Used 6 = 2 nd Ramp 7 = Not Used 8 = Ramp Stop 9 = Not Used 10 = JOG+ 11 = JOG- 12 = Reset 13 = Fieldbus 14 = Stop 15 = Manual/Auto 16 = No External Alarm 17 = Not Used 18 = Not Used 19 = No Motor Fault 20 = No Motor Alarm 21 = No Alarm at Redundant Fan Set A 22 = No Alarm at Redundant Fan Set B 23 = Initiates Synchronous Transfer 24 = Ventilation OK	0	-		11-60

Param.	Description	Adjustable Range	Factory Setting	Unit Setting	Group	Pag.
P272 ⁽¹⁾	Digital Input DI10 Function	0 = Not Used 1 = Local/Remote 2 = General Enable 3 = JOG 4 = No External Fault 5 = Not Used 6 = 2 nd Ramp 7 = Not Used 8 = Ramp Stop 9 = Not Used 10 = JOG+ 11 = JOG- 12 = Reset 13 = Fieldbus 14 = Stop 15 = Manual/Auto 16 = No External Alarm 17 = Not Used 18 = Not Used 19 = No Motor Fault 20 = No Motor Alarm 21 = No Alarm at Redundant Fan Set A 22 = No Alarm at Redundant Fan Set B 23 = Initiates Synchronous Transfer 24 = Ventilation OK	0	-		11-60
Digital Outputs						
P275 ⁽¹⁾	Digital Output DO1 Function (use Expansion Board)	0 = Not Used 1 = N* > Nx 2 = N > Nx 3 = N < Ny 4 = N = N* 5 = N = 0 6 = Is > lx 7 = Is < lx 8 = Not Used 9 = Not Used 10 = Remote 11 = Run 12 = Ready 13 = No Fault 14 = No E71 + E70 15 = No E22 + E21 + E06 16 = No E62 17 = No E72 18 = (4 to 20) mA OK 19 = Fieldbus 20 = Forward 21 = Process Variable > VPx 22 = Process Variable < VPy 23 = Not Used 24 = Pre-charge OK 25 = With Fault 26 = N > Nx and Nt > Nx 27 = No Fault, with Delay 28 = No Alarm 29 = Not Used 30 = Redundant Ventilation Selection 31 = Not Used 32 = Circuit Break ON (Input Circuit Breaker ON) 33 = Transfer OK 34 = Synchronism OK 35 = Serial 36 = Safety Stop 37 = Sinusoidal Filter Circuit Breaker 38 = Normal/Slave	0	-		11-66

Param.	Description	Adjustable Range	Factory Setting	Unit Setting	Group	Pag.
P276 ⁽¹⁾	Digital Output DO2 Function (use Expansion Board)	0 = Not Used 1 = N* > Nx 2 = N > Nx 3 = N < Ny 4 = N = N* 5 = N = 0 6 = Is > lx 7 = Is < lx 8 = Not Used 9 = Not Used 10 = Remote 11 = Run 12 = Ready 13 = No Fault 14 = No E71 + E70 15 = No E22 + E21 + E06 16 = No E62 17 = No E72 18 = (4 to 20) mA OK 19 = Fieldbus 20 = Forward 21 = Process Variable > VPx 22 = Process Variable < VPy 23 = Not Used 24 = Pre-charge OK 25 = With Fault 26 = N > Nx and Nt > Nx 27 = Without Error With Delay 28 = No Alarm 29 = Not Used 30 = Redundant Ventilation 31 = Not Used 32 = Circuit Break ON (Input Circuit Breaker ON) 33 = Transference OK 34 = Synchronism OK 35 = Serial 36 = Safety Stop 37 = Sinusoidal Filter Circuit Breaker 38 = Normal/Slave	0	-		11-66

Param.	Description	Adjustable Range	Factory Setting	Unit Setting	Group	Pag.
P277 ⁽¹⁾	Relay Output RL1 Function	0 = Not Used 1 = N* > Nx 2 = N > Nx 3 = N < Ny 4 = N = N* 5 = N = 0 6 = Is > lx 7 = Is < lx 8 = Not Used 9 = Not Used 10 = Remote 11 = Run 12 = Ready 13 = No Fault 14 = No E71 + E70 15 = No E22 + E21 + E06 16 = No E62 17 = No E72 18 = (4 to 20) mA OK 19 = Fieldbus 20 = Forward 21 = Process Variable > VPx 22 = Process Variable < VPy 23 = Not Used 24 = Pre-charge OK 25 = With Fault 26 = N > Nx and Nt > Nx 27 = No Fault, with Delay 28 = No Alarm 29 = Not Used 30 = Redundant Ventilation 31 = PLC 32 = Circuit Break ON (Input Circuit Breaker ON) 33 = Transference OK 34 = Synchronism OK 35 = Serial 36 = Safety Stop 37 = Sinusoidal Filter Circuit Breaker 38 = Normal/Slave	13	-		11-66

Param.	Description	Adjustable Range	Factory Setting	Unit Setting	Group	Pag.
P279 ⁽¹⁾	Relay Output RL2 Function	0 = Not Used 1 = N* > Nx 2 = N > Nx 3 = N < Ny 4 = N = N* 5 = N = 0 6 = Is > lx 7 = Is < lx 8 = Not Used 9 = Not Used 10 = Remote 11 = Run 12 = Ready 13 = No Fault 14 = No E71 + E70 15 = No E22 + E21 + E06 16 = No E62 17 = No E72 18 = (4 to 20) mA OK 19 = Fieldbus 20 = Forward 21 = Process Variable > VPx 22 = Process Variable < VPy 23 = Not Used 24 = Pre-charge OK 25 = With Fault 26 = N > Nx and Nt > Nx 27 = Without error with delay 28 = No Alarm 29 = Timer 30 = Redundant Ventilation 31 = PLC 32 = Circuit Break ON (Input Circuit Breaker ON) 33 = Transference OK 34 = Synchronism OK 35 = Serial 36 = Safety Stop 37 = Sinusoidal Filter Circuit Breaker 38 = Normal/Slave	2	-		11-66

Param.	Description	Adjustable Range	Factory Setting	Unit Setting	Group	Pag.
P280 ⁽¹⁾	Relay Output RL3 Function	0 = Not Used 1 = N* > Nx 2 = N > Nx 3 = N < Ny 4 = N = N* 5 = N = 0 6 = Is > lx 7 = Is < lx 8 = Not Used 9 = Not Used 10 = Remote 11 = Run 12 = Ready 13 = No Fault 14 = No E71 + E70 15 = No E22 + E21 + E06 16 = No E62 17 = No E72 18 = (4 to 20) mA OK 19 = Fieldbus 20 = Forward 21 = Process Variable > VPx 22 = Process Variable < VPy 23 = Not Used 24 = Pre-charge OK 25 = With Fault 26 = N > Nx and Nt > Nx 27 = Without Error With Delay 28 = No Alarm 29 = Timer 30 = Redundant Ventilation 31 = PLC 32 = Circuit Break ON (Input Circuit Breaker ON) 33 = Transference OK 34 = Synchronism OK 35 = Serial 36 = Safety Stop 37 = Sinusoidal Filter Circuit Breaker 38 = Normal/Slave	1	-		11-66

Param.	Description	Adjustable Range	Factory Setting	Unit Setting	Group	Pag.
P281 ⁽¹⁾	Relay Output RL4 Function	0 = Not Used 1 = N* > Nx 2 = N > Nx 3 = N < Ny 4 = N = N* 5 = N = 0 6 = Is > lx 7 = Is < lx 8 = Not Used 9 = Not Used 10 = Remote 11 = Run 12 = Ready 13 = No Fault 14 = No E71 + E70 15 = No E22 + E21 + E06 16 = No E62 17 = No E72 18 = (4 to 20) mA OK 19 = Fieldbus 20 = Forward 21 = Process Variable > VPx 22 = Process Variable < VPy 23 = Not Used 24 = Pre-charge OK 25 = With Fault 26 = N > Nx and Nt > Nx 27 = Without Error With Delay 28 = No Alarm 29 = Not Used 30 = Redundant Ventilation 31 = Not Used 32 = Circuit Break ON (Input Circuit Breaker ON) 33 = Transference OK 34 = Synchronism OK 35 = Serial 36 = Safety Stop 37 = Sinusoidal Filter Circuit Breaker 38 = Normal/Slave	0	-		11-66

Param.	Description	Adjustable Range	Factory Setting	Unit Setting	Group	Pag.
P282 ⁽¹⁾	Relay Output RL5 Function	0 = Not Used 1 = N* > Nx 2 = N > Nx 3 = N < Ny 4 = N = N* 5 = N = 0 6 = Is > Ix 7 = Is < Ix 8 = Not Used 9 = Not Used 10 = Remote 11 = Run 12 = Ready 13 = No Fault 14 = No E71 + E70 15 = No E22 + E21 + E06 16 = No E62 17 = No E72 18 = (4 to 20) mA OK 19 = Fieldbus 20 = Forward 21 = Process Variable > VPx 22 = Process Variable < VPy 23 = Not Used 24 = Pre-charge OK 25 = With Fault 26 = N > Nx and Nt > Nx 27 = Without Error With Delay 28 = No Alarm 29 = Not Used 30 = Redundant Ventilation Selection 31 = Not Used 32 = Circuit Break ON (Input Circuit Breaker ON) 33 = Transfer OK 34 = Synchronism OK 35 = Serial 36 = Safety Stop 37 = Sinusoidal Filter Circuit Breaker 38 = Normal/Slave	0	-		11-66
P283	Time to RL2 ON	0.0 to 300.0	0.0	s		11-71
P284	Time to RL2 OFF	0.0 to 300.0	0.0	s		11-71
P285	Time to RL3 ON	0.0 to 300.0	0.0	s		11-71
P286	Time to RL3 OFF	0.0 to 300.0	0.0	s		11-71
Nx, Ny, Ix, N = 0, N = N* and Tx						
P288 ⁽²⁾	Nx Speed	0 to P134	120	rpm		11-71
P289 ⁽²⁾	Ny Speed	0 to P134	1800	rpm		11-71
P290 ⁽⁵⁾	Ix Current	0 to 2.0 x P295	1.0 x P295	A		11-71
P291	Speed N = 0	1 to 100	1	%		11-71
P292	Band for N = N*	1 to 100	1	%		11-71
P293	Tx Torque	0 to 200 (P401)	100 (P401)	%		11-71
P294	Overload Class	0 = 115 1 = 150 2 = 100	0	%		11-71

Param.	Description	Adjustable Range		Factory Setting	Unit Setting	Group	Pag.
Inverter Data							
P295 ⁽¹⁾	Inverter Rated Current	G1	G2	According to the rated current of the Inverter	A		11-72
		0 = 32 A	70 = 54 A				
		1 = 53 A	71 = 58 A				
		2 = 70 A	72 = 67 A				
		3 = 80 A	73 = 73 A				
		4 = 85 A	74 = 78 A				
		5 = 94 A	75 = 86 A				
		6 = 100 A	76 = 91 A				
		7 = 110 A	77 = 92 A				
		8 = 112 A	78 = 96 A				
		9 = 120 A	79 = 108 A				
		10 = 130 A	80 = 109 A				
		11 = 138 A	81 = 113 A				
		12 = 140 A	82 = 114 A				
		13 = 150 A	83 = 128 A				
		14 = 160 A	84 = 131 A				
		15 = 162 A	85 = 139 A				
		16 = 165 A	86 = 144 A				
		17 = 170 A	87 = 151 A				
		18 = 175 A	88 = 152 A				
		19 = 186 A	89 = 176 A				
		20 = 188 A	90 = 177 A				
		21 = 210 A	91 = 180 A				
		22 = 235 A	92 = 181 A				
		23 = 250 A	93 = 204 A				
		24 = 265 A	94 = 205 A				
		25 = 280 A	95 = 212 A				
		26 = 300 A	96 = 216 A				
		27 = 310 A	97 = 237 A				
		28 = 357 A	98 = 241 A				
		29 = 375 A	99 = 251 A				
		30 = 386 A	100 = 260 A				
		31 = 450 A	101 = 276 A				
		32 = 475 A	102 = 283 A				
		33 = 490 A	103 = 294 A				
		34 = 500 A	104 = 295 A				
		35 = 560 A	105 = 322 A				
		36 = 580 A	106 = 330 A				
		37 = 1064 A	107 = 332 A				
		38 = 712 A	108 = 348 A				
		39 = 880 A	109 = 376 A				
		40 = 950 A	110 = 390 A				
		41 = 1178 A	111 = 405 A				
		42 = 200 A	112 = 410 A				
		43 = 125 A	113 = 440 A				
		44 = 536 A	114 = 458 A				
		45 = 1072 A	115 = 481 A				
		46 = 1340 A	116 = 494 A				
		47 = 1424 A	117 = 517 A				
		48 = 1760 A	118 = 538 A				
		49 = 1900 A	119 = 561 A				
		50 = 2356 A	120 = 565 A				
		51 = 301 A	121 = 607 A				
			122 = 627 A				
			123 = 631 A				
			124 = 664 A				
			125 = 713 A				
			126 = 740 A				
			127 = 741 A				
			128 = 779 A				
			129 = 816 A				
			130 = 835 A				
			131 = 934 A				
			132 = 941 A				
			133 = 1069 A				
			134 = 1087 A				
			135 = 1234 A				
			136 = 1254 A				
			137 = 1425 A				
			138 = 1482 A				
			139 = 1632 A				
			140 = 1881 A				
			141 = 2138 A				
			142 = 2508 A				
			143 = 2850 A				

Param.	Description	Adjustable Range	Factory Setting	Unit Setting	Group	Pag.
P296 ⁽¹⁾	Inverter Rated Voltage	0 = 220 (Use WEG) 1 = 380 (Use WEG) 2 = 2300 V 3 = 3300 V 4 = 4160 V 5 = 6900 V 6 = 4600 V	According to the voltage supply Inverter	V		11-73
Avoided Speeds						
P303	Skipped Speed 1	P133 to P134	600	rpm		11-73
P304	Skipped Speed 2	P133 to P134	900	rpm		11-73
P305	Skipped Speed 3	P133 to P134	1200	rpm		11-73
P306	Skipped Range	0 to 750	0	rpm		11-73
Serial Communication						
P308 ⁽¹⁾	Serial Address	1 to 30	1	-		11-73
P309 ⁽¹⁾	Fieldbus	0 = Inactive 1 = Profibus DP 2 I/O 2 = Profibus DP 4 I/O 3 = Profibus DP 6 I/O 4 = DeviceNet 2 I/O 5 = DeviceNet 4 I/O 6 = DeviceNet 6 I/O 7 = Modbus-RTU 2 I/O 8 = Modbus-RTU 4 I/O 9 = Modbus-RTU 6 I/O 10 = DeviceNet Drive Profile 11 = Ethernet IP 2 I/O 12 = Ethernet IP 4 I/O 13 = Ethernet IP 6 I/O	0	-		11-74
P312	Type of Serial Protocol	0 = WEG Protocol 1 = Modbus-RTU, 9600 bps, without parity 2 = Modbus-RTU, 9600 bps, odd parity 3 = Modbus-RTU, 9600 bps, even parity 4 = Modbus-RTU, 19200 bps, without parity 5 = Modbus-RTU, 19200 bps, odd parity 6 = Modbus-RTU, 19200 bps, even parity 7 = Modbus-RTU, 38400 bps, without parity 8 = Modbus-RTU, 38400 bps, odd parity 9 = Modbus-RTU, 38400 bps, even parity 10 = WEG Protocol, 19200 bps 11 = WEG Protocol, 38400 bps	0	-		11-74
P313	Disabling with Alarm A128, A129 and A130	0 = Run/Stop 1 = General Enable 2 = Inactive 3 = Go to Local 4 = Not Used 5 = Fatal Failure	0	-		11-75
P314	Time for Serial Watchdog Action	0.0 to 999.0	0.0	s		11-75
P315	MVC3 1 Serial Function	0 = HMI 1 = TECSYSTEM 2 = PEXTRON	0	-		11-75
Flying Start/Ride-Through						
P320 ⁽¹⁾	Flying Start/Ride-Through	0 = Inactive 1 = Flying Start 2 = Flying Start + Ride-Through 3 = Ride-Through	0	-		11-75
P321 ⁽⁴⁾	Ud Line Loss Level	166 to 800 (P296 = 0) 287 to 800 (P296 = 1) 2000 to 8000 (P296 = 2) 2000 to 8000 (P296 = 3) 2000 to 8000 (P296 = 4) 2000 to 8000 (P296 = 5) 2000 to 8000 (P296 = 6)	252 436 2681 3847 4850 4644 5363	V		11-76

Param.	Description	Adjustable Range	Factory Setting	Unit Setting	Group	Pag.
P322 ⁽⁴⁾	Ud Ride-Through	166 to 800 (P296 = 0) 287 to 800 (P296 = 1) 2000 to 8000 (P296 = 2) 2000 to 8000 (P296 = 3) 2000 to 8000 (P296 = 4) 2000 to 8000 (P296 = 5) 2000 to 8000 (P296 = 6)	245 423 2598 3728 4700 4500 5197	V		11-77
P323 ⁽⁴⁾	Ud Line Recovery Level	166 to 800 (P296 = 0) 287 to 800 (P296 = 1) 2000 to 8000 (P296 = 2) 2000 to 8000 (P296 = 3) 2000 to 8000 (P296 = 4) 2000 to 8000 (P296 = 5) 2000 to 8000 (P296 = 6)	267 461 2930 4204 5300 5075 5860	V		11-77
P325	Ride-Through Proportional Gain	0.0 to 63.9	1.0	-		11-78
P326	Ride-Through Integral Gain	0 to 9999	201	-		11-78
P327	Sensorless Flying Start Delay	0.000 to 9.999	0.100	s		11-78
P328	Sensorless Flying Start Frequency	0 = P134 1 = P001	0	-		11-78
P329	Sensorless Flying Start Direction	0 = +P328 1 = -P328 2 = +P328 3 = -P328	0	-		11-78
P331	Voltage Ramp	0.2 to 50.0	8,0	s		11-79
P332	Dead Time	0.1 to 20.0	10.0	s		11-79
P333	Ride-Through Time	0.0 to 20.0	10.0	s		11-79
Motor Parameters P400 to P499						
Nameplate Data						
P400 ^{(1) (4)}	Motor Rated Voltage	0 to 9999	P296	V		11-81
P401 ⁽¹⁾	Motor Rated Current	0.0 to 1.30 x P295	1.0 x P295	A		11-81
P402 ⁽¹⁾	Motor Rated Speed	0 to 7200	1796	rpm		11-81
P403 ⁽¹⁾	Motor Frequency	0 to 120	60	Hz		11-81
P405	Encoder Data	100 to 9999	1024	ppr		11-82
P406 ^{(1) (2)}	Motor Ventilation Type	0 = Self Ventilated 1 = Separate Ventilation	0	-		11-82
Measured Parameters						
P408 ⁽¹⁾	Self-tuning	0 = No Self-tuning 1 = Self-tuning	0	-		11-82
P409 ⁽¹⁾	Motor Stator Resistance (Rs)	0.000 to 9.999	0.000	Ω		11-82
P410	Motor Magnetizing Current (Imr)	0 to 1.25 x P295	0.0	A		11-82
P411 ⁽¹⁾	Motor Flux Leakage Inductance (σls)	0.00 to 99.99	0.00	mH		11-82
P412 ⁽¹⁾	Lr/Rr Constant	0.000 to 9.999	0.000	s		11-82
P413 ⁽¹⁾	TM Constant	0.00 to 99.99	0.00	s		11-82
P414	Magnetizing Voltage	0.0 to 20.0	0.0	%		11-83
P427	LDσ Inductance	0.00 to 99.99	4.85	mH		11-83
P428	LQσ Inductance	0.00 to 99.99	4.41	mH		11-83
P429	RD Resistance	0.000 to 9.999	1.139	Ω		11-84
P430	RQ Resistance	0.000 to 9.999	0.831	Ω		11-84
P431	Number of Motor Poles	2 to 64	4	-		11-84
P433	LQ Inductance	000.0 to 999.9	45.7	mH		11-84
P434	LD Inductance	000.0 to 999.9	86.9	mH		11-84
P436	LF Inductance	000.0 to 999.9	88	mH		11-84
P437	RF Resistance	0.000 to 9.999	0.047	Ω		11-84
P438	Proportional Gain of the Current Regulator IQ	0.000 to 9.999	0.034	-		11-84
P439	Integration Constant of the Current Regulator IQ	0.1 to 999.9	9	-		11-84
P440	Proportional Gain of the Current Regulator ID	0.000 to 9.999	0.074	-		11-84
P441	Integration Constant of the ID Current Regulator	0.1 to 999.9	19.6	-		11-85

Param.	Description	Adjustable Range	Factory Setting	Unit Setting	Group	Pag.
P442	Integration Constant of the Field Current Regulator	0.000 to 9.999	0.788	-		11-85
P443	Integration Constant of the Field Current Regulator	0.1 to 999.9	703	-		11-85
P444	Maximum Field Voltage (Brushless)	0.01 to 1.00	0.58	PU		11-85
P445	Minimum Field Voltage (Brushless)	0.01 to 1.00	0.01	PU		11-85
P446	Base Field Current	0.1 to 999.9	33.3	A		11-85
P447	Proportional Gain of the Field Regulator	0.000 to 9.999	0.087	-		11-85
P448	Integration Constant of the Field Regulator	1 to 9999	70	-		11-85
P449	Maximum Field Current (Brushless)	0.01 to 5.00	0.7	PU		11-85
P450	Minimum Field Current (Brushless)	0.01 to 5.00	0.01	PU		11-85
P451	Minimum Field for Soft-Start Function	0.01 to 5.00	0.15	PU		11-86
P452	Field Input Frequency	0.00 to 10.00	0	Hz		11-86
P453	Field Ramp Time	0.00 to 30.00	1	s		11-86
P454	Polynomial A1 of the Magnetic Saturation Curve	0.000 to 9.999	0.000	-		11-87
P455	Polynomial B1 of the Magnetic Saturation Curve	0.000 to 9.999	0.174	-		11-87
P456	Polynomial C1 of the Magnetic Saturation Curve	0.000 to 9.999	1.059	-		11-87
P457	Polynomial A2 of the Gain Curve of the Brushless Exciter	0.000 to 9.999	0.185	-		11-87
P458	Polynomial B2 of the Gain Curve of the Brushless Exciter	0.000 to 9.999	0.068	-		11-87
P459	Polynomial C2 of the Gain Curve of the Brushless Exciter	0.0 to 999.9	118.7	-		11-88
P460	Field Resistance Not Referred to the Stator	0.001 to 9.999	1.150	Ω		11-88
P461	Rated Current on the Brushless Field	0.1 to 999.9	25.6	A		11-88
P462	Field Current Scale	0.1 to 999.9	94	A		11-88
P463	Exciter Rated Voltage Scale	0 to 9999	380	V		11-88
P464	Maximum Compensation Current of the Power Factor	0.00 to 1.00	0.80	PU		11-88
P465	Field Delay	0.000 to 9.999	0.00	s		11-89
Parameter Graphic HMI						
P490	Graphic HMI LCD Contrast Adjustment	0 to 150	80	%		11-90
P491	Graphic HMI Configuration	0 to 2	0	-		11-90
P493	Sampling Time of the On-line Graphic Function	1 to 100	10	ms		11-90
P500	Read-only Parameter #1 Selection	0 to 9	0	2		11-90
P501	Read-only Parameter #2 Selection	0 to 9	0	0		11-90
P502	Read-only Parameter #3 Selection	0 to 9	0	0		11-90
P503	Read-only Parameter #4 Selection	0 to 9	0	0		11-90
P504	Read-only Parameter #5 Selection	0 to 9	0	0		11-90
P505	Read-only Parameter #6 Selection	0 to 9	0	0		11-90
P512	On-line Graphic Function Parameter #1 Selection	0 to 9	0	2		11-91
P513	On-line Graphic Function Parameter #2 Selection	0 to 9	0	3		11-91
P516	Full Scale of the On-line Graphic Function Parameter #1	0 to 200	100	%		11-91
P517	Full Scale of the On-line Graphic Function Parameter #2	0 to 200	100	%		11-91
Special Functions Parameters P520 to P725						
PID Regulator						
P520	PID Proportional Gain	0.000 to 7.999	1.000	-		11-92
P521	PID Integral Gain	0.000 to 9.999	1.000	-		11-92

Param.	Description	Adjustable Range	Factory Setting	Unit Setting	Group	Pag.
P522	PID Differential Gain	0.000 to 9.999	0.000	-		11-92
P523	PID Ramp Time	0.0 to 999.0	3.0	s		11-92
P524 ^(*)	Selection of the PID Feedback	0 = AI2 1 = AI3	0	-		11-93
P525	PID Setpoint	0.0 to 100.0	0.0	%		11-93
P526	Process Variable Filter	0.0 to 16.0	0.1	s		11-93
P527	PID Action Type	0 = Direct 1 = Reverse	0	-		11-94
P528	Process Variable Scale Factor	0 to 9999	1000	-		11-95
P529	Process Variable Decimal Point	0 to 3	1	-		11-95
P530	Engineering Unite Process Variable 1	32 to 127 (ASCII) A, B, ..., Y, Z 0, 1, ..., 9 #, \$, %, (,), *, +, ...	37 = %	-		11-96
P531	Engineering Unite Process Variable 2	32 to 127 (ASCII) A, B, ..., Y, Z 0, 1, ..., 9 #, \$, %, (,), *, +, ...	32 = blank	-		11-96
P532	Engineering Unite Process Variable 3	32 to 127 (ASCII) A, B, ..., Y, Z 0, 1, ..., 9 #, \$, %, (,), *, +, ...	32 = blank	-		11-96
P533	Value of Process Variable X	0.0 to 100.0	90.0	%		11-96
P534	Value of Process Variable Y	0.0 to 100.0	10.0	%		11-96
P535	Output N = 0 PID	0 to 100	0	%		11-96
Trace Function						
P550	Trigger Parameter	0 to 746	0	-		11-96
P551	Trigger Value	-32768 to +32767	0	-		11-97
P552	Trigger Condition	0 to 20	4	-		11-97
P553	Sampling Time	1 to 9999	1	x500 μs		11-98
P554	Pre - Trigger %	0 to 100	50	%		11-98
P555	CH1	0 to 727	1	-		11-98
P556	CH1 I/O Mask	0 to 16	0	-		11-99
P557	CH2	0 to 727	2	-		11-98
P558	CH2 I/O Mask	0 to 16	0	-		11-99
P559	CH3	0 to 727	3	-		11-98
P560	CH3 I/O Mask	0 to 16	0	-		11-99
P561	CH4	0 to 727	4	-		11-98
P562	CH4 I/O Mask	0 to 16	0	-		11-99
P563	CH5	0 to 727	5	-		11-98
P564	CH5 I/O Mask	0 to 16	0	-		11-99
P565	CH6	0 to 727	6	-		11-98
P566	CH6 I/O Mask	0 to 16	0	-		11-99
P567	CH7	0 to 727	7	-		11-98
P568	CH7 I/O Mask	0 to 16	0	-		11-99
P569	CH8	0 to 727	73	-		11-98
P570	CH8 I/O Mask	0 to 16	0	-		11-99
P571	Trace Activation	0 = Inactive 1 = Active	0	-		11-100
P572	Trace % of Memory	1 to 100	100	%		11-100
P621	Sinusoidal Filter	0 = Inactive 1 = Active 2 = With oversample	0	-		11-101
P622	Boost Final Frequency: I x R	0 to 9999	4095	-		11-101
P629	Synchronism Time OK	1 to 20	1	s		11-101
P630	Synchronism Timeout	20 to 240	60	s		11-101
P631	DI13 Delay	0 to 3000	170	x500μs		11-101

Param.	Description	Adjustable Range	Factory Setting	Unit Setting	Group	Pag.
P632	Maximum Phase Error	0 to 9999	1966	-		11-101
P636	Phase Adjustment	-32768 to 32767	0	-		11-101
P652	Fast Analog Output Function AO1 MVC3	0 to 255	2	-		11-102
P653	Fast Analog Output Gain AO1 MVC3	0 to 9.999	1.000	-		11-103
P654	Fast Analog Output Function AO2 MVC3	0 to 255	5	-		11-103
P655	Fast Analog Output Gain AO2 MVC3	0 to 9.999	1.000	-		11-103
P656	Fast Analog Output Function AO3 MVC3	0 to 255	2	-		11-103
P657	Fast Analog Output Gain AO3 MVC3	0 to 9.999	1.000	-		11-103
P658	Fast Analog Output Function AO4 MVC3	0 to 255	5	-		11-103
P659	Fast Analog Output Gain AO4 MVC3	0 to 9.999	1.000	-		11-103
P663	Fast Analog Output Offset AO1 MVC3	-32768 to 32768	-90	-		11-103
P664	Fast Analog Output Offset AO2 MVC3	-32768 to 32768	-90	-		11-103
P665	Fast Analog Output Offset AO3 MVC3	-32768 to 32768	-90	-		11-103
P666	Fast Analog Output Offset AO4 MVC3	-32768 to 32768	-90	-		11-104
P721 ⁽¹⁾	Input AI5 Function	0 = P221 / P222	0	-		11-104
P722	Input AI5 Gain	0.000 to 9.999	1.000	-		11-104
P723 ⁽¹⁾	Input AI5 Signal	0 = (0 to 10) V / (0 to 20) mA 1 = (4 to 20) mA 2 = (10 to 0) V / (20 to 0) mA 3 = (20 to 4) mA	0	-		11-104
P724	Input AI5 Offset	0.0 to +100.0	0.0	%		11-104
P725	Minimum Coasting Time	0 to 300	0	s		11-104
P727	Parallelism of Inverters	0 = Normal 1 = Parallel 312 2 = Parallel 313 3 = Parallel 314	0	-		11-105
P740	Function of Analog Input AI1 MVC3	0 = Not Used 1 = Torque Reference 2 = Limit Current	0	-		11-105
P741	Analog Input Gain AI1 MVC3	0 to 9.999	1.000	-		11-105
P742	Analog Input Offset AI1 MVC3	-1000 to 1000	0	%		11-105
P743	Modulation Levels	0 = Three level (3L) 1 = Five levels (5L)	0	-		11-105
P744	Function of Analog Input AI2 MVC3	0 = Not Used 1 = Field Current	0	-		11-105
P745	Analog Input Gain AI2 MVC3	0 to 9.999	1.000	-		11-105
P746	Analog Input Offset AI2 MVC3	-1000 to 1000	0	%		11-105
P950	Motor Type	0 = Induction Motor 1 = Synchronous motor with brushes 2 = Brushless synchronous motor	0	-		11-105



NOTE!

Quick parameter reference notes:

- (1) Parameter can be changed only with the inverter disabled (motor stopped).
- (2) Values may change as a function of the motor parameters.
- (3) Values may change as a function of P412.
- (4) Values may change as a function of P296.
- (5) Values may change as a function of P295.
- (6) Values may change as a function of P320.

II. Messages of Alarms and Faults

The faults of the MVW-01 can be subdivided in Alarms (Axxx) and Faults (Fxxx). In general, the alarms serve to indicate a situation that, if it is not corrected, it can carry the inverter to stop by fault. A signaled fault indicates a situation that carried the inverter to be disabled (main breaker opening can or not occur, depending of the type of fault).

Table 1: Alarm and fault messages

Indication (A = Alarm / F = Fault)	Meaning	Page
A001	Mains low voltage	14-1
A002	Mains high voltage	14-1
F003	Mains undervoltage	14-1
F004	Mains overvoltage	14-1
F006	Mains unbalance / loss of phase	14-1
F007	Mains voltage feedback fault	14-1
A008	Line synchronism time-out	14-1
A010	Rectifier high temperature	14-2
F011	Rectifier overtemperature	14-2
F012	Rectifier feedback temperature fault	14-2
F013	Feedback missing on sinusoidal filter	14-2
F014	Input circuit breaker closing failure	14-2
F015	Input circuit breaker opening failure	14-2
F016	External trip by input circuit breaker protection	14-2
F017	Input circuit breaker not ready	14-2
A018	Input transformer alarm	14-2
F019	Input transformer fault	14-2
F020	Pre-charge Fault	14-2
F021	DC link undervoltage	14-2
F022	DC link overvoltage	14-3
F023	DC link imbalance	14-3
F024	Link DC voltage feedback fault	14-3
F025	Door closing fault	14-3
F026	CB not ready	14-3
F030	U 1 IGBT fault	14-3
F031	U 2 IGBT fault	14-3
F032	U 3 IGBT fault	14-3
F033	U 4 IGBT fault	14-3
F034	V 1 IGBT fault	14-3
F035	V 2 IGBT fault	14-3
F036	V 3 IGBT fault	14-3
F037	V 4 IGBT fault	14-3
F038	W 1 IGBT fault	14-3
F039	W 2 IGBT fault	14-3
F040	W 3 IGBT fault	14-3
F041	W 4 IGBT fault	14-3
F042	Braking IGBT 1 fault	14-3
F043	Braking IGBT 2 fault	14-3
F044	Arc detection	14-3
F045	PS1/PS1S power supply fault	14-3
A046	Alarm I x t	14-3
F047	IGBT overload fault	14-3
F048 ⁽⁵⁾	Forced ventilation fault	14-3
A050	U phase heatsink high temperature	14-3
F051	U phase heatsink overtemperature	14-3
F052	U phase heatsink temperature feedback fault	14-4
A053	V phase heatsink high temperature	14-4
F054	V phase heatsink overtemperature	14-4
F055	V phase heatsink temperature feedback fault	14-4
A056	W phase heatsink high temperature	14-4
F057	W phase heatsink overtemperature	14-4
F058	W phase heatsink temperature feedback fault	14-4

Indication (A = Alarm / F = Fault)	Meaning	Page
A059	BR phase heatsink high temperature	14-4
F060	BR phase heatsink overtemperature	14-4
F061	BR phase heatsink temperature feedback fault	14-4
F062	Thermal imbalance between phases U, V and W	14-4
F063	U output voltage feedback fault	14-4
F064	V output voltage feedback fault	14-4
F065	W output voltage feedback fault	14-4
F066	Null current	14-4
F068	Failure when entering in test mode	14-4
F069	Calibration fault	14-4
F070	Overcurrent / short circuit	14-5
F071	Overcurrent at output	14-5
F072 ⁽⁵⁾	Overload I x t	14-5
A073	Fault to ground alarm	14-5
F074	Ground fault	14-5
F075	Failure feedback of voltage between the Medium Point (MP) DC Link and ground	14-5
F076	Motor connection open / Motor unbalanced current	14-5
F077	Braking resistor overload	14-5
F078 ⁽⁵⁾	Motor overtemperature	14-5
F079 ⁽⁵⁾	Encoder fault	14-5
F080	CPU (watchdog) fault	14-6
F081	Program memory fault	14-6
F082 ⁽⁵⁾	Copy function fault	14-6
F083 ⁽⁵⁾	Programming fault	14-6
F084	Auto-Diagnosis fault	14-6
F085	Electronic power supply fault	14-6
F087	Control boards communication fault	14-6
F090 ⁽⁵⁾	External defect (MVC4) fault	14-6
F092	Pre-charge supply fault	14-6
A093	Rectifier redundant ventilation failure alarm - set A	14-6
A094	Inverter redundant ventilation failure alarm - set A	14-6
F095	PS1 supply fault	14-6
A096	Alarm 4 to 20 mA (current <3 mA)	14-6
F097 ⁽⁵⁾	Fault 4 to 20 mA	14-6
A098	Not recorded help/Incompatible graphic HMI version	14-6
F099	Invalid current offset	14-6
F100	MVC3 fatal fault	14-6
F101 ⁽⁵⁾	Incompatible software version between boards	14-6
F102	Unknown failure in EPLD of MVC3	14-6
F103	MVC3 RAM fault	14-6
F104	MVC3 A/D failure	14-6
F105	EEPROM of MVC3 fault	14-6
F106	MVC4 fatal fault	14-6
A107	Alarm for WEG use	14-6
A108	Not initialized inverter alarm	14-6
F109	MVC3 external general disable fault	14-7
A110	Motor overtemperature alarm	14-7
A111	External defect alarm	14-7
F112	Motor overspeed fault	14-7
A113	Rectifier redundant ventilation failure alarm - set B	14-7
A114	Inverter redundant ventilation failure alarm - set B	14-7
F115	Communication fault between master rack and slave rack	14-7
F116	Slave under fault condition	14-7
F117	Current unbalance between slave drives	14-7
A123	Programming Alarm	14-7
A124	Parameter alteration with enabled inverter	14-7
A125	Reading / writing in inexistent parameter	14-7
A126	Value out of range	14-7
A127	Function not configured for Fieldbus	14-7
A129	Inactive Fieldbus connection	14-7
A130	Inactive Fieldbus board	14-7

Indication (A = Alarm / F = Fault)	Meaning	Page
A131 ⁽¹⁾	Rectifier 1p high temperature	14-7
F132 ⁽¹⁾	Rectifier 1p overtemperature	14-7
F133 ⁽¹⁾	Rectifier 1p temperature feedback fault	14-7
F134 ⁽¹⁾	UAp 1 IGBT fault	14-8
F135 ⁽¹⁾	UAp 2 IGBT fault	14-8
F136 ⁽¹⁾	UAp 3 IGBT fault	14-8
F137 ⁽¹⁾	UAp 4 IGBT fault	14-8
F138 ⁽¹⁾	VAp 1 IGBT fault	14-8
F139 ⁽¹⁾	VAp 2 IGBT fault	14-8
F140 ⁽¹⁾	VAp 3 IGBT fault	14-8
F141 ⁽¹⁾	VAp 4 IGBT fault	14-8
F142 ⁽¹⁾	WAp 1 IGBT fault	14-8
F143 ⁽¹⁾	WAp 2 IGBT fault	14-8
F144 ⁽¹⁾	WAp 3 IGBT fault	14-8
F145 ⁽¹⁾	WAp 4 IGBT fault	14-8
F148 ^{(1) (4)}	PS1 2 power supply fault	14-8
A149 ⁽¹⁾	UAp phase heatsink high temperature	14-8
F150 ⁽¹⁾	UAp phase heatsink overtemperature	14-8
F151 ⁽¹⁾	UAp phase heatsink temperature feedback fault	14-8
A152 ⁽¹⁾	VAp phase heatsink high temperature	14-8
F153 ⁽¹⁾	VAp phase heatsink overtemperature	14-8
F154 ⁽¹⁾	VAp phase heatsink temperature feedback fault	14-8
A155 ⁽¹⁾	WAp phase heatsink high temperature	14-8
F156 ⁽¹⁾	WAp phase heatsink overtemperature	14-8
F157 ⁽¹⁾	WAp phase heatsink temperature feedback fault	14-8
A158 ⁽¹⁾	BR B heatsink high temperature	14-9
F159 ⁽¹⁾	BR B heatsink overtemperature	14-9
F160 ⁽¹⁾	BR B heatsink temperature feedback fault	14-9
F161 ⁽¹⁾	Thermal imbalance between UAp, VAp and WAp phases	14-9
F162 ⁽¹⁾	UAp output voltage feedback fault	14-9
F163 ⁽¹⁾	VAp output voltage feedback fault	14-9
F164 ⁽¹⁾	WAp output voltage feedback fault	14-9
A165	Safety Stop Active	14-9
F166 ⁽²⁾	Thermal imbalance among the UB, VB and WB phase heatsinks	14-9
F167 ⁽³⁾	Thermal imbalance among the UBp, VBp and WBp phase heatsinks	14-9
F168	Rectifier 123 thermal imbalance	14-9
F169	Rectifier 123p thermal imbalance	14-9
A170	Rectifier 2 high temperature	14-9
F171 ⁽⁴⁾	Rectifier 2 overtemperature	14-9
F172	Rectifier 2 temperature feedback fault	14-9
A173 ⁽⁴⁾	Rectifier 3 high temperature	14-10
F174 ⁽⁴⁾	Rectifier 3 overtemperature	14-10
F175 ⁽⁴⁾	Rectifier 3 temperature feedback fault	14-10
F176 ⁽²⁾	IGBT UB 1 fault	14-10
F177 ⁽²⁾	IGBT UB 2 fault	14-10
F178 ⁽²⁾	IGBT UB 3 fault	14-10
F179 ⁽²⁾	IGBT UB 4 fault	14-10
F180 ⁽²⁾	IGBT VB 1 fault	14-10
F181 ⁽²⁾	IGBT VB 2 fault	14-10
F182 ⁽²⁾	IGBT VB 3 fault	14-10
F183 ⁽²⁾	IGBT VB 4 fault	14-10
F184 ⁽²⁾	IGBT WB 1 fault	14-10
F185 ⁽²⁾	IGBT WB 2 fault	14-10
F186 ⁽²⁾	IGBT WB 3 fault	14-10
F187 ⁽²⁾	IGBT WB 4 fault	14-10
F188 ⁽⁴⁾	PS1 3 power supply fault	14-10
A189 ⁽²⁾	UB phase heatsink high temperature	14-10
F190 ⁽²⁾	UB phase heatsink overtemperature	14-10
F191 ⁽²⁾	UB phase heatsink temperature feedback fault	14-10
A192 ⁽²⁾	VB phase heatsink high temperature	14-10

Indication (A = Alarm / F = Fault)	Meaning	Page
F193 ⁽²⁾	VB phase heatsink overtemperature	14-10
F194 ⁽²⁾	VB phase heatsink temperature feedback fault	14-10
A195 ⁽²⁾	WB phase heatsink high temperature	14-10
F196 ⁽²⁾	WB phase heatsink overtemperature	14-11
F197 ⁽¹⁾	WB phase heatsink temperature feedback fault	14-11
F198 ⁽²⁾	UB phase output voltage feedback fault	14-11
F199 ⁽²⁾	VB phase output voltage feedback fault	14-11
F200 ⁽²⁾	WB phase output voltage feedback fault	14-11
F210 ⁽³⁾	IGBT UBp 1 fault	14-11
F211 ⁽³⁾	IGBT UBp 2 fault	14-11
F212 ⁽³⁾	IGBT UBp 3 fault	14-11
F213 ⁽³⁾	IGBT UBp 4 fault	14-11
F214 ⁽³⁾	IGBT VBp 1 fault	14-11
F215 ⁽³⁾	IGBT VBp 2 fault	14-11
F216 ⁽³⁾	IGBT VBp 3 fault	14-11
F217 ⁽³⁾	IGBT VBp 4 fault	14-11
F218 ⁽³⁾	IGBT WBp 1 fault	14-11
F219 ⁽³⁾	IGBT WBp 2 fault	14-11
F220 ⁽³⁾	IGBT WBp 3 fault	14-11
F221 ⁽³⁾	IGBT WBp 4 fault	14-11
F222 ⁽³⁾	PS1 4 power supply fault	14-11
A223 ⁽³⁾	UBp phase heatsink high temperature	14-11
F224 ⁽³⁾	UBp phase heatsink overtemperature	14-11
F225 ⁽³⁾	UBp phase heatsink temperature feedback fault	14-11
A226 ⁽³⁾	VBp phase heatsink high temperature	14-11
F227 ⁽³⁾	VBp phase heatsink overtemperature	14-11
F228 ⁽³⁾	VBp phase heatsink temperature feedback fault	14-11
A229 ⁽³⁾	WBp phase heatsink high temperature	14-11
F230 ⁽³⁾	WBp phase heatsink overtemperature	14-12
F231 ⁽³⁾	WBp phase heatsink temperature feedback fault	14-12
F232 ⁽³⁾	UBp phase output voltage feedback fault	14-12
F233 ⁽³⁾	VBp phase output voltage feedback fault	14-12
F234 ⁽³⁾	WBp phase output voltage feedback fault	14-12
F236 ⁽⁴⁾	V DC link imbalance	14-12
F237 ⁽⁴⁾	W DC link imbalance	14-12
F238 ⁽⁴⁾	V DC link overvoltage (Positive or Negative)	14-12
F239 ⁽⁴⁾	W DC link overvoltage (Positive or Negative)	14-12

Notes:

- (1) Only frame size C, D and E models.
- (2) Only frame size D and E models.
- (3) Only frame size E models.
- (4) Only frame size C1, C2 and C3 models.
- (5) It does not open the circuit breaker.

1 SAFETY NOTICES

This manual contains the necessary information for the correct use of the MVW-01 Frequency Inverter.

It has been written for qualified personnel with suitable training or technical qualifications to operate this type of equipment.

This manual presents all the functions and parameters of the MVW-01, but does not aim to present all the possible MVW-01 applications. WEG is not liable for applications not described in this manual.

This product is not intended for applications whose function is to ensure the physical integrity and/or the life of people, or any other application where failure of the MVW-01 can create a risk to the physical integrity and/or life of people. The designer who applies the MVW-01 must provide ways to ensure the safety of the installation even in the event of a drive failure.

1.1 SAFETY NOTICES IN THE MANUAL

Throughout this manual the following safety notes are used:



DANGER!

The procedures recommended in this warning have the purpose of protecting the user against dead, serious injuries and considerable material damage.



DANGER!

Les procédures concernées par cet avertissement sont destinées à protéger l'utilisateur contre des dangers mortels, des blessures et des détériorations matérielles importantes.



ATTENTION!

The procedures recommended in this warning have the purpose of avoiding material damage.



NOTE!

The text intends to supply important information for the correct understanding and good operation of the product.

1.2 SAFETY NOTICES ON THE PRODUCT

The following symbols are attached to the product, serving as safety notices:



High voltages are present.



Components sensitive to electrostatic discharge.
Do not touch them.



Mandatory connection to the protective ground (PE).



Connection of the shield to the ground.



Hot surface.

1.3 MVW-01 IDENTIFICATION LABEL

The MVW-01 identification label is positioned in the inner part of the Control Panel of the product. This label describes important information about the inverter.

1

UNIDADE AUTOMAÇÃO SWITCHGEAR AND CONTROLGEAR	
TYPE : MVW-01 YEAR OF MANUFACTURE: DOCUMENT: 10002984850 SERIAL #: PART NUMBER: 12878926 WEIGHT: 1560 kg IP: 41	Ur: 7,2 kV fr: 50 Hz Up: 45 kV Ud: 15 kV Ua COMMAND: 24 Vdc / 220 Vac Ir (Bus bar): 330 A Ik: 6 kA Ip: 15,6 kA
INSTRUCTIONS MANUAL: 0899.5247	

Figure 1.1: MVW-01 identification label (example)

1.4 PRELIMINARY RECOMMENDATIONS



DANGER!

Only qualified personnel familiar with the MVW-01 frequency inverter and associated equipment should plan or implement the installation, start-up and subsequent maintenance of this equipment. These personnel must follow all the safety instructions included in this manual and/or defined by local regulations. Failure to comply with these instructions can lead to death, serious injuries or considerable material damage.



DANGER!

Seul le personnel qualifié et familier avec l'onduleur de fréquence MVW-01 et ses équipements associés doit préparer et mettre en oeuvre l'installation, démarrer et ensuite entretenir cet équipement. Ce personnel doit suivre toutes les instructions de sécurité comprises dans ce mode d'emploi et/ou définies par la réglementation locale. Le non respect de ces instructions peut causer la mort, des blessures graves ou d'importants dégâts matériels.



NOTE!

For the purposes of this manual, qualified personnel are those trained to be able to:

1. Install, ground, energize and operate the MVW-01 according to this manual and the effective legal safety procedures.
2. Use the protection equipments according to the established standards.
3. Give first aid services.



DANGER!

Always disconnect the input power before touching any electrical component associated to the inverter. Many components can remain charged with high voltages or remain in movement (fans) even after that AC power is disconnected or switched off. Wait at least 10 minutes to assure a total discharge of the capacitors. Always connect the equipment frame to the protection earth (PE) at the suitable connection point.

**DANGER!**

Débranchez toujours l'alimentation générale avant de toucher un composant électrique associé au convertisseur. Nombreux composants peuvent rester chargés avec haute tension et/ou en mouvement (ventilateurs), même après que l'entrée d'alimentation CA a été débranchée ou coupée. Attendez au moins 10 minutes pour s'assurer de la décharge totale des condensateurs. Connectez toujours le boîtier de l'équipement à terre de protection (PE) au point adéquat pour ça.

**ATTENTION!**

Electronic boards have components sensitive to electrostatic discharges. Do not touch directly on components or connectors. If necessary, touch the grounded metallic frame before or use an adequate grounded wrist strap.

**Do not perform any high pot tests with the inverter!
If it is necessary consult WEG.**

**NOTE!**

Frequency inverter may interfere with other electronic equipment. In order to reduce these effects, take the precautions recommended.

**NOTE!**

Read the user's manual completely before installing or operating the inverter.

2 GENERAL INFORMATION

This chapter defines the contents and the purpose of this manual and describes the main characteristics of the MVW-01 frequency inverter and how to identify its components. It provides also additional information on the receiving and storage of the product.

2.1 ABOUT THIS MANUAL

This manual presents 14 chapters, which have a logical sequence so that the user receives, installs, programs and operates the MVW01:

- Chapter 1 SAFETY NOTICES on page 1-1.
- Chapter 2 GENERAL INFORMATION on page 2-1.
- Chapter 3 MVW-01 WITH 3 LEVELS (3L) on page 3-1.
- Chapter 4 MVW-01 WITH 5 LEVELS (5L) on page 4-1.
- Chapter 5 MVW-01C (COMPACT) on page 5-1.
- Chapter 6 INVERTER PARALLELISM on page 6-1.
- Chapter 7 SYNCHRONOUS MOTOR LINE on page 7-1.
- Chapter 8 INSTALLATION, CONNECTION AND ENERGIZATION on page 8-1.
- Chapter 9 KEYPAD (HMI) OPERATION on page 9-1.
- Chapter 10 OPTIONAL ACCESSORIES AND BOARDS on page 10-1.
- Chapter 11 DETAILED PARAMETER DESCRIPTION on page 11-1.
- Chapter 12 SPECIAL FUNCTIONS on page 12-1.
- Chapter 13 COMMUNICATION NETWORKS on page 13-1.
- Chapter 14 DIAGNOSTICS AND TROUBLESHOOTING on page 14-1.

This user's manual contains information about WEG MVW-01 Medium Voltage Inverter. This document is arranged in dedicated and specific chapters to explain the proper handling, installation, parameterization, care, troubleshooting, adaption to applications and functionalities of the equipment.

The characteristics and recommendations contained in this manual were based on models of the standard MVW-01. It is worth of notice that, in addition to supplying standard products, WEG technical team composed of distinct departments (Technical Sales, Contract Management, Engineering, Technical Assistance, among others) is qualified to develop and provide customized solutions according to the needs of its customers and specific applications.

The MVW-01 product can be customized (engineered) to meet the needs and technical specifications of our customers. Variations in sizes, technical recommendations, performance data and necessity to add optional items are possible in relation to the information contained in this document.

Besides the user's manual, the Supply Project is part of the documentation delivered to the customer. This project contains all the electrical, mechanical and parameterization information, as well as instructions for the interface/installation with other equipment regarding the MVW-01 supplied.

The MVW-01, as well as other WEG products, is in constant evolution in relation to both its internal parts (hardware) and its programming (software/firmware). Any question about the equipment and its documentation can be answered by means of WEG communication channels.

WEG is not liable for the improper use of the information contained in this manual.

2.2 SOFTWARE VERSION

It is important to note the software version installed in the MVW-01, since it defines the functions and the programming parameters of the inverter. This manual refers to the firmware version as stated in the inside cover. For instance, the version 3.2X means from 3.20 to 3.29, where "X" are evolutions in the firmware that do not affect the contents of this manual.

In the version 3.2X, the new control boards MVC4 and Graphic HMI 2 (HMIG2) have exactly the same functions of the MVC2 boards and conventional Graphic HMI in the 1.9X version; therefore, there are no additional remarks about these boards.

2.3 HOW TO SPECIFY THE MVW-01 MODEL

2

POWER SUPPLY	Voltage	■ 2300, 3300, 4160 V, 4600 or 6900 V ($\pm 10\%$, -20% with output power reduction).	
	Frequency	■ 50 or 60 Hz (specify) $\pm 3\%$.	
	Voltage imbalance between phases	■ $<3\%$.	
	Cos φ	■ >0.97 .	
	Overvoltage category	■ Category III.	
AUXILIARY SUPPLY	Voltage	■ 220, 380, 400, 415, 440, 460 or 480 V.	
	Frequency	■ 50 or 60 Hz ($\pm 3\%$).	
	Voltage imbalance between phase	■ $<3\%$.	
PROTECTION DEGREE	Standard	■ IP41.	
DIMENSION	Width / Height / Depth (mm)	■ 8 distinct frame sizes.	
ENVIRONMENTAL CONDITIONS	Temperature	■ 0 to 40 °C (up to 50 °C with 2.5 % reduction in the output current/ °C).	
	Humidity	■ 5 to 90 % without condensation.	
	Altitude	■ 0 to 1000 m (up to 4000 m with 10 % reduction in the output current / 1000 m).	
	Pollution degree	■ 2.	
FINISHING	Color	■ Gray ultra dull (Doors).	
		■ Blue ultra dull (Base, Roof, Shutters).	
CONTROL	Microprocessor	■ 32 bits.	
	Control method	■ Sinusoidal PWM with Space Vector Modulation (SVM) and Optimized Pulse Patterns (OPP) Digital.	
	Control types	■ Scalar (Imposed Voltage - V/F), Vector (encoder and sensorless).	
	Switching	■ High voltage IGBT transistor IGBT (HV - IGBT).	
	Frequency range	■ 0 to 120 Hz.	
	Allowed overload	■ 150 % during 60 seconds, every 10 minutes (1.5 x Inom. - HD). ■ 115 % during 60 seconds, every 10 minutes (1.15 x Inom. - ND).	
	Efficiency	■ Higher 98.5 %.	
PERFORMANCE	Speed control	V/F	■ Regulation 1 % of the nominal speed with slip compensation. ■ Resolution: 1 rpm (keypad reference).
		Sensorless	■ Regulation: 0.5 % of the nominal speed. ■ Speed variation range: 1:100.
		With Encoder (using EBA or EBB board)	■ Regulation: ■ $\pm 0.01\%$ of the nominal speed with a 14-bit analog input (EBA). ■ $\pm 0.01\%$ of the nominal speed with digital reference (keypad, Serial, Fieldbus, Electronic Potentiometer, Multispeed). ■ $\pm 0.1\%$ of nominal speed with 10-bit analog input (CC9).
INPUTS OUTPUTS	Analogical	<ul style="list-style-type: none"> ■ 2 programmable differential inputs (10 bits): 0 to 10 V, 0 to 20 mA or 4 to 20 mA. ■ 1 programmable bipolar input (14 bits): -10 to +10 V, 0 to 20 mA or 4 to 20 mA. ■ 1 programmable isolated input (10 bits): 0 to 10 V, 0 to 20 mA or 4 to 20 mA. ■ 1 programmable isolated input (10 bits): 0 to 10 V, 0 to 20 mA or 4 to 20 mA. ■ 2 programmable outputs (11 bits): 0 to 10 V. ■ 2 bipolar programmable outputs (14 bits): (-10 to +10) V. ■ 2 programmable isolated outputs (11 bits): 0 to 20 mA or 4 to 20 mA. ■ 2 programmable isolated outputs (11 bits): 0 to 20 mA or 4 to 20 mA. 	
	Digital Analog Relay Transistor	<ul style="list-style-type: none"> ■ 8 programmable isolated inputs: 24 Vdc. ■ 1 programmable isolated input: 24 Vdc. ■ 1 programmable isolated input: 24 Vdc (for motor PTC thermistor). ■ 5 programmable outputs, contacts NO/NC: 240 Vac, 1 A. ■ 2 programmable isolated open collector outputs: 24 Vdc, 50 mA. 	
COMMUNICATION	Serial Interface Fieldbus Networks	■ RS-232 (point to point).	
		■ RS-485, isolated, via EBA or EBB board (multipoint up to 30 inverters).	
		■ Modbus RTU (incorporated software) via RS-485 serial interface.	
		■ Profibus DP or DeviceNet via additional KFB kits.	
		■ Ethernet.	

SAFETY	Protections (memory of the last 100 faults/alarms with date and time)	■ DC link overvoltage.	■ Short-circuit at the output.
		■ DC link undervoltage.	■ Phase-ground short-circuit at the output.
		■ Overtemperature at the inverter and at the motor.	■ External fault.
		■ Overcurrent at the output.	■ Auto-diagnosis fault and programming error.
		■ Motor overload (I x t).	■ Serial communication fault.
		■ Braking resistor overload.	■ Phase loss at the input.
		■ CPU (watchdog)/EEPROM fault.	■ HMI-MVW-01 interface connection fault.
		■ Incremental encoder fault.	
APPLICABLE STANDARDS	Electromagnetic compatibility	■ EMC directive 89 / 336 / EEC – industrial environment. ■ EN 61800-3 (EMC - Emission and Immunity) standard.	
	CEI - IEC 61800	■ Adjustable Speed Electrical Power Drive System.	
		■ Part 4 - General Requirements.	
		■ Part 5 - Safety Requirements.	
HUMAN MACHINE INTERFACE (LCD DISPLAY)	Command	■ Start/Stop, Parameterization (Programming of general functions).	
		■ Increase/decrease the speed.	
		■ JOG, Forward/Reverse selection, Local/Remote selection.	
	Supervision (Reading)	■ Speed reference (rpm).	
		■ Motor speed (rpm).	
		■ Value proportional to the speed (e.g.: m/min).	
		■ Motor frequency (Hz).	
		■ TDC link voltage (V).	
		■ Motor torque %.	
		■ Output power (kW).	
		■ Energized time (h).	
		■ Operation time (h).	
		■ Motor current (A).	
		■ Motor voltage (V).	
		■ Inverter status.	
		■ Digital input status.	
		■ Digital output (transistor) status.	
		■ Relay output status.	
		■ Analog input values.	
		■ 100 last errors in the memory with date and time.	
■ Fault/alarm messages.			
AVAILABLE RESOURCES/ FUNCTIONS	Options	■ Blank cover for local HMI.	
		■ Blank cover for remote HMI.	
		■ Frame kit for remote interface.	
		■ Frame kit for remote interface.	
		■ Fieldbus network communication kits (internal inverter installation).	■ Profibus DP.
		■ Fieldbus network communication kits (internal inverter installation).	■ DeviceNet.
		■ SuperDrive kit with RS-232 serial communication interface (Inverter - PC).	
		■ Ethernet kit.	
■ I/O expansion kit.			

2.3.1 Available Models

Nowadays, the MVW-01 medium voltage inverter line can be divided in 2 distinct generations, G1 and G2. The second generation (G2) is based in the use of semiconductor devices with higher current capacity and efficiency, besides an improvement in the inverter cooling system. These combined features resulted in the increase of the power density of the inverters, now named MVW-01 G2.

The next tables present the available models for both generations, and in the same generation the models are subdivided by their topology of 3 levels (3L) or 5 levels (5L).

Table 2.1: G1 - 3 level models

Nominal Voltage [V]	Heavy Duty - HD ⁽¹⁾				Normal Duty - ND ⁽¹⁾				Frame Size
	Rated Output Current [A]	Rated Output Current		Nominal Power Losses [kW]	Rated Output Current [A]	Applicable Motor Power		Nominal Power Losses [kW]	
		[HP]	[kW]			[HP]	[kW]		
2300	85	380	280	3.54	97	430	320	4.10	A0
	100	440	330	4.24	112	500	370	4.82	
	112	490	373	4.82	125	550	420	5.49	
	125	550	416	5.49	138	600	450	6.17	
	120	500	400	4.35	137	600	450	4.69	A
	140	600	450	4.69	160	700	500	5.14	
	165	700	500	5.14	175	750	560	5.32	
	175	750	560	5.32	200	900	710	6.00	
	210	900	710	6.00	240	1000	750	6.82	
	250	1000	800	6.82	280	1250	900	7.47	
	280	1250	900	7.47	320	1500	1120	8.85	B
	386	1750	1250	10.80	440	2000	1400	12.65	
	450	2000	1400	12.65	490	2250	1600	13.89	
	490	2250	1600	13.89	560	2500	1800	16.19	
	560	2500	1800	16.19	640	3000	2200	19.45	C
	730	3250	2400	21.10	835	3700	2800	25.37	
	855	3800	2850	24.72	930	4150	3100	28.25	
	930	4150	3100	26.88	1064	4750	3550	32.33	
1064	4750	3550	30.76	1216	5400	4050	36.95		
1064	4750	3550	30.76	1216	5400	4050	36.95		
3300	85	500	400	4.71	97	600	450	5.14	A0
	100	600	450	5.14	112	700	500	5.51	
	112	700	500	5.51	128	800	630	6.36	
	125	750	560	5.95	138	850	670	6.61	
	138	800	630	6.36	150	900	710	6.78	A
	150	900	710	6.78	160	1000	800	7.15	
	160	1000	800	7.15	182	1250	900	8.15	
	186	1250	900	8.15	212	1500	1120	10.26	
	235	1500	1120	10.26	265	1750	1250	11.68	
	265	1750	1250	11.68	302	2000	1400	14.01	
	310	2000	1400	14.01	354	2250	1600	17.16	C
	375	2500	1800	16.68	428	2750	2000	19.17	
	500	3000	2200	22.37	571	3750	2800	26.05	
	580	3750	2800	26.05	650	4000	3000	29.29	
	670	4200	3150	33.29	755	4500	3550	39.93	D
880	5500	4100	39.93	1008	6000	4500	48.91	E	
1178	7000	5225	53.24	1235	8000	6000	65.21	E	
4160	70	500	400	5.14	80	600	450	5.43	A0
	80	600	450	5.43	91	700	500	5.85	
	94	700	500	5.85	110	800	630	6.38	
	110	800	630	6.38	120	900	710	6.72	
	120	900	710	6.72	130	1000	800	7.07	
	130	1000	800	7.07	148	1250	900	8.21	A
	162	1250	900	8.29	170	1350	1000	8.62	
	170	1350	1000	8.62	188	1500	1120	9.38	
	188	1500	1120	9.38	214	1750	1300	12.07	
	250	2000	1400	12.31	286	2250	1600	14.23	
	300	2250	1600	14.31	342	2750	2000	17.07	
	357	3000	2200	17.07	408	3500	2600	21.60	C
	475	4000	2900	22.83	542	4500	3300	26.22	D
	536	4200	3150	26.74	610	4500	3550	34.41	
	712	5500	4100	35.08	815	6000	4500	40.55	
950	7000	5225	46.78	1086	8000	6000	54.08		

(1) Overload capacity:
 ND: Normal Duty: 115 % overload during 60 seconds every 10 minutes.
 HD: Heavy Duty: 150 % overload during 60 seconds every 10 minutes.

Table 2.2: G1 - 5 level models

Nominal Voltage [V]	Heavy Duty - HD ⁽¹⁾				Normal Duty - ND ⁽¹⁾				Frame Size
	Rated Output Current [A]	Applicable Motor Power		Nominal Power Losses [kW]	Rated Output Current [A]	Applicable Motor Power		Nominal Power Losses [kW]	
		[HP]	[kW]	[HP]		[kW]			
6000~6300	44	420	320	8.12	58	500	373	9.44	C1
	59	500	373	9.54	78	750	560	11.44	
	79	750	560	11.55	104	1000	750	14.23	
	95	900	680	13.24	124	1500	1120	16.52	
	107	1000	750	14.57	140	1750	1300	18.45	
6600~6900	40	420	320	8.11	53	500	373	9.36	C1
	53	500	373	9.36	70	750	560	11.08	
	72	750	560	11.29	94	1000	750	13.67	
	85	900	680	12.68	112	1500	1120	15.73	
	99	1000	750	14.23	130	1750	1300	17.89	

(1) Overload capacity:

ND: Normal Duty: 115 % overload during 60 seconds every 10 minutes.

HD: Heavy Duty: 150 % overload during 60 seconds every 10 minutes.

Table 2.3: G2 - 3 level models

Nominal Voltage [V]	Heavy Duty - HD ⁽¹⁾				Normal Duty - ND ⁽¹⁾				Maximum Current - MX ⁽¹⁾				Frame Size
	Rated Output Current [A]	Applicable Motor Power		Nominal Power Losses [kW]	Rated Output Current [A]	Applicable Motor Power		Nominal Power Losses [kW]	Rated Output Current [A]	Applicable Motor Power		Nominal Power Losses [kW]	
		[HP]	[kW]			[HP]	[kW]			[HP]	[kW]		
3300	85	500	400	4.38	96	600	450	4.86	98	600	450	4.95	A0
	99	600	450	4.99	113	700	500	5.61	116	700	500	5.75	
	115	750	560	5.70	131	800	630	6.44	134	800	630	6.58	
	134	800	630	6.58	152	900	710	7.45	155	900	710	7.55	
	155	900	710	7.60	176	1100	850	8.65	180	1100	850	8.86	
	180	1100	800	7.23	204	1250	1000	8.05	214	1250	1000	8.40	
	208	1350	1000	8.19	237	1500	1100	9.23	249	1500	1100	9.67	A
	242	1500	1120	9.41	276	1750	1250	10.69	290	1750	1250	11.23	
	280	2000	1400	10.85	322	2250	1600	12.51	338	2250	1600	13.16	
	325	2250	1600	12.63	376	2500	1800	14.77	395	2500	1800	15.60	
	382	2600	1900	16.64	440	3000	2200	18.67	463	3000	2200	19.50	C
	448	3000	2200	18.96	517	3500	2500	21.49	544	3500	2500	22.51	
	526	3600	2600	21.83	607	3850	3000	24.96	639	3850	3000	26.24	
	618	4000	3000	25.40	713	4500	3550	29.30	751	4500	3550	30.92	D
	707	4500	3500	30.18	816	5000	4000	34.43	859	5000	4000	36.69	
	809	5000	4000	34.14	934	6000	4500	39.26	984	6000	4500	41.39	
	926	6000	4500	38.93	1069	7250	5600	45.11	1126	7250	5600	47.68	E
	1070	7250	5300	44.34	1234	8000	6300	50.79	1300	8000	6300	53.38	
1235	8000	6000	50.76	1425	9000	7100	58.55	1501	9000	7100	61.79		
1414	9000	7100	60.36	1632	10000	8000	68.85	1718	10000	8000	73.38	2xD	
1852	12000	9000	77.86	2138	12500	10000	90.22	2252	12500	10000	95.35		
2470	16000	12000	101.52	2850	17500	14000	117.11	3002	17500	14000	123.58	2xE	
4160	70	550	400	4.60	78	600	450	4.97	85	600	450	5.29	A0
	83	650	500	5.20	92	700	560	5.63	101	700	560	6.06	
	98	750	600	5.92	108	850	630	6.41	118	850	630	6.91	
	115	900	630	6.76	128	1000	710	7.42	140	1000	710	8.04	
	135	1100	800	7.78	151	1200	900	8.63	165	1200	900	9.38	
	162	1300	1000	8.78	181	1500	1100	9.67	195	1500	1100	10.33	
	195	1600	1100	10.33	216	1700	1250	11.34	233	1700	1250	12.18	A
	235	1900	1400	12.28	260	2200	1600	13.53	280	2200	1600	14.57	
	265	2200	1600	13.98	294	2500	1800	15.39	312	2500	1800	16.28	
	300	2500	1900	15.69	330	2700	2000	17.18	350	2700	2000	18.20	
	365	3000	2250	20.91	405	3500	2500	22.81	436	3500	2500	24.31	C
	447	3700	2800	24.85	494	4000	3000	27.19	532	4000	3000	29.12	
	506	4000	3150	28.26	561	4500	3500	30.90	595	4500	3500	32.56	
	570	4500	3550	31.33	627	5000	4000	34.14	665	5000	4000	36.05	D
	670	5500	4250	37.67	741	6500	4750	41.31	798	6500	4750	44.30	
	757	6500	4750	42.84	835	7250	5500	46.72	885	7250	5500	49.25	
	855	7250	5500	47.73	941	7750	6000	52.13	998	7750	6000	55.11	E
	988	7750	6000	55.37	1087	8500	7000	60.10	1153	8500	7000	63.30	
1140	9000	7100	62.67	1254	10000	8000	68.28	1330	10000	8000	72.09		
1340	11000	8500	75.35	1482	12500	9500	82.62	1596	12500	9500	88.61	2xD	
1710	14000	11000	95.46	1881	16000	12000	104.27	1995	16000	12000	110.23		
2280	20000	14000	125.34	2508	22500	16000	136.57	2660	22500	16000	144.19	2xE	

(1) Overload capacity:
 MX: Maximum Current: overload is not allowed.
 ND: Normal Duty: 115 % overload during 60 seconds every 10 minutes.
 HD: Heavy Duty: 150 % overload during 60 seconds every 10 minutes.

Table 2.4: G2 – 5 level models

Nominal Voltage [V]	Heavy Duty - HD ⁽¹⁾				Normal Duty - ND ⁽¹⁾				Maximum Current - MX ⁽¹⁾				Frame Size
	Rated Output Current [A]	Applicable Motor Power		Nominal Power Losses [kW]	Rated Output Current [A]	Applicable Motor Power		Nominal Power Losses [kW]	Rated Output Current [A]	Applicable Motor Power		Nominal Power Losses [kW]	
		[HP]	[kW]			[HP]	[kW]			[HP]	[kW]		
6000~6300	55	600	450	9.19	58	700	500	9.43	62	700	500	9.43	C1
	69	750	560	10.28	73	800	630	10.60	78	800	630	10.60	
	86	900	710	11.65	91	1000	800	12.07	97	1000	800	12.07	
	108	1250	900	13.49	114	1350	1000	14.01	122	1350	1000	14.01	
	136	1500	1250	15.95	144	1750	1250	16.68	154	1750	1250	16.68	
	170	2000	1400	19.11	180	2250	1600	20.07	181	2250	1600	20.07	
	198	2250	1800	16.63	212	2500	1900	20.64	228	2500	1900	21.82	C2
	230	2750	2000	21.97	251	3000	2250	23.54	269	3000	2250	24.92	
	267	3000	2250	24.77	295	3500	2700	26.96	317	3500	2700	28.72	
	310	3700	2800	28.16	348	4000	3150	31.27	373	4000	3150	33.38	
	360	4000	3150	32.28	410	4750	3750	36.59	440	4750	3750	39.27	
	423	4500	3750	38.45	481	5500	4300	43.96	516	5500	4300	47.43	
	496	6000	4500	45.43	565	7000	5000	52.45	606	7000	5000	56.81	C3
	583	7000	5000	54.35	664	7500	6000	63.23	713	7500	6000	68.87	
684	8000	6000	65.51	779	9000	7100	76.79	836	9000	7100	83.94		
50	600	450	9.52	54	700	500	9.85	58	700	500	9.85	C1	
63	750	560	10.60	67	800	630	10.93	72	800	630	10.93		
81	900	710	12.13	86	1000	800	12.57	92	1000	800	12.57		
102	1250	900	13.99	109	1350	1000	14.63	117	1350	1000	14.63		
130	1750	1250	16.58	139	1750	1250	17.44	149	1750	1250	17.44		
165	2250	1600	20.01	177	2250	1600	21.23	178	2250	1600	21.23		
192	2500	1900	20.14	205	2750	2000	21.11	221	2750	2000	22.31	C2	
223	3000	2200	22.46	241	3000	2250	23.84	260	3000	2250	25.32		
259	3500	2500	25.24	283	3700	2800	27.15	305	3700	2800	28.95		
301	3750	2800	28.62	332	4000	3150	31.20	358	4000	3150	33.41		
350	4500	3550	32.73	390	4750	3550	36.22	420	4750	3550	38.92		
411	5000	4000	38.77	458	6000	4500	43.26	494	6000	4500	46.84		
482	6500	4750	45.63	538	7250	5000	51.35	580	7250	5000	55.82	C3	
566	7500	5600	54.31	631	8000	6300	61.44	680	8000	6300	67.05		
665	8000	6500	65.31	740	9500	7400	74.20	798	9500	7400	81.41		

(1) Overload capacity:

MX: Maximum Current: overload is not allowed.

ND: Normal Duty: 115 % overload during 60 seconds every 10 minutes.

HD: Heavy Duty: 150 % overload during 60 seconds every 10 minutes.

(2) The motor powers are only illustrative and the correct inverter selection must be done in function of the rated current of the motor to be used, as well as the overloads related to the application.

The rated input currents are equal or less than the rated output currents.

The maximum output currents are allowed during 60 seconds every 10 minutes.

2.3.2 MVW-01 Main Components

Table 2.5: MVW-01 main Components

Suggested tag	Function	Location (column)
A1	Input rectifier	Rectifier
V1	Pre-charge rectifier	
T2	Pre-charge transformer (210 V - 4.3 kV)	
T3	PS1 Power supply transformer (220 V - 22 V)	
F1	Medium voltage fuse for +UD (pre-charge)	
A9.1	ISOY: signal feedback board - rectifier heatsink temperature	
A9.2	ISOY: signal feedback board - medium point to ground voltage	
A9.3	ISOX.00: Signal feedback board - link P and N	
A9.4	ISOX.01: signal feedback board - input voltage	
A9.5	Isolated power supply PS1/PS1S: input: 22 Vac single-phase; output: 15 Vdc	
A15	Medium voltage resistors, for the Medium Point to ground voltage measurement	
BIR	U phase inverter arm	Inverter
BIS	V phase inverter arm	
BIT	W phase inverter arm	
HCTU	U phase Hall effect CT	
HCTV	V phase Hall effect CT	
HCTW	W phase Hall effect CT	
Q1	Main circuit breaker (control) – auxiliary supply for T1	Control
T1	Auxiliary supply transformer. Input: 220 V to 480 V (customer). Output: 220 V PS1S	
Q3	Circuit breaker for T3	
Q2	Circuit breaker for T2	
Q7	Electronics power supply PS24 circuit breaker	
Q4	Rectifier column exhausting fan circuit breaker	
Q5	Inverter column exhausting fans circuit breaker	
AR1	Pre-charge resistors	
A8	Control rack	
A10	MVC3 - main control board	
A11	Electronics power supply PS24: input: 220 Vac three-phase; output: 24 Vdc	
PIC	Power supply and internal I/O board	
A12	MVC4 control board (User interface)	
A13	EBX.XX - Optional function expansion board	
A14	Optional fieldbus board	
HMI	Human Machine Interface	
HVM	DC buss voltage modification board	

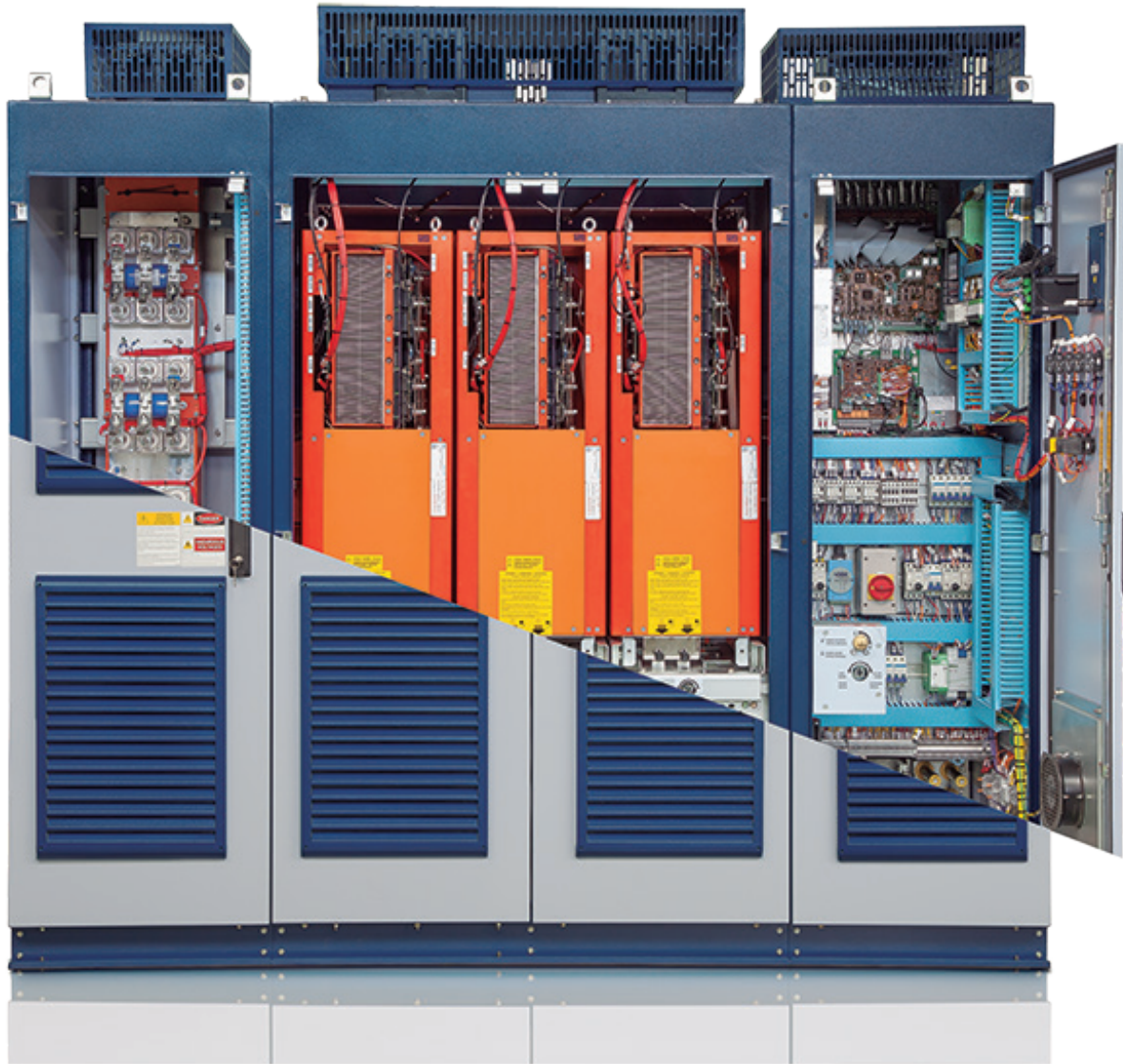
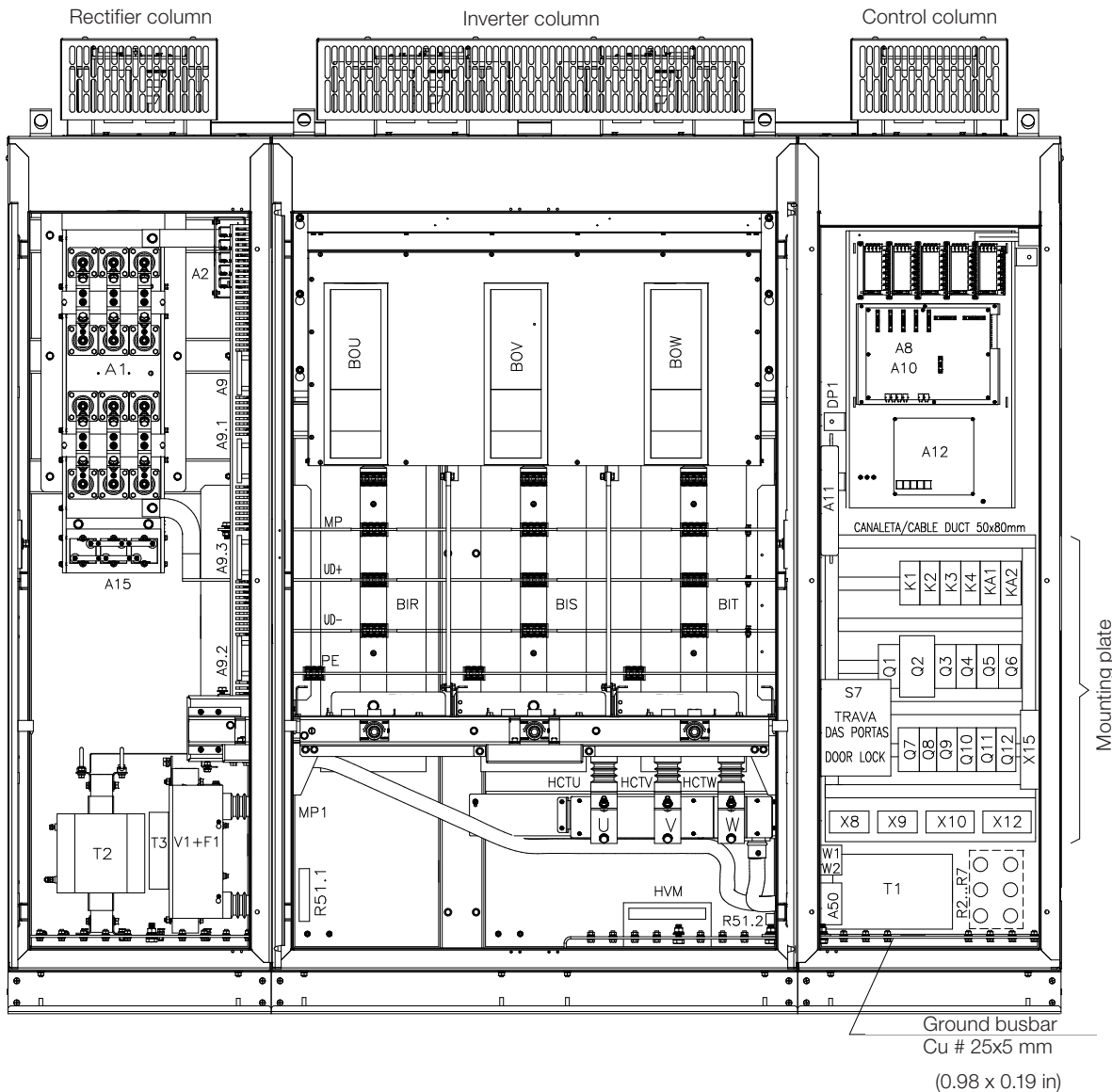

Figure 2.1: MVW-01 Panel general view

The internal component arrangement is presented in the [Figure 2.2 on page 2-10](#) (frame size A).



Rectifier Column	Inverter Column	Control Column
<p>The rectifier column receives the cables from the transformer through the bottom of the cabinet. Besides the power rectifier, this column also contains electronic boards destined to measurements and power supply, medium voltage pre-charge circuit, and medium voltage transformers to supply these circuits. The cabinet has a grounding bar and its door remains closed during the operation. The measured signals are sent to the control column via optical fibers.</p> <div data-bbox="188 1765 539 1888" style="border: 1px solid black; padding: 5px;"> <p>NOTE! Optionally, the cable entry can be placed at the top of the cabinet.</p> </div>	<p>The inverter column contains the inverter extractable arms (BIR, BIS and BIT). Connection bars for the motor medium voltage cables are available, and are accessed via the cabinet bottom. The arm semiconductors are controlled and monitored through fiber optic cables coming from the control column. This column also contains the medium voltage Hall effect current transformers, voltaic arc detection sensors and differential pressure sensor probe used to monitor exhausting fan faults. The cabinet also has a grounding bar and its door remains closed during the operation.</p>	<p>The control column contains the electronic rack composed by the control, fiber optics interface, power supply, I/O, optional (function expansion and communication network) boards, as well as the command and protection circuits destined to the system operation (circuit breaker + transformer + inverter + motor), command transformer, low voltage pre-charge circuit, Human Machine Interface and terminal strips.</p>

Figure 2.2: MVW-01 internal component arrangement (frame size A)

2.3.3 MVW-01 Electronic boards

Table 2.6: MVW-01 electronic boards

	Name	Function	Panel / Module
1	MVC3	Main control	Control / A8 Rack
2	MVC4	User interface control	
3	FOI 3, 4	It converts electrical signals into optical signals and vice versa	
4	PIC2	Power supplies for the electronics, internal use digital inputs and output relays	
5	EBA, EBB, EBC	Optional function expansion boards	
6	Fieldbus	Optional network communication boards	
7	ISOY/ISOZ	Signal feedback boards, they measure medium voltages or temperatures and send the information via optical signals (1 channel)	Rectifier / A9
8	ISOX	Signal feedback boards, they measure medium voltages or temperatures and send the information via optical signals (2 channels)	Rectifier / A9
9	PS24	Electronics power supply: - input: 220 Vac 3 ~ or 220 Vac 1~ - output: 24 Vdc	Control / A11
10	PS1/PS1S	Isolated power supply: - input: 22 Vac 1 ~ (PST) 220 Vac 1~ (PSTS) output: 15 Vdc	Rectifier / A9.5
11	HVM	It indicates that the DC link is energized (Neon lamps)	Inverter (visible in the control)
12	1SD210F2 1SP0335	Gate drivers	Inverter / BIR, BIS, BIT
13	PLC2	PLC expansion board - optional	Control / A8 Rack
14	RSSI	Absolute encoder interface - optional	Control
15	HMI Cables		

2.3.4 PLC2 Expansion Board

The PLC2 board presents the following hardware features:

Table 2.7: PLC2

COMMUNICATION	Serial Interface	<ul style="list-style-type: none"> ■ CANopen Master/Slave and DeviceNet Slave networks. ■ Optional for Profibus DP Slave network. ■ Optional for DeviceNet Slave network.
INPUT	Analog	■ 1 differential analog input (-10 to +10) Vdc or (-20 to +20) mA, 14 bits.
	Incremental Encoder	■ 2 isolated encoder inputs, with external supply of 5 Vdc or (8 to 24) Vdc.
OUTPUT	Digital	<ul style="list-style-type: none"> ■ 9 isolated digital inputs, bidirectional, 24 Vdc. ■ 1 motor PTC input.
	Analog	■ 2 analog outputs (-10 to +10) Vdc or (0 to 20) mA, 12 bits.
	Serial Interface	■ 1 serial communication interface - RS-232C (Standard protocol: MODBUS-RTU).
	Digital	<ul style="list-style-type: none"> ■ 3 relay outputs: 250 V x 3 A. ■ 3 optocoupled digital outputs, bidirectional, 24 Vdc x 500 mA.

2.4 RECEIVING AND STORAGE

The MVW-01 is supplied with the power arms separated from the cabinet and packed individually. The packing is made of an OSB frame and polystyrene foam wedges. There is an identification label outside this package, which is identical to the one attached to the arms. Confront the content of this label with the purchase order.

In order to open the arm packages, refer to the procedure described in the [Item 8.1.5 Unpacking on page 8-3](#).

If the MVW-01 arms are not installed soon in the cabinet, store them in a clean and dry environment (temperature between -25 °C and 50 °C (-13 and 122 °F) and moisture below 80 %) covered up in order to avoid dust accumulation or water splashing

The MVW-01 panel is supplied in a package composed of cardboard and wood. The guidance for handling, transportation, mechanical and electric installation is presented in the [Chapter 8 INSTALLATION, CONNECTION AND ENERGIZATION on page 8-1](#), and in [Item 8.1.5 Unpacking on page 8-3](#).

**ATTENTION!**

It is very important to verify whether the inverter software is of the version indicated in the first page of this manual.

3 MVW-01 WITH 3 LEVELS (3L)

The 3 level MVW-01 is a variable frequency inverter destined to control medium voltage induction motors with nominal voltages of 2300 V, 3300 V, 4160 V and 4600 V and with a power range from 380 HP to 22500 HP. In its standard version it uses non-controlled semiconductors (diodes) at the input rectifier stage and controlled semiconductors (HV-IGBTs) to generate the three output phases at the inverter stage, in order to control the medium voltage motor speed and torque.

The MVW-01 presents protections against overload, short-circuit, phase loss, undervoltage, overvoltage, overtemperature, and ground fault, it also has an independent fault monitoring for each HV-IGBT, has pressure sensors for ventilation efficiency monitoring, and presents output current limitation. The control type can be selected by the user, between scalar control (constant V/f ratio) and vector control (with sensorless or encoder feedback).

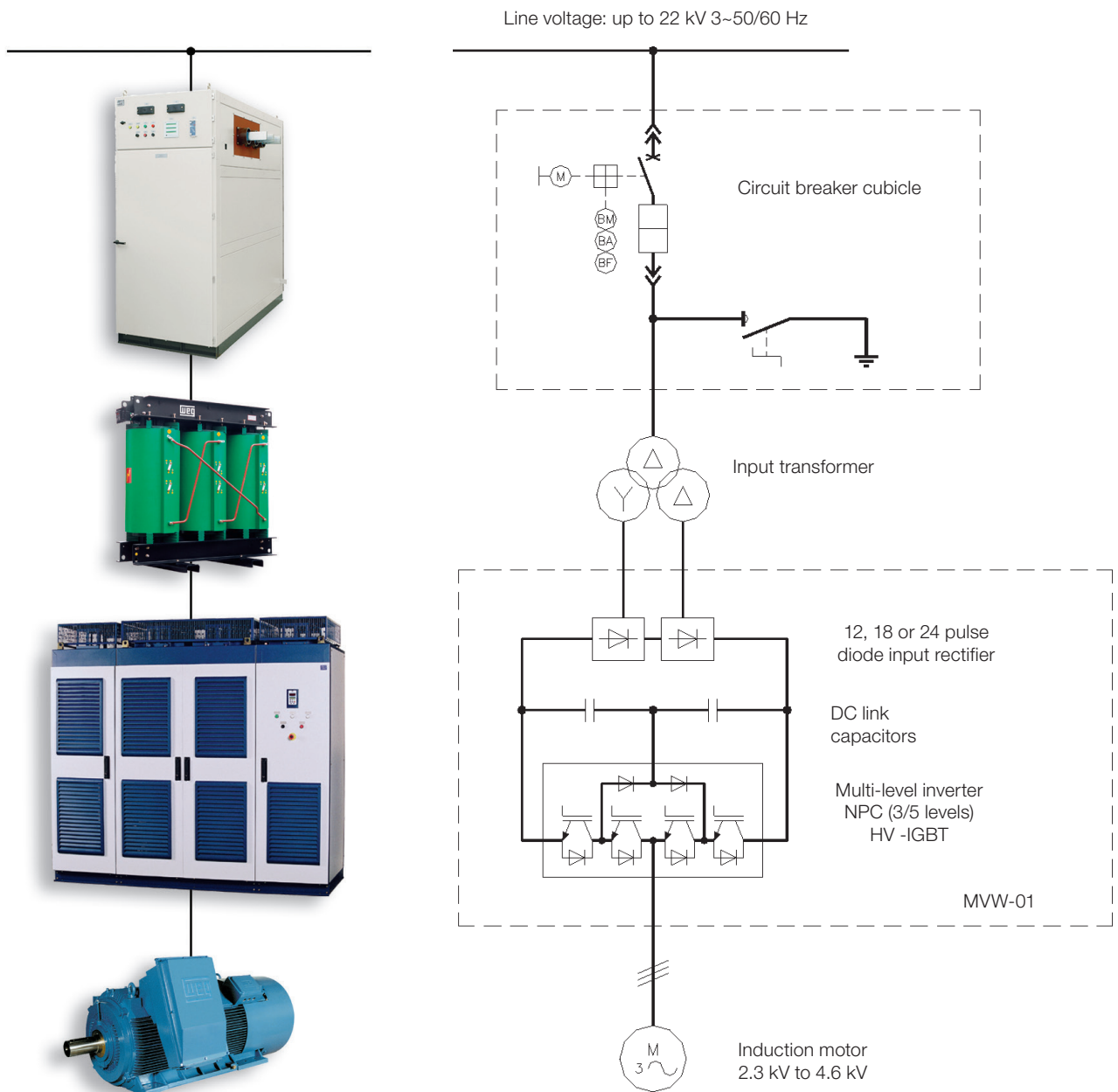

Figure 3.1: General block diagram

The input stage rectifier is a 12-pulse diode bridge (it can be supplied optionally for 18 or 24 pulses). This bridge generates the inverter DC link voltage, receiving the supply voltage from an isolating transformer and a medium voltage circuit breaker. Both the transformer and the circuit breaker may be within the scope of the MVW-01 supply. The minimum specifications of the input transformer are:

- Nominal power according to the inverter power rating considering the input current harmonics.
- Minimum impedance of 6 %.
- Shield between primary and secondary windings.
- Primary voltage according to the available line voltage.
- Secondary voltages according to the motor nominal voltage and 3.6 kV/7.2 kV voltage insulation class.

The DC link is composed by high reliable dry plastic film capacitors with long useful life used for filtering. The capacitor bank is distributed through the three arms and split into two parts by a series connection that creates a medium point dividing the DC link into two voltages, VP and VN.

The medium point is necessary for the NPC - Neutral Point Clamped - inverter implementation, which is composed by 4 HV-IGBTs (4.5 kV or 6.5 kV) and 2 clamping diodes, in a three-level topology.

The complete inverter is assembled inside metallic cabinets with IP41 protection degree.



Figure 3.2: MVW-01 panel (frame size A)

3.1 MECHANICAL DATA

3.1.1 Panel Constructive Aspects

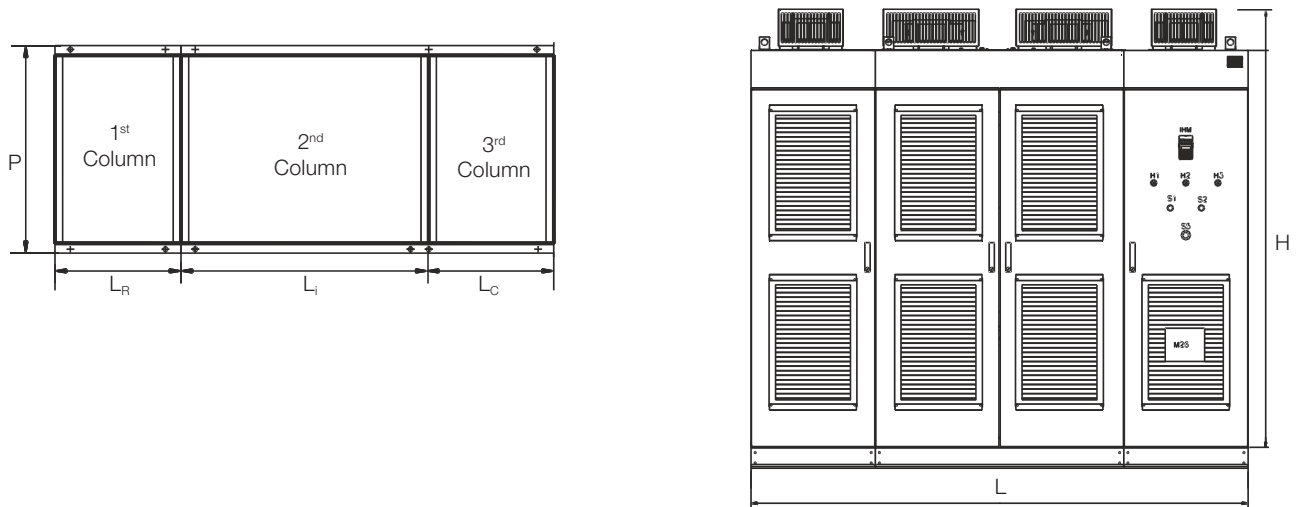

Figure 3.3: Panel constructive aspects

The MVW-01 line is assembled in panels with the dimensions shown in [Table 3.1 on page 3-3](#):

Table 3.1: Mechanical data (dimensions in mm)

Frame Size	L _R (mm)	L _I (mm)	L _C (mm)	L (mm)	H (mm)	P (mm)	Frame size
A0	-	-	-	1000	2316	1000	900
A	600	1200	600	2400	2220	980	1560
B	800	1200	600	2600			1700
C	800	2 x 1280	800	4160			2700
D	1280	3 x 1280	800	5920 *		1000	4500
E	1280	4 x 1280	800	7200 *			5000
2 x D	2 x 1280	6 x 1280	2 x 800	2 x 5920	2 x 4500		
2 x E	2 x 1280	8 x 1280	2 x 800	2 x 7200	2 x 5000		

(*) Frames D and E with 18-pulse rectifier, consider +800 mm for additional column of cable input and output.

The panel cooling is achieved by means of forced ventilation. The cold air enters through the grids located at the front doors, passes through the power section heatsinks, and the hot air is exhausted at the panel tops where the fans are installed.

The MVW-01 has been designed to comply with the CEI – IEC 61800 (part 4 and 5) standard.

The MVW-01 is appropriate for operation in industrial environments, with resistance to chemical agents and to corrosion.

The cabinet is built with painted steel plates that are processed (cutting, drilling, bending, chemical treatment, painting and finishing) at WEG, assuring the cabinet quality. The inverter parts that are not painted are zinc plated or have another suitable treatment in order to assure their resistance against corrosion.

The internal frame is composed by gauge #12 sheet steel (2.65 mm (0.10 in)) whereas the doors and closures are composed by gauge #14 sheet steel. The protection degree is IP41, for indoors environment.

The cooling air enters the panel through front openings protected by grids (one internal and another external) with air filters.

Filter cleaning or replacement can be done by removing the external grid with no need to open the doors and to interrupt the inverter operation. The internal grid with openings smaller than 10 mm prevents the access to the medium voltage compartment.

The hot air exhaustion occurs at the panel top where the exhausting fans are located, making service possible

without opening the medium voltage compartment doors.

The medium voltage compartments (input rectifier and inverter) are mechanically and electrically interlocked in order to prevent the access to all the components that are able to present electric shock danger.

Only after closing the rectifier and the inverter stage doors it becomes possible to lock them by means of a mechanical interlocking device located at the control stage. This device has an electric switch that, once closed, enables the MVW-01 medium voltage energization. The door opening while the inverter is energized is not allowed.

In the event of door unlocking, the inverter disables the operation and switches off the input circuit breaker. The control stage is fed by an auxiliary power supply (220 V - 480 V) and can be locked in order to prevent access.

3.2 INPUT RECTIFIER

3

There are electronic boards in the rectifier column destined to attenuate, measure, convert into frequency and send the following signals, via fiber optic cables, to the control column:

- 2 input transformer secondary line voltages.
- The rectifier heatsink temperature.
- 2 DC link voltages (+UD and -UD) referenced to the medium point (MP).
- The voltage between medium point and ground.

These boards as well as the boards and DC/DC converters present in the inverter arm are fed with 15 Vdc by the PS1/PS1S, and this power supply being fed by the secondary of the high insulation transformer T3.

The medium voltage cables for the input rectifier (A1) supply come from the input transformer secondary windings. The transformer configuration and the number of cables depend on the rectifier number of pulses:

- 12 pulses 6 cables.
- 18 pulses 9 cables.
- 24 pulses 12 cables.

Considering the standard rectifier version (12 pulses) the secondary winding voltage depends on the motor nominal voltage, being 2.2 kV for motors with 4160 V rated voltage, 1.75 kV for motors with 3300 V rated voltage, and 1.21 kV for motors with 2300 V rated voltage. The 6 cables enter the rectifier cabinet at the top or at the bottom and are connected directly to terminals mounted on the rectifier module (A1) copper bars.

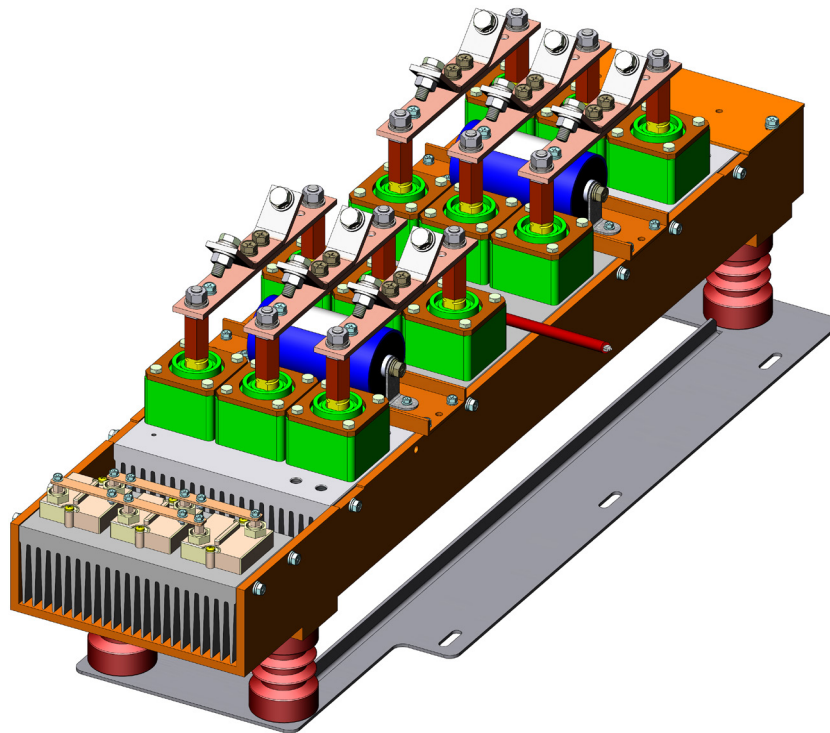

Figure 3.4: MVW-01 12-pulse rectifier

The rectifier is connected to the DC link located at the rear part of the MVW-01 panel. The DC bus supplies the voltage for the three inverter power arms.

3.3 INVERTER ARMS

The inverter arms are identical and contain:

- 4 or 6 filtering capacitors (of dry plastic film).
- 4 medium voltage IGBT modules.
- 1 medium voltage diode module.
- 1 power heatsink.
- 4 gate driver boards (one for each IGBT).
- 4 isolated DC/DC converters (gate driver boards power supply).
- 1 heatsink temperature sensor (NTC resistor).
- 1 NPC resistor.
- 1 ISOX.X2 Signal feedback board.
- 2 Resistors for balancing the DC Bus.

The arm has a mechanical structure formed by bulk molding compound (BMC) (polyester resin and fiberglass).

The singers/pinchers located at the back of the inverter cabinet make the electrical connection of the arms to the busbars. [Chapter 8 INSTALLATION, CONNECTION AND ENERGIZATION on page 8-1](#) describes the arm transportation and installation procedures.

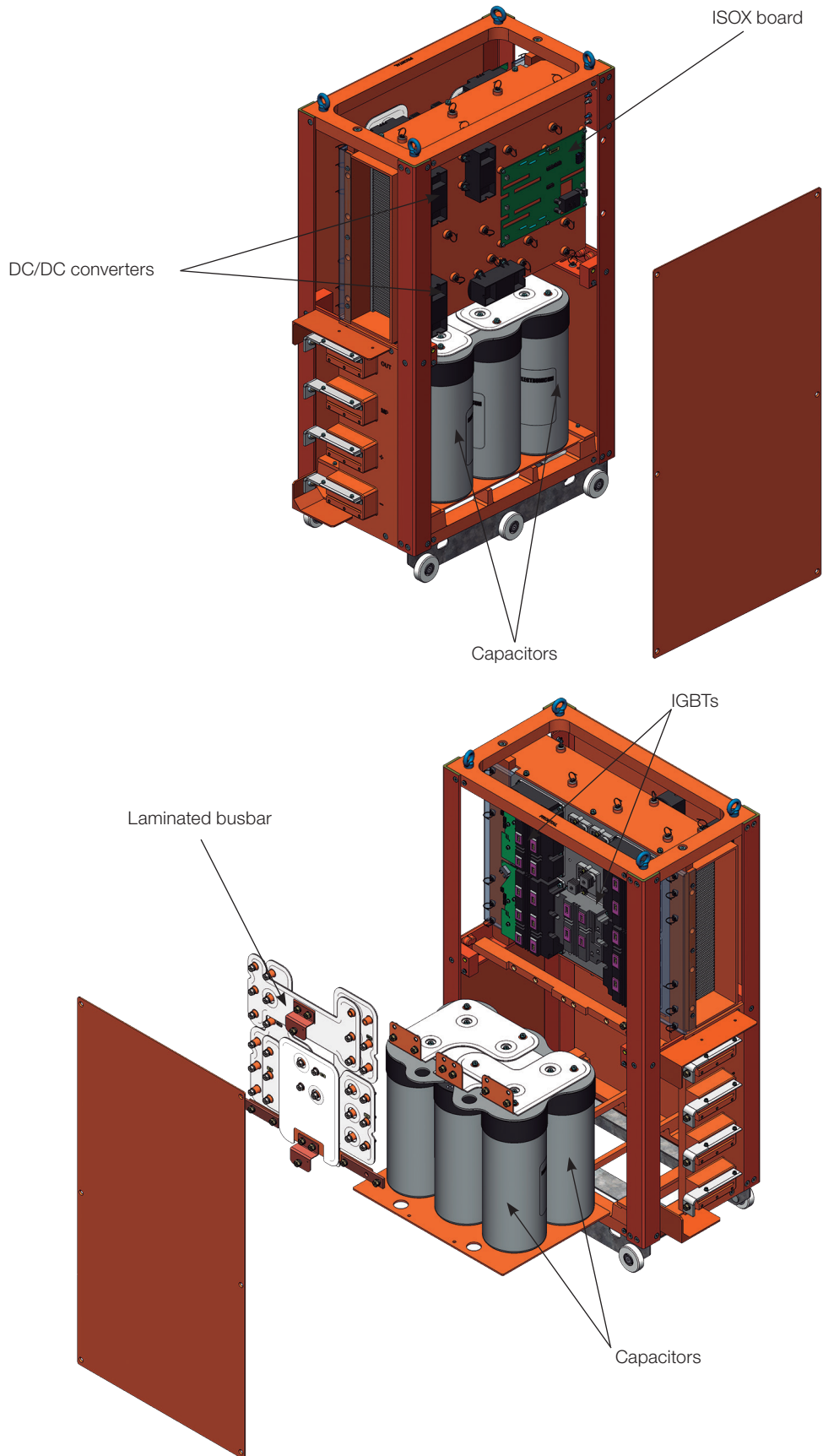

Figure 3.5: MVW-01 Power arm

3.4 CONTROL RACK

Inverter operation:

The inverter uses PWM (Pulsed Width Modulation) modulation technique, in order to produce AC voltage with variable frequency and amplitude, from the DC link voltage, and make it available to the motor at the output terminals. The motor connection terminals are copper bars and the outlet for the medium voltage motor cables is located at the front bottom of the inverter cabinet.

The output current (motor current) is measured using Hall effect CTs in all the three phases, and the current signals are sent to the control board. The inverter uses the measurements to indicate the current and to perform the control and protection functions of the INVERTER + MOTOR system.

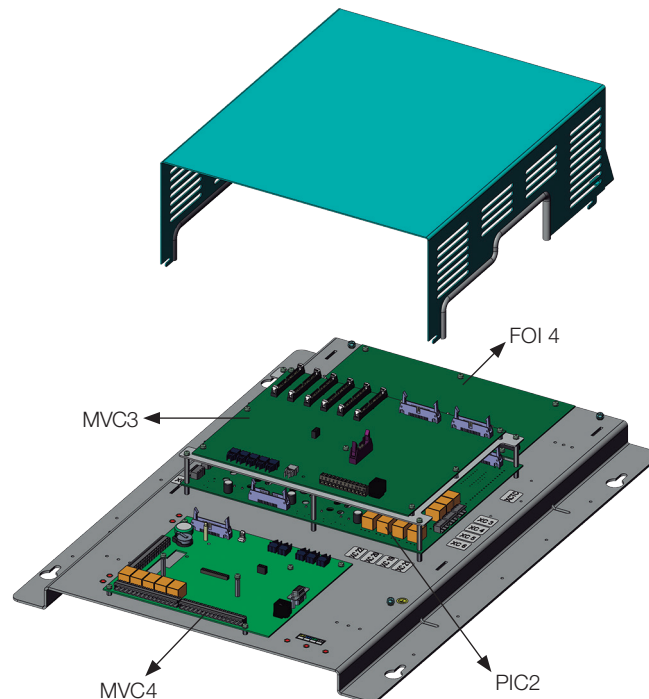

Figure 3.6: MVW-01 standard control rack

Pre-charge:

During the power-up, due to the high inrush current that is necessary to load the DC link, a pre-charge in the DC link becomes necessary, and it is carried out by the rectifier (V1) and the high insulation transformer T2. The pre-charge circuit energizes the primary of this transformer with 220 V. The pre-charge resistors AR1 are also connected to the primary winding of this transformer, but they are installed in the control cabinet. Only after the pre-charge procedure it becomes possible to close the main circuit breaker.

Auxiliary Power Supply:

The auxiliary power supply (220 V - 480 V) must be connected to the specific terminal strip located in the control cabinet. The T1 transformer has taps for different primary voltages and supplies 220 V at the secondary in order to feed the low voltage circuits and the exhausting fans present in the product.

The control rack A8 is fed with 24 Vdc supplied by the PS24 (A11) power supply, whose input is of 220 Vac 1~ or 3 ~. The control rack is composed by the Power Supply and Interface Board (PIC); and by 02 control boards: MVC3 and MVC4. The MVC3 board is responsible for the motor and inverter control, and the MVC4 board performs the user interface tasks. Both boards are fed by low voltages coming from the PIC board, which also contains opto-isolated digital inputs and relay outputs (220 Vac) for internal MVW-01 use.

Optional Fieldbus communication and function expansion boards (EBA, EBB or EBC) can be connected to the MVC4 control board. The connections between the MVC3 board and the power stages are made with fiber-optic cables through the FOI interface boards.



NOTE!

For more information on the boards, refer to the [Item 2.3.3 MVW-01 Electronic boards on page 2-11](#).

3.5 OUTPUT FILTERS

Depending on the installation conditions, the addition of an output dv/dt filter may be necessary, recommended for drive systems with cable length between 100 (328.08 ft) and 500 m (1640.41 ft), which are designed for application with new WEG motors. For drive systems with cable length greater than 500 m (1640.41 ft), or for driving already existent motors (retrofit applications) the use of sinusoidal filters (by consulting WEG) is recommended.

Table 3.2 on page 3-9 presents the line of dv/dt and sinusoidal filters for the MVW-01 inverter, according to the description above.

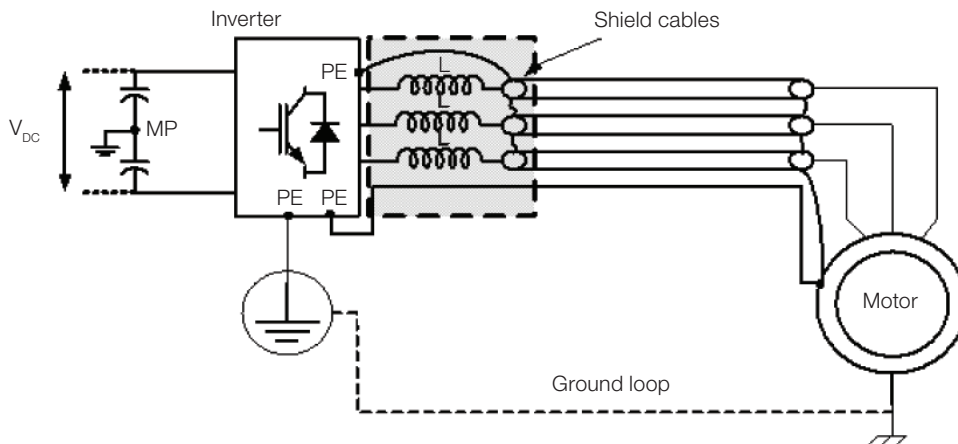

(a) Output reactor - solution for cable length between 100 and 200 m (328.08 and 656.17 ft).

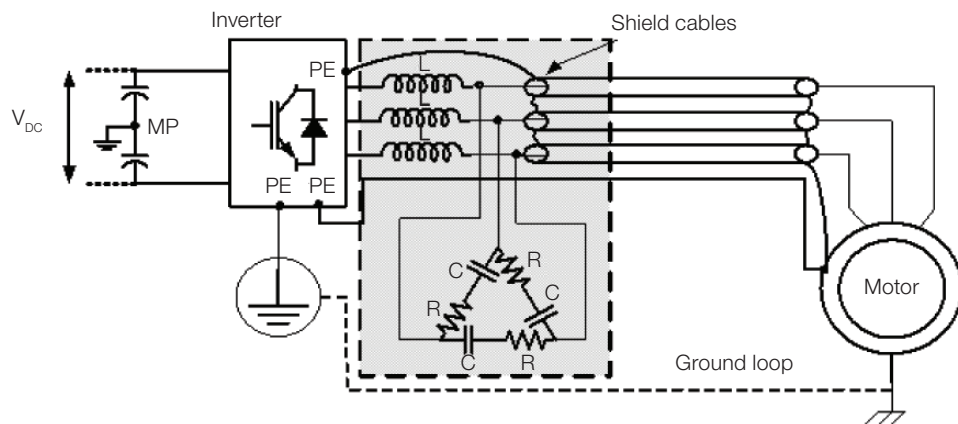

(b) RLC dv/dt filter - solution for cable length between 200 and 500 m (656.17 and 1640.41 ft).

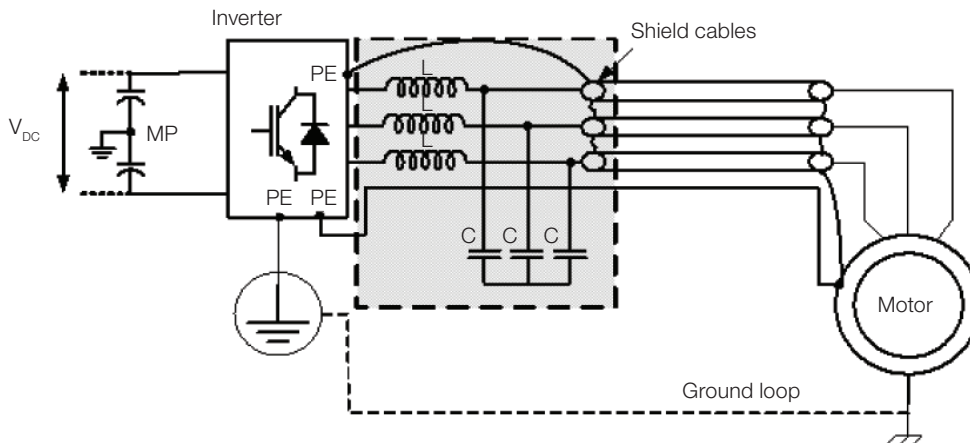

(c) Sinusoidal filter - solution for cable length greater than 500 m (1640.41 ft), or for retrofit applications.

Figure 3.7: (a) to (c) Output filters for MVW-01 inverters

Table 3.2: Output filters for MVW-01 inverters

Motor Cables Length	Inverter Model: Nominal Current (CT) / Size	Output dv/dt Filter	Components
Up to 100 m (328.08 ft)	All models	It is not necessary	-
> 100 m to 200 m (328.08 and 656.17 ft)	4160 V / frame size A0 4160 V / frame size A 3300 V / frame size A0 3300 V / frame size A 2300 V / frame size A 2300 V / frame size B	Output reactor with 2 % voltage drop	Reactor according to WEG specification
	4160V / frame size C, D and E 3300V / frame size C, D and E	It is not necessary	-
> 200 m to 500 m (656.17 and 1640.41 ft)	4160 V / frame size A 3300 V / frame size A 2300 V / frame size A 2300 V / frame size B	RLC 01 dV/dt filter	Reactor according to WEG specification RC01 set
	4160 V / frame size C 3300 V / frame size C	RLC 02 dV/dt filter	RC02 set
> 500 m (1640.41 ft)	All models	Sinusoidal filter	Under consultation to WEG

3.5.1 Sinusoidal Output Filter

WEG sinusoidal filters have been developed with the purpose of reducing the voltage and current harmonic content at medium voltage motors power supply. They are compatible with new or already existent motors, and make it possible to drive motors without distance limitation between the MVW-01 and the motor.

Besides the inductor and the capacitor, the sinusoidal filter is formed by a contactor in series with the capacitive branch. This contactor has the function of disconnecting the capacitors in case of an inverter failure, avoiding, thereby, resonances between the filter and the motor. The need to use the contactor must be evaluated for each application.

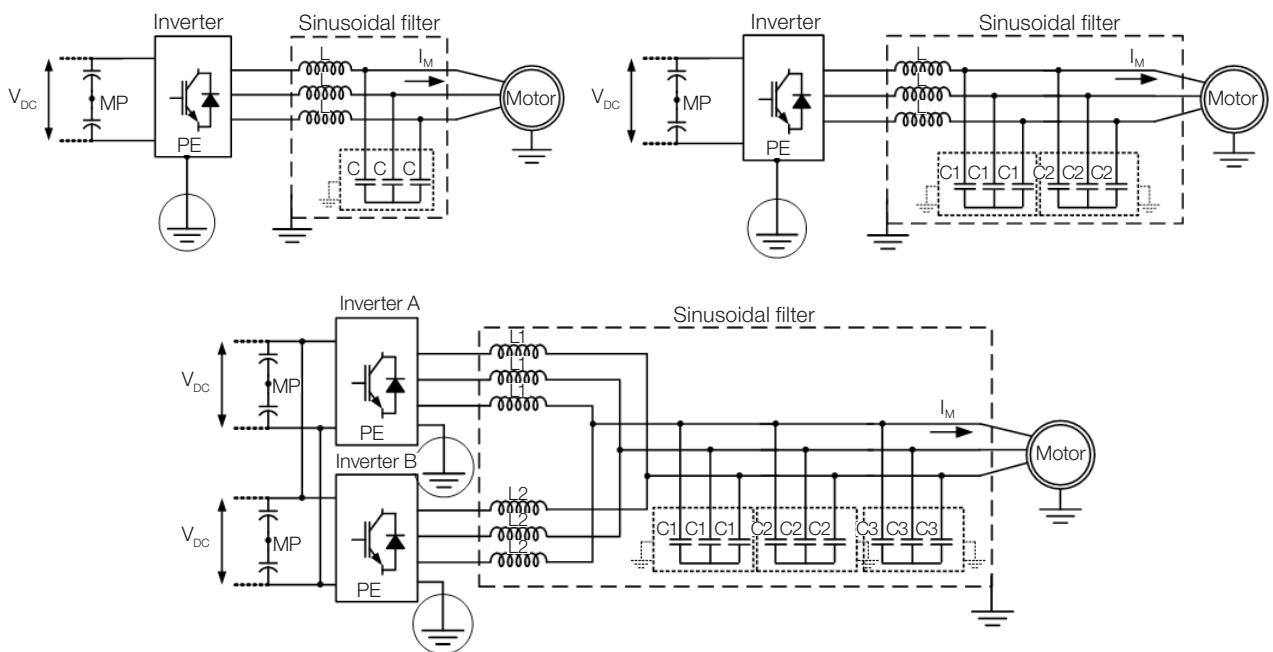
Figure 3.8: Possible configurations of sinusoidal filters

NOTE!

When the product features the option “**sinusoidal output filter**”, the inverter comes from the factory enabled to operate with it. However, this function will be only available in the scalar control mode (P202 = 0, 1 or 2) and when specified in the project requirements.

The parameter P011, Inverter Current was added because of the use of the inverter with sinusoidal output filter. It is intended to differentiate the inverter output current from the motor current after the filter. [Figure 3.8 on page 3-9](#) illustrates this difference.

Besides the creation of P011, parameters P003 and P400 were changed in order to adapt the use of the MVW-01 with sinusoidal output filter. The description of these parameters can be found in [Chapter 11 DETAILED PARAMETER DESCRIPTION](#) on page 11-1.

3.6 AVAILABLE MODELS

Refer to the [Table 2.1 on page 2-4](#) and the [Table 2.3 on page 2-6](#).

4 MVW-01 WITH 5 LEVELS (5L)

The MVW-01 5L line intends to meet the demand at lines with higher voltages and, thus, a specific topology and modulation are used.

The MVW-01 5L inverter line operates with the power section structure of H-type bridges connected in star, allowing the inverter operation in 5 levels.

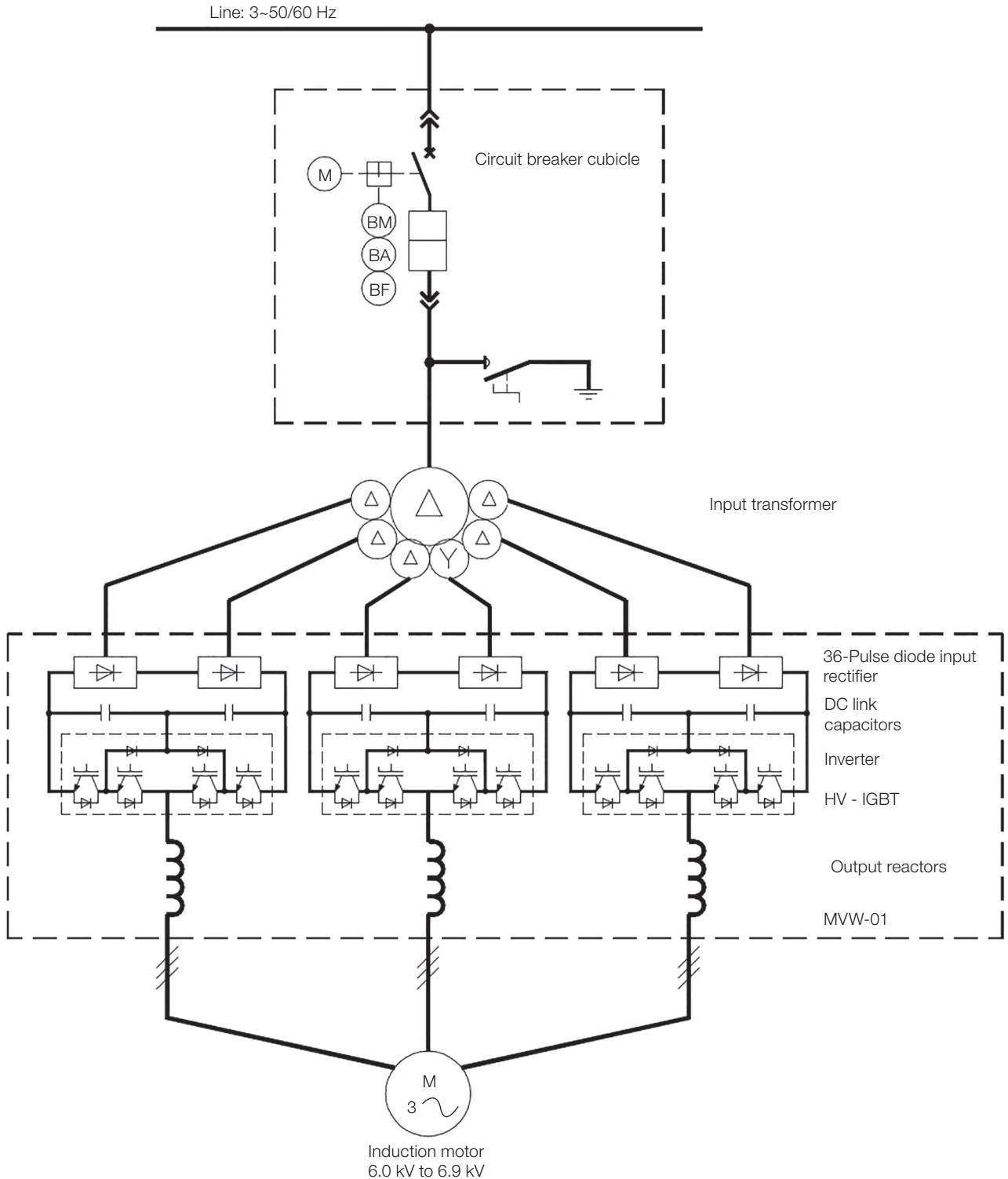

Figure 4.1: Power section structure of the 6.9 kV line

Considering that 3 isolated DC links are necessary in this topology, new parameters for the voltage readings of these busses were added, together with the new parameters for the temperature reading of the rectifiers, added to feed these new DC links.

Table 4.1: Nomenclature regarding the rectifier and DC bus parameters used for each H bridge

H Bridge Reference Phase	Rectifier Temperature Reading Parameter		DC Buss Voltage Reading Parameter	
	Nomenclature	Parameter	Nomenclature	Parameter
U	TEMP R1	P059	Vdc (+) U	P053
			Vdc (-) U	P052
V	TEMP R2	P088	Vdc (+) V	P093
			Vdc (-) V	P092
W	TEMP R3	P089	Vdc (+) W	P095
			Vdc (-) W	P094

4.1 MECHANICAL DATA

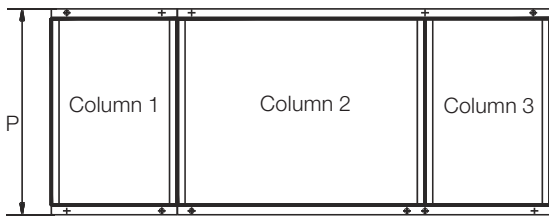

Frame Size	L (mm)	H (mm)	P (mm)	Weight (kg) (lb)
C1	1800	2306	1200	1700 (3747.8)
C2	3300	2225	1000	3100 (6834.3)
C3	7480			5000 (11023.1)

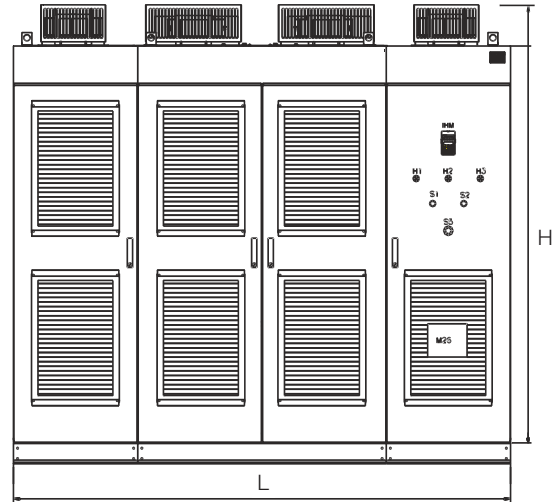

Figure 4.2: Dimensions of the complete MVW-01 panel (in mm)

4.2 AVAILABLE MODELS

Table 4.2: G1 - 5 level models

Nominal Voltage [V]	Heavy Duty - HD ⁽¹⁾				Normal Duty - ND ⁽¹⁾				Frame Size
	Rated Output Current [A]	Applicable Motor Power		Nominal Power Losses [kW]	Rated Output Current [A]	Applicable Motor Power		Nominal Power Losses [kW]	
		[HP]	[kW]			[HP]	[kW]		
6000~6300	44	420	320	8.12	58	500	373	9.44	C1
	59	500	373	9.54	78	750	560	11.44	
	79	750	560	11.55	104	1000	750	14.23	
	95	900	680	13.24	124	1500	1120	16.52	
	107	1000	750	14.57	140	1750	1300	18.45	
6600~6900	40	420	320	8.11	53	500	373	9.36	C1
	53	500	373	9.36	70	750	560	11.08	
	72	750	560	11.29	94	1000	750	13.67	
	85	900	680	12.68	112	1500	1120	15.73	
	99	1000	750	14.23	130	1750	1300	17.89	

(1) Overload capacity:
 ND: Normal Duty: 115 % overload during 60 seconds every 10 minutes.
 HD: Heavy Duty: 150 % overload during 60 seconds every 10 minutes.

Table 4.3: G2 - 5 level models

Nominal Voltage [V]	Heavy Duty - HD ⁽¹⁾				Normal Duty - ND ⁽¹⁾				Maximum Current - MX ⁽¹⁾				Frame Size
	Rated Output Current [A]	Applicable Motor Power		Nominal Power Losses [kW]	Rated Output Current [A]	Applicable Motor Power		Nominal Power Losses [kW]	Rated Output Current [A]	Applicable Motor Power		Nominal Power Losses [kW]	
		[HP]	[kW]			[HP]	[kW]			[HP]	[kW]		
6000~6300	55	600	450	9.19	58	700	500	9.43	62	700	500	9.43	C1
	69	750	560	10.28	73	800	630	10.60	78	800	630	10.60	
	86	900	710	11.65	91	1000	800	12.07	97	1000	800	12.07	
	108	1250	900	13.49	114	1350	1000	14.01	122	1350	1000	14.01	
	136	1500	1250	15.95	144	1750	1250	16.68	154	1750	1250	16.68	
	170	2000	1400	19.11	180	2250	1600	20.07	181	2250	1600	20.07	
	198	2250	1800	16.63	212	2500	1900	20.64	228	2500	1900	21.82	C2
	230	2750	2000	21.97	251	3000	2250	23.54	269	3000	2250	24.92	
	267	3000	2250	24.77	295	3500	2700	26.96	317	3500	2700	28.72	
	310	3700	2800	28.16	348	4000	3150	31.27	373	4000	3150	33.38	
	360	4000	3150	32.28	410	4750	3750	36.59	440	4750	3750	39.27	
	423	4500	3750	38.45	481	5500	4300	43.96	516	5500	4300	47.43	C3
	496	6000	4500	45.43	565	7000	5000	52.45	606	7000	5000	56.81	
583	7000	5000	54.35	664	7500	6000	63.23	713	7500	6000	68.87		
684	8000	6000	65.51	779	9000	7100	76.79	836	9000	7100	83.94		
6600~6900	50	600	450	9.52	54	700	500	9.85	58	700	500	9.85	C1
	63	750	560	10.60	67	800	630	10.93	72	800	630	10.93	
	81	900	710	12.13	86	1000	800	12.57	92	1000	800	12.57	
	102	1250	900	13.99	109	1350	1000	14.63	117	1350	1000	14.63	
	130	1750	1250	16.58	139	1750	1250	17.44	149	1750	1250	17.44	
	165	2250	1600	20.01	177	2250	1600	21.23	178	2250	1600	21.23	
	192	2500	1900	20.14	205	2750	2000	21.11	221	2750	2000	22.31	C2
	223	3000	2200	22.46	241	3000	2250	23.84	260	3000	2250	25.32	
	259	3500	2500	25.24	283	3700	2800	27.15	305	3700	2800	28.95	
	301	3750	2800	28.62	332	4000	3150	31.20	358	4000	3150	33.41	
	350	4500	3550	32.73	390	4750	3550	36.22	420	4750	3550	38.92	
	411	5000	4000	38.77	458	6000	4500	43.26	494	6000	4500	46.84	C3
	482	6500	4750	45.63	538	7250	5000	51.35	580	7250	5000	55.82	
	566	7500	5600	54.31	631	8000	6300	61.44	680	8000	6300	67.05	
665	8000	6500	65.31	740	9500	7400	74.20	798	9500	7400	81.41		

(1) Overload capacity:

MX: Maximum Current: overload is not allowed.

ND: Normal Duty: 115 % overload during 60 seconds every 10 minutes.

HD: Heavy Duty: 150 % overload during 60 seconds every 10 minutes.

(2) The motor powers are only illustrative and the correct inverter selection must be done in function of the rated current of the motor to be used, as well as the overloads related to the application.

The rated input currents are equal or less than the rated output currents.

The maximum output currents are allowed during 60 seconds every 10 minutes.

5 MVW-01C (COMPACT)

The line MVW-01C is a variable frequency inverter destined to control medium voltage induction motors with nominal voltages of 2300 V, 3300 V and 4160 V, with a power range from 500 to 1200 HP. It uses non-controlled semiconductors (diodes) at the input rectifier stage and controlled semiconductors (HV-IGBTs) to generate the three output phases at the inverter stage, in order to control the medium voltage motor speed and torque.

The MVW-01C inverter line uses the same topology as the MVW-01 line and has as the main feature compact dimensions. In order to achieve such dimensional reduction, all the inverter components are scaled to the power range of this product line. Another feature of this line is that in its standard version the inverter uses an 18 pulse rectifier bridge, which demands a special transformer with 3 secondary windings and 20° phase shift among them.

The MVW-01C presents protections against overload, short-circuit, phase loss, undervoltage, overvoltage, overtemperature, and ground fault, it also has an independent fault monitoring for each HV-IGBT, has pressure sensors for ventilation efficiency monitoring, and presents output current limitation. The control type can be selected by the user, between scalar control (constant V/f ratio) and vector control (with sensorless or encoder feedback).

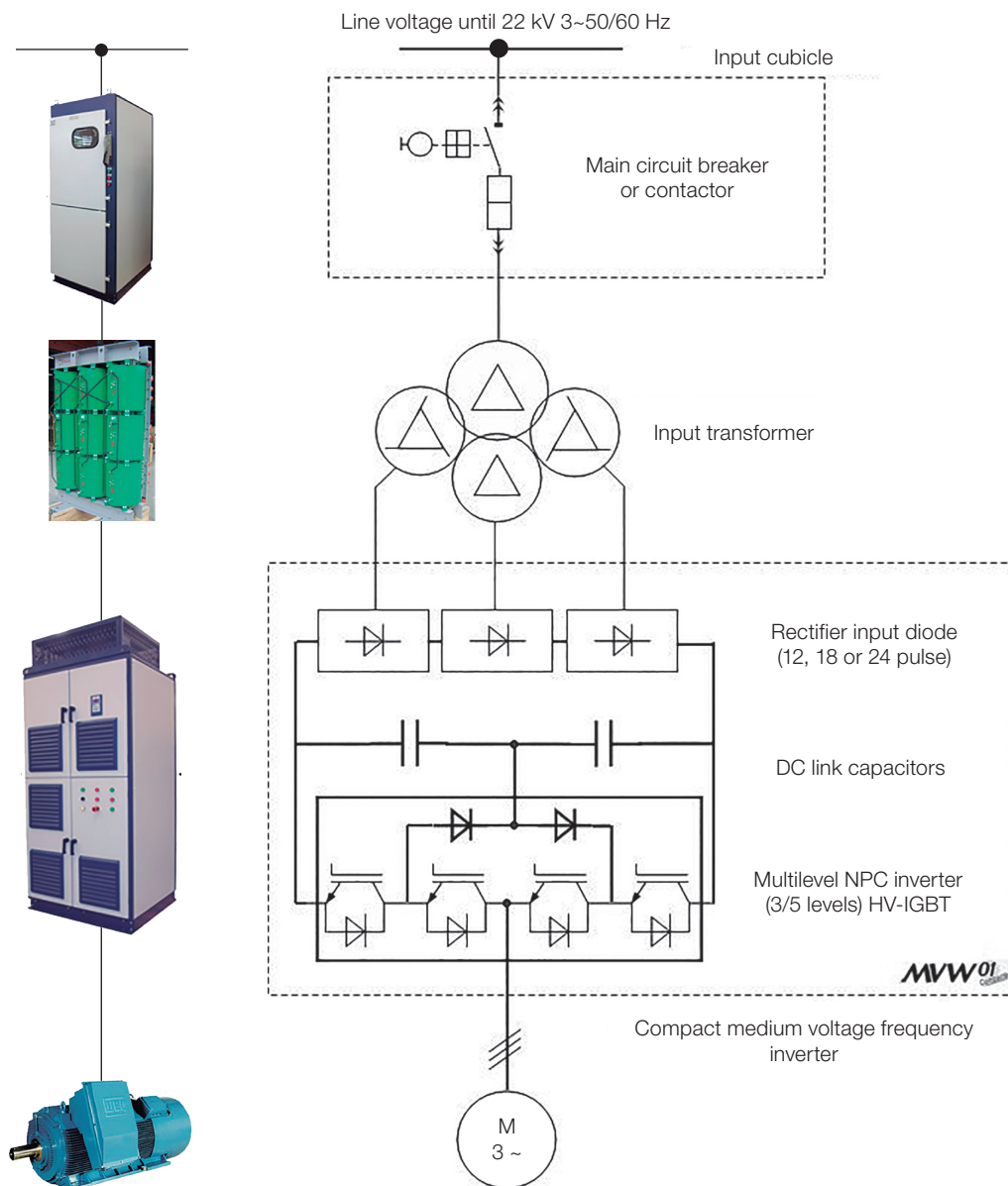

Figure 5.1: General block diagram



Figure 5.2: MVW-01C panel

Transformer

An isolating transformer is required to provide the number of secondary windings necessary to the rectifier bridge and the appropriate voltage level. The minimum specifications of the input transformer are:

- Nominal power according to the inverter power rating considering the input current harmonics.
- Minimum impedance of 6 %.
- Shield between primary and secondary windings.
- Primary voltage according to the available line voltage.
- Secondary voltages according to the motor nominal voltage and 7.2 kV voltage insulation class.

Input Rectifier

The medium voltage cables for the input rectifier (A1) supply come from the input transformer secondary windings. The transformer configuration and the number of cables depend on the rectifier number of pulses:

- 6 cables for the 12 pulse configuration.
- 9 cables for the 18 pulse configuration.
- 12 cables for the 24 pulse configuration.

Considering the standard rectifier version (18 pulses) the secondary winding voltage depends on the motor nominal voltage, being 1.5 kV for motors with 4160 V rated voltage and 1.2 kV for motors with 3300 V rated voltage. The 9 cables may be inserted through the bottom part of the rectifier cabinet or through the top of the inverter cabinet,

being connected directly to terminations in copper bars mounted on the module (A1).

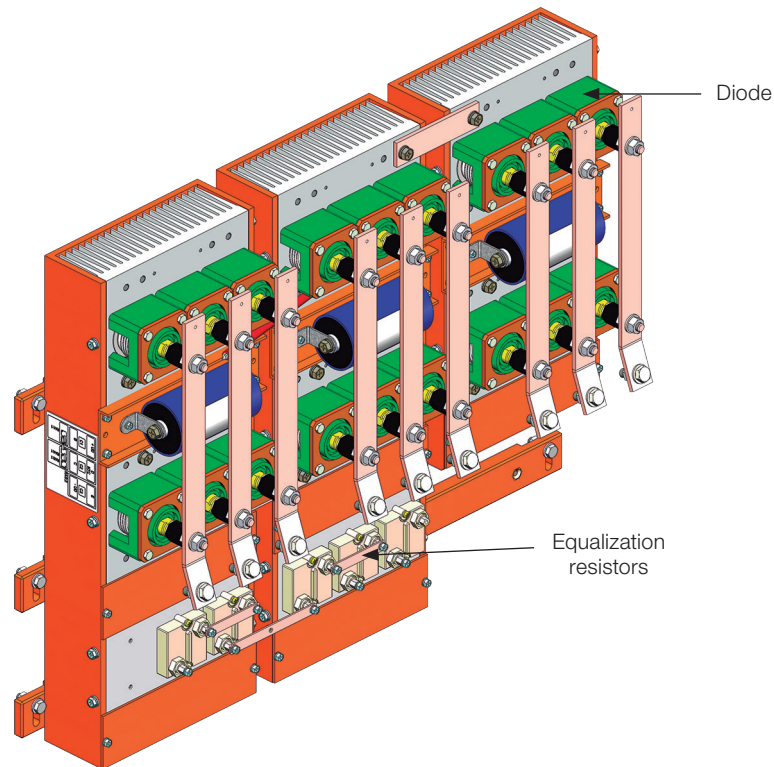

Figure 5.3: MVW-01C 18-pulse rectifier

The rectifier is connected to the DC link located at the rear part of the MVW-01C panel, at the inverter compartment. The resistors for the DC bus voltage balancing are mounted together with the rectifier. The DC voltage feeds the three inverter power arms.

DC Link

The MVW-01 DC link consists of 4 dry plastic film capacitors of high reliability and long service life, designed for the filtering. The capacitor bank is mounted independent from the inverter arms and is divided in 2 parts by means of a series/parallel connection of the capacitors, creating a medium point (MP), necessary for the inverter implementation, which divides the DC link voltage in two (VP and VN). There are three connections available at the capacitor bank, +UD, -UD and MP.

The connection between inverter arms and the DC link capacitor bank is done by finger contacts and the connection between the DC link and the rectifier is done using cables.

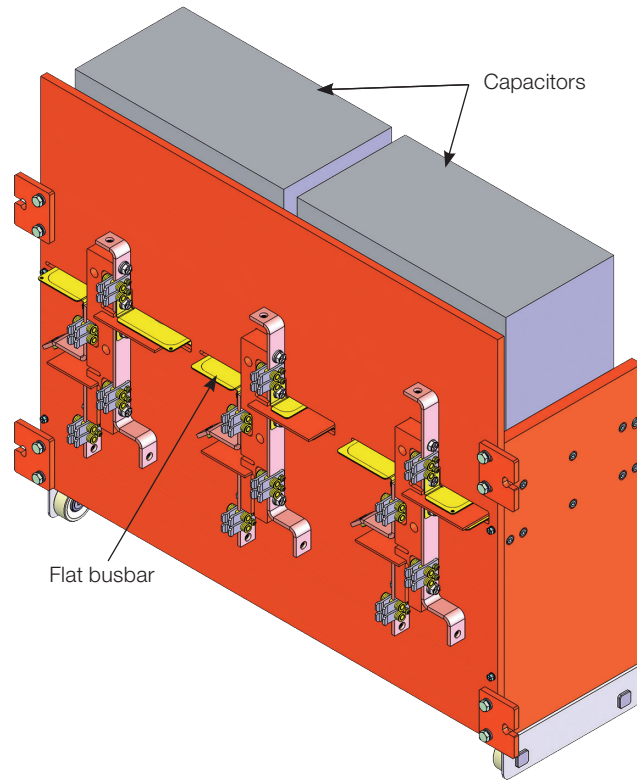

Figure 5.4: MVW-01C DC link capacitor bank

Inverter Arms

The inverter arms are identical and contain:

- 04 medium voltage IGBT modules.
- 01 medium voltage diode module.
- 01 power heatsink.
- 01 Flat busbar.
- 04 gate driver boards (one for each IGBT).
- 04 gate driver adapter boards.
- 04 isolated DC/DC converters (gate driver board power supply).
- 01 heatsink temperature sensor (NTC resistor).
- 01 ISOX.02 Signal Feedback Board.
- 01 NPC resistor.

The arm has mechanical structure formed by bulk molding compound (BMC) (polyester resin and fiberglass) and steel plates, chemically treated to ensure resistance to corrosion.

The electric connection of the arms to the power busbars of the DC link is done by means of finger contacts located at the front of the capacitor bank.

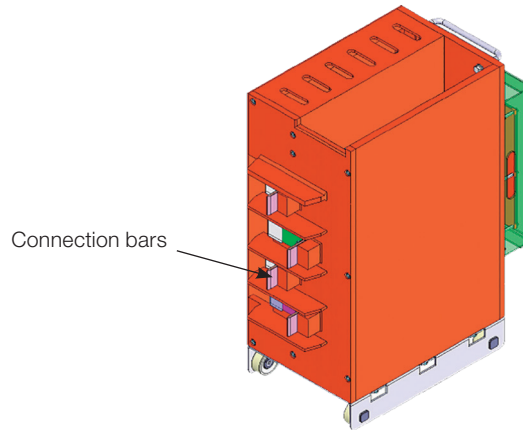

Figure 5.5: MVW-01C power arm

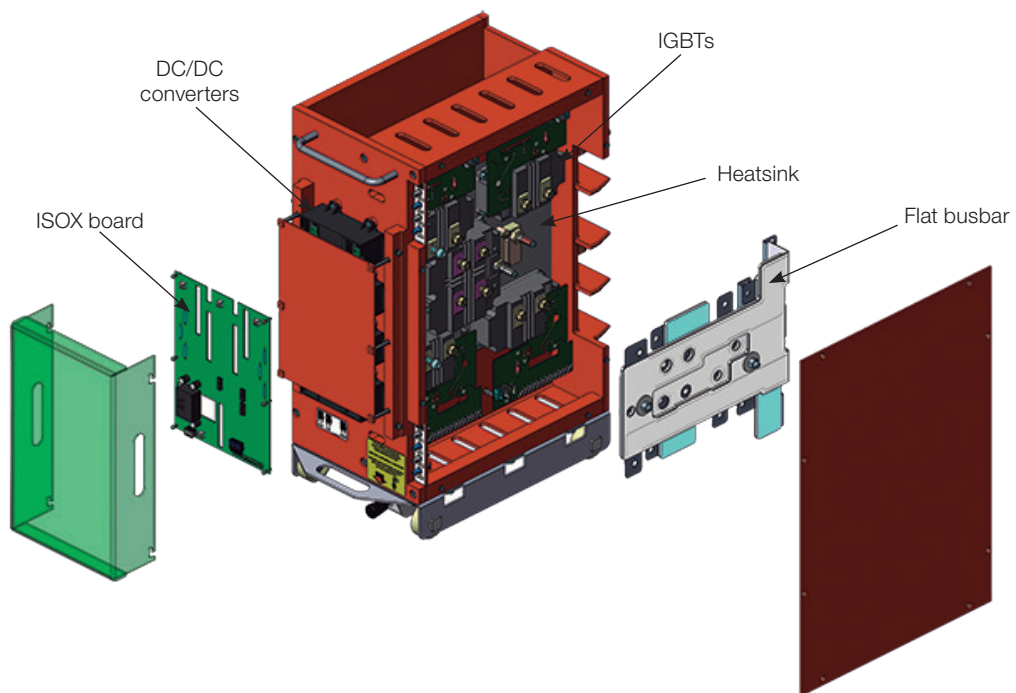

Figure 5.6: MVW-01C Power arm

Control rack

The control rack used in the MVW-01C inverter line has the same functions and uses the same boards of the rack used in the MVW-01 3L line. Refer to the [Section 3.4 CONTROL RACK on page 3-7](#) for the description of the functions, control rack and optional boards.

It is observed only a change in the arrangement of the boards because of the need for compaction of the MVW-01C line.

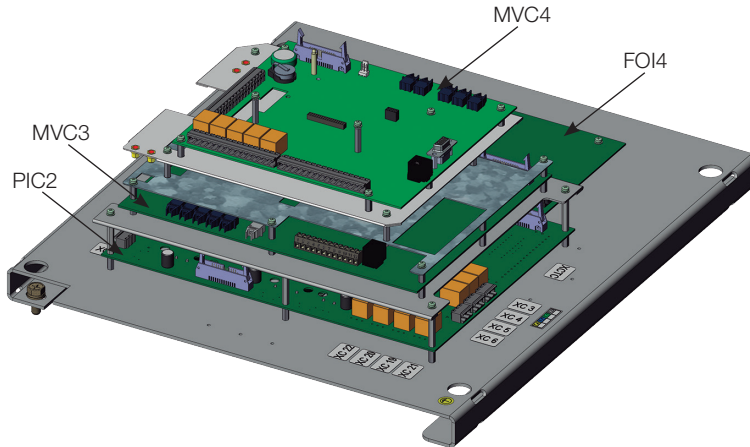

Figure 5.7: MVW-01C control rack

5.1 PANEL CONSTRUCTIVE DETAILS

The MVW-01C is supplied in form of a panel with the dimensions: 1000 mm x 2312 mm x 980 mm (width x height x depth). The complete panel can be defined, according to the components mounted in each panel division and to their functions, as the union of three compartments:

5

- Rectifier Compartment.
- Inverter Compartment.
- Control Compartment.

The Figure 5.8 on page 5-6 shows the complete panel drawing. The inverter arms are supplied separately in proper packages.

Arm dimensions: 260 mm x 607 mm x 522 mm (width x height x depth).

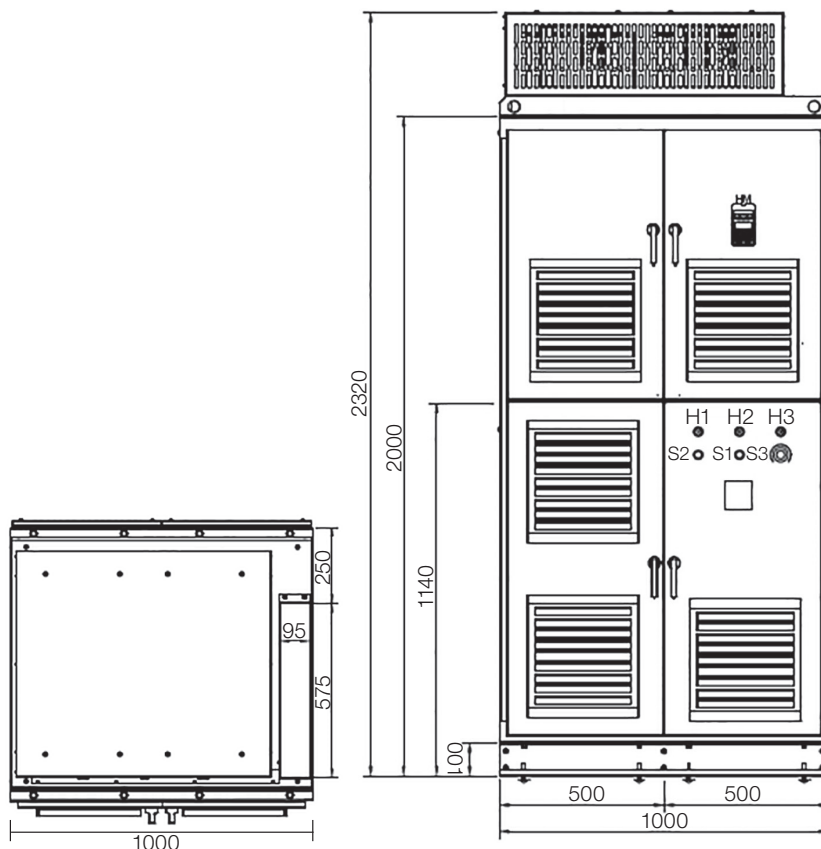

Figure 5.8: Dimensions of the MVW-01C panel

The internal component distribution is presented in the [Figure 5.9 on page 5-7](#).

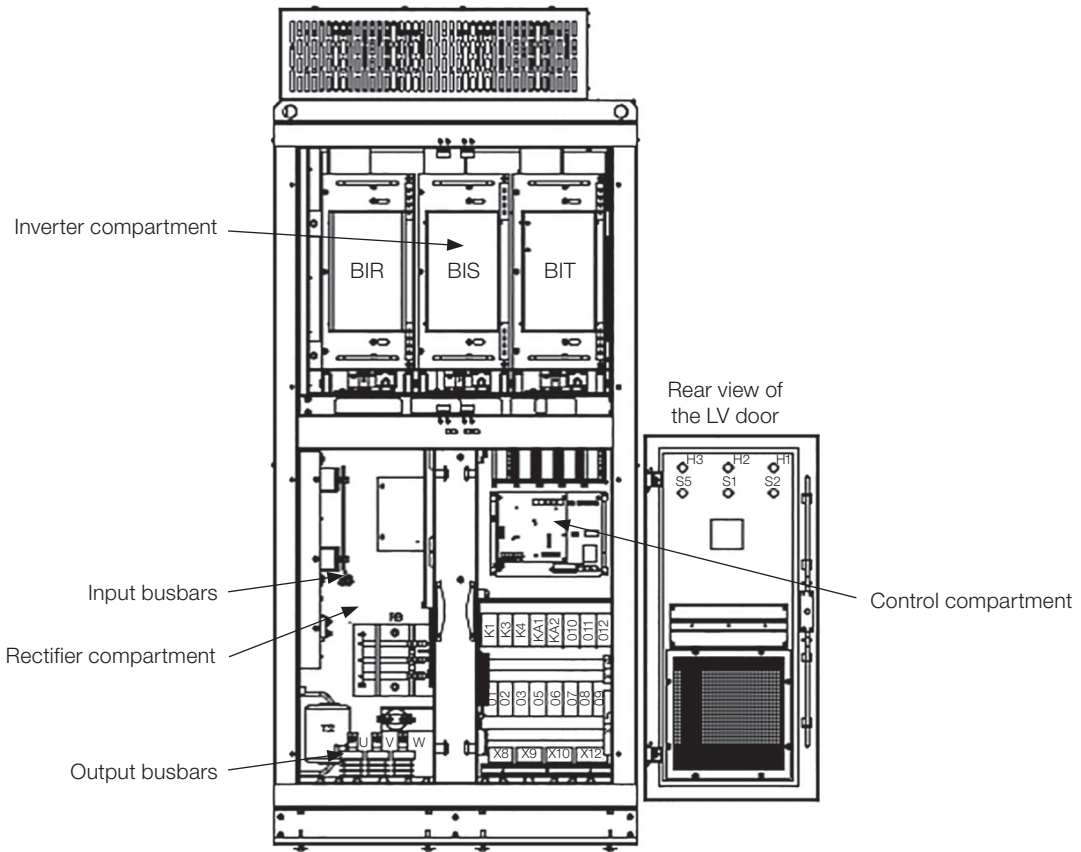

Figure 5.9: MVW-01C internal component arrangement

5.2 AVAILABLE MODELS

Table 5.1: MVW-01C - G1 models

Nominal Voltage [V]	Heavy Duty - HD ⁽¹⁾				Normal Duty - ND ⁽¹⁾			
	Rated Output Current [A]	Applicable Motor Power		Nominal Power Losses [kW]	Rated Output Current [A]	Applicable Motor Power		Nominal Power Losses [kW]
		[HP]	[kW]			[HP]	[kW]	
2300	85	380	280	3.54	97	430	320	4.10
	100	440	330	4.24	112	500	370	4.82
	112	490	373	4.82	125	550	420	5.49
	125	550	416	5.49	138	600	450	6.17
3300	85	500	400	4.71	97	600	450	5.14
	100	600	450	5.14	112	700	500	5.51
	112	700	500	5.51	128	800	630	6.36
	125	750	560	5.95	138	850	670	6.61
4160	70	500	400	5.14	80	600	450	5.43
	80	600	450	5.43	91	700	500	5.85
	94	700	500	5.85	110	800	630	6.38
	110	800	630	6.38	120	900	710	6.72
	120	900	710	6.72	130	1000	800	7.07

⁽¹⁾ Capacity:

ND: Normal Duty: 115 % overload during 60 seconds every 10 minutes

HD: Heavy Duty: 150 % overload during 60 seconds every 10 minutes.

Table 5.2: MVW-01C - G2 models

Nominal Voltage [V]	Heavy Duty - HD ⁽¹⁾				Normal Duty - ND ⁽¹⁾				Maximum Current - MX ⁽¹⁾			
	Rated Output Current [A]	Applicable Motor Power		Nominal Power Losses [kW]	Rated Output Current [A]	Applicable Motor Power		Nominal Power Losses [kW]	Rated Output Current [A]	Applicable Motor Power		Nominal Power Losses [kW]
		[HP]	[kW]			[HP]	[kW]			[HP]	[kW]	
3300	85	500	400	4.38	96	600	450	4.89	98	600	450	4.95
	99	600	450	4.99	113	700	500	5.61	116	700	500	5.75
	115	750	560	5.70	131	800	630	6.44	134	800	630	6.58
	134	800	630	6.58	152	900	710	7.45	155	900	710	7.55
	155	900	710	7.60	176	1100	850	8.65	180	1100	850	8.86
4160	70	550	400	4.60	78	600	450	4.97	85	600	450	5.29
	83	650	500	5.20	92	700	560	5.63	101	700	560	6.06
	98	750	600	5.92	108	850	630	6.41	118	850	630	6.91
	115	900	630	6.76	128	1000	710	7.42	140	1000	710	8.04
	135	1100	800	7.78	151	1200	900	8.63	165	1200	900	9.38

⁽¹⁾ Capacity:

MX: Maximum Current: overload is not allowed.

ND: Normal Duty: 115 % overload during 60 seconds every 10 minutes

HD: Heavy Duty: 150 % overload during 60 seconds every 10 minutes.

6 INVERTER PARALLELISM

The MVW-01 frequency inverter has a wide range of currents that comprise parallel arrangements of conventional models with the use of reactors.



NOTE!

A 5 % derating is applied to each parallel unit in order to compensate the power drop caused by the use of the reactor.

6.1 STRUCTURE OF THE PARALLEL INVERTER

Up to four inverters can be connected in parallel, by means of reactors, in order to extend the power range of the MVW-01 line. In this manual the standard inverter (not parallel) is identified as 3L, with two in parallel 3L2, with three in parallel 3L3, and with four in parallel 3L4.

The parameters and faults regarding the parallel inverter (3L2) suffered modifications in the arm nomenclature in order to adequate it to the new 6.9 kV inverter line and to the expansion of the existent 3300 V and 4160 V lines. The figure below presents the power section structure of the inverter with the new HMI parameter correspondence.

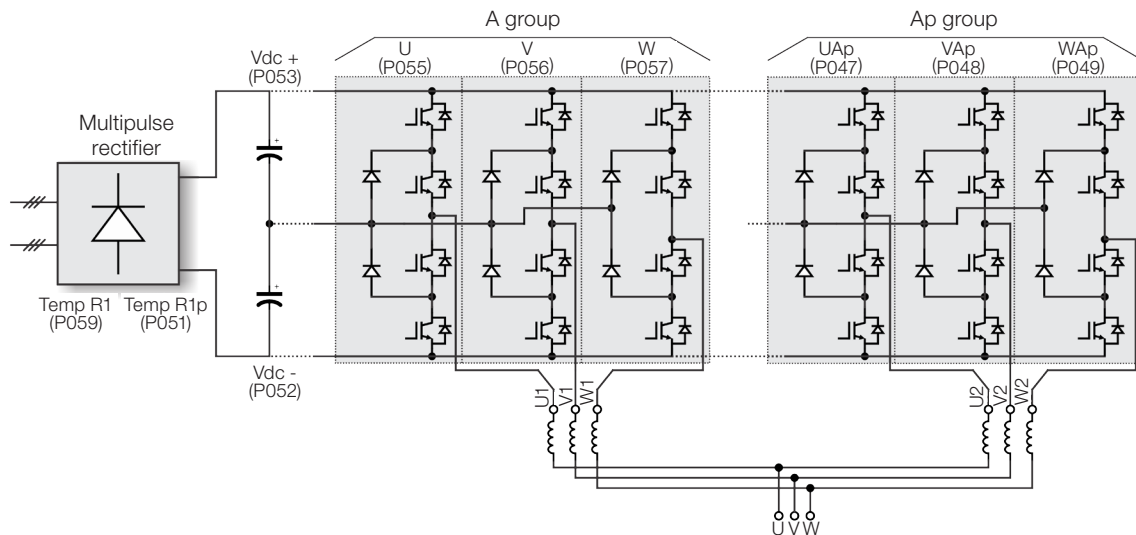

Figure 6.1: 3L2 line parameter correspondence

6.2 THREE LEVEL (3L) LINE WITH UP TO FOUR SET PARALLELISM (3L4)

For the present power section structure, up to 4 groups of power arms connected in parallel, by means of reactors, can be used. Table 6.1 presents the nomenclature used to identify the several power arms.

Table 6.1: Correspondence of the 4160 V line parameters with the power arms

Power Arm Identification		Correspondent Nomenclature	Arm Temperature Read-only Parameter
Group	Phase		
A	U	U	P055
	V	V	P056
	W	W	P057
Ap	U	UAp	P047
	V	VAp	P048
	W	WAp	P049
B	U	UB	P082
	V	VB	P083
	W	WB	P084
Bp	U	UBp	P085
	V	VBp	P086
	W	WBp	P087

The structure of the power groups operating in parallel is presented next.

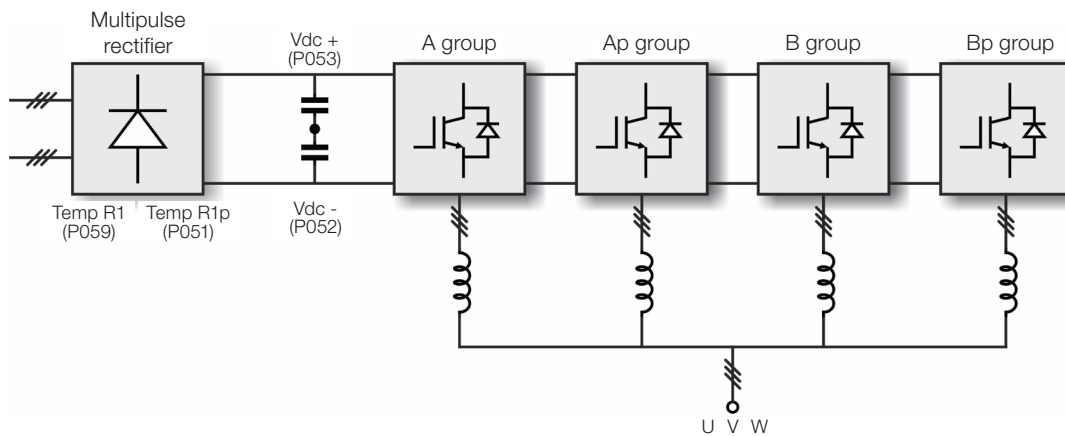

Figure 6.2: Power structure of the NPC 4160 V 3 levels up to 3L4

Table 6.2: Admissible power according to the number of groups used in parallel in the 3300 V and 4160 V line

Group	Frame Size	Maximum Power (CV)	Structure
A	A	2700	3L
A + Ap	C	5400	3L2
A + Ap + B	D	7750	3L3
A + Ap + B + Bp	E	10000	3L4

Configurations showed in the Table 6.1 on page 6-2 and power references of the Table 6.2 on page 6-2 are valid for the 3300 V and 4160 V lines. More information on the possible MVW-01 voltage and power configurations can be found in the product catalog.

6.3 PARALLELISM OF 2 FRAME D OR 2 FRAME E WITH MASTER/SLAVE RACK

The MVW-01 up to 22500 HP consists in the parallel association of two MVW-01 inverter sets of frame size D or E. The power structures are associated normally through the use of reactors and differ basically because of the use of two separated DC links fed by distinct secondary windings (or by using two completely independent transformers).

The main difference of this line compared to the other frame sizes that use parallelism is due to the use of two control sets of the size D or E, operating in slave mode and a master control rack managing the combined and synchronized operation of the slaves.

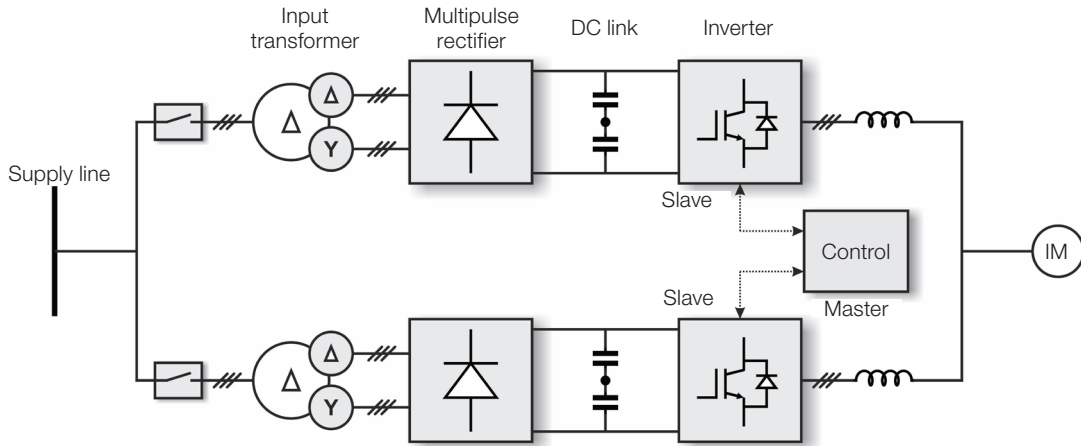

Figure 6.3: General diagram for the 2 x D and 2 x E models

This structure is necessary to increase the total number of inverter power arms, and in this system two inverters in parallel can be used, which, with the command of an auxiliary control rack equipped with specific software enables the operation of the system as a whole. The nomenclature regarding the power cell groups was maintained for each slave inverter, just like the parameters and the faults.

The control for the line up to 2 x E presents the need to use 3 HMIs, being one of them for the master rack whereas the two other present information regarding individual readings and faults of the slave racks. [Table 6.3 on page 6-3](#) lists the readings that are exhibited differently in the HMI of the master.

Table 6.3: Parameters exhibited differently in master and slave HMIs

Parameter	Slave HMI (standard)	Master HMI
P003	Inverter Current	Addition of the slave inverter currents
P004	DC Link Voltage	Highest voltage among the slave DC links



NOTE!

The created and changed parameters are presented in [Chapter 11 DETAILED PARAMETER DESCRIPTION on page 11-1](#), the same applies to faults and alarms, which are entirely described in [Chapter 14 DIAGNOSTICS AND TROUBLESHOOTING on page 14-1](#).

The connection between the master/slave commands can be performed according to the diagrams of [Figure 6.4 on page 6-3](#) or [Figure 6.5 on page 6-4](#).

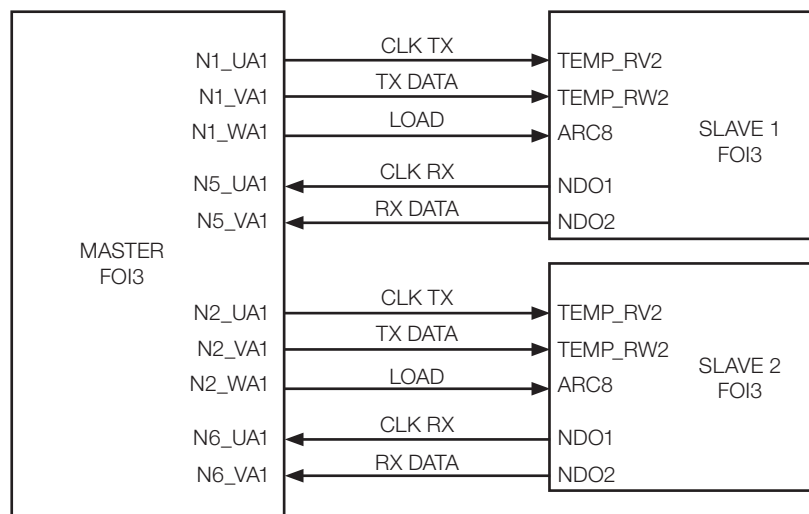

Figure 6.4: Communication between master and slave racks using FOI3

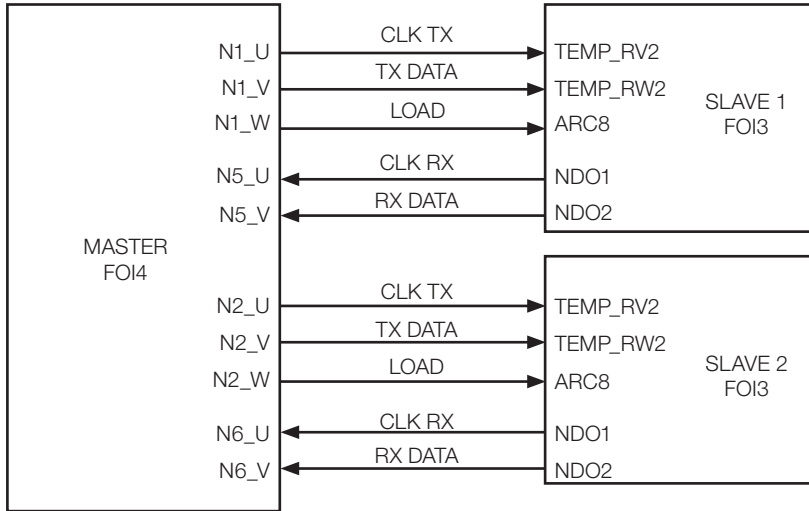

Figure 6.5: Communication between master and slave racks using FOI4



NOTE!

The connections are made with fiber optic cables, with a length limit of 10 m. More information on panel connections and mechanical dimensions can be found in the inverter electrical project.

6.4 FIVE LEVEL (5L) PARALLELISM LINE

6

For the higher power inverters of the 6.9 kV line, it is necessary the use of parallel H bridges per phase and, in the same way as for the 4160 V, the parallelism occurs by the use of reactors. Figure 6.6 on page 6-5 shows the detailed description of the H bridge topology, as well as the related parameters.

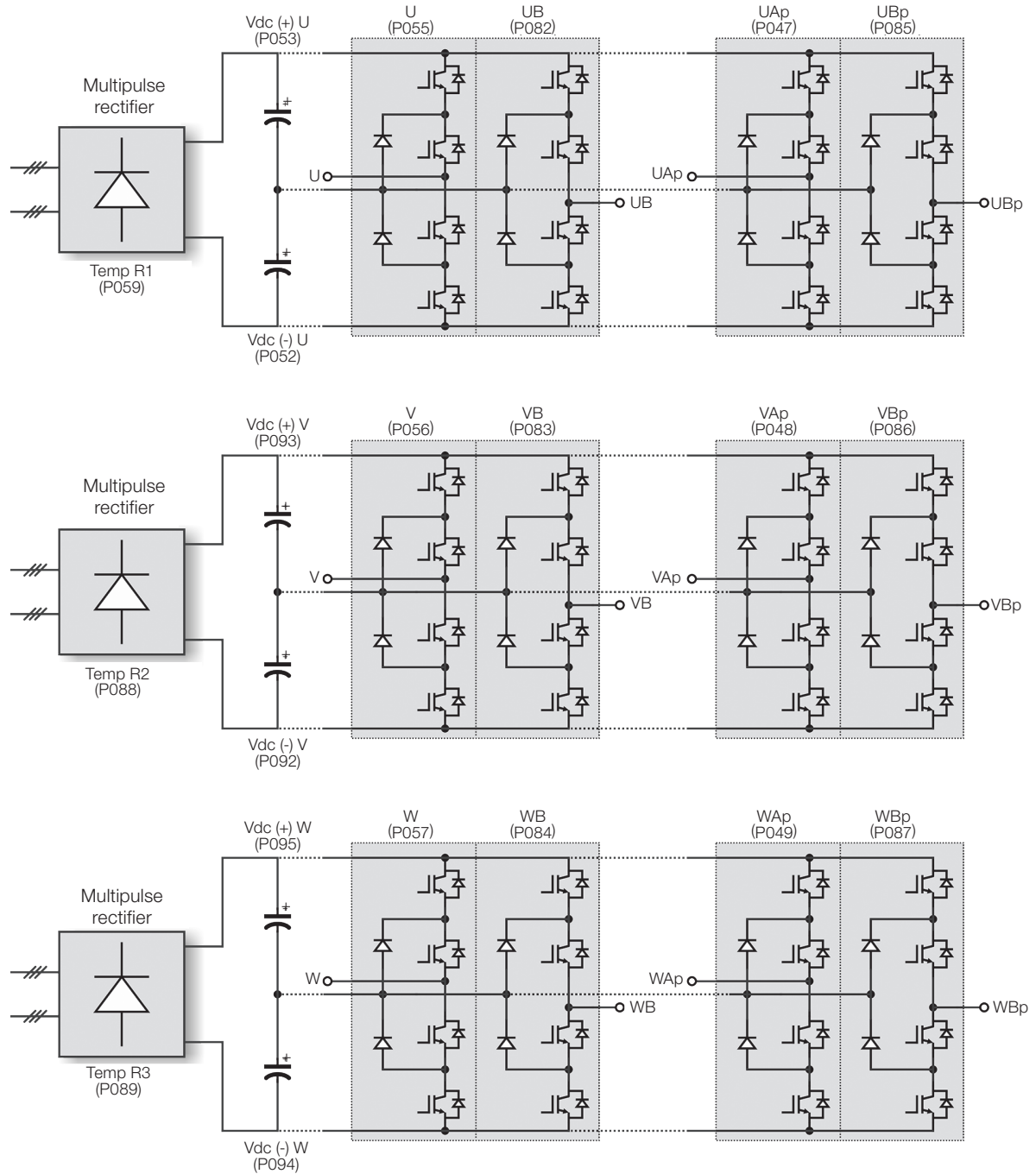

Figure 6.6: Topology of the 6.9 kV line 5 levels parallel

The parallelism reactors are magnetically coupled, as shown in the next figure.

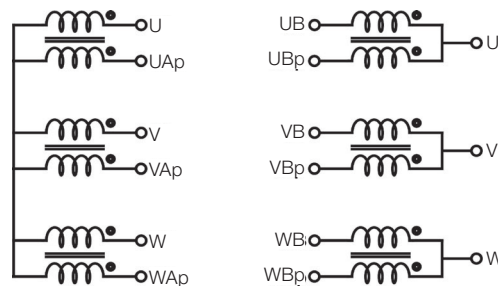

Figure 6.7: Parallelism reactors connection of the 6.9 kV line

The other mechanical and power options of the 6.9 kV line can be found in the product catalog.

The parameters and faults correspondent to the power structure of this line are described in [Chapter 11 DETAILED PARAMETER DESCRIPTION](#) on page 11-1 and [Chapter 14 DIAGNOSTICS AND TROUBLESHOOTING](#) on page 14-1.

7 SYNCHRONOUS MOTOR LINE

In order to allow driving synchronous motors, the MVW-01 introduces a number of software functions and new hardware elements for commanding and controlling these motors.

Figure 7.1 on page 7-1 presents the general diagram for driving the synchronous motor using the MVW-01. For more details on the Excitation Control System and the direct connection of the motor to the line, refer to the electrical project of the inverter.

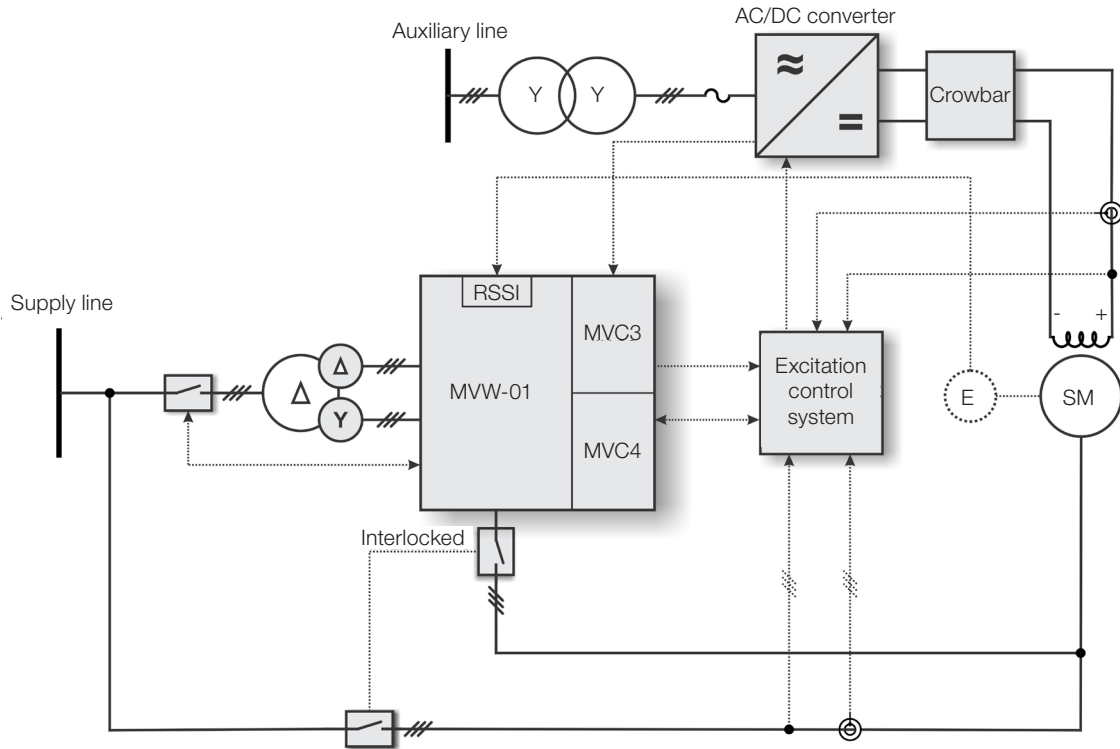

Figure 7.1: General diagram of the inverter for synchronous motor

7.1 ABSOLUTE ENCODER WITH RSSI BOARD

In the application of driving synchronous machines, it is necessary to make sure that the inverter has the exact position of the rotor regarding the stator and, since the incremental encoder is not capable of supplying this information, the use of an absolute encoder becomes necessary.

7.1.1 Absolute Encoder

The synchronous motor control requires the use of an absolute encoder, which must follow the following specifications:

Synchronous Serial Interface (SSI) communication protocol with RS-485 communication channel, with clock and 16 bit word size in the following format:

- 14 data bits
- 1 ZERO bit
- 1 even parity bit

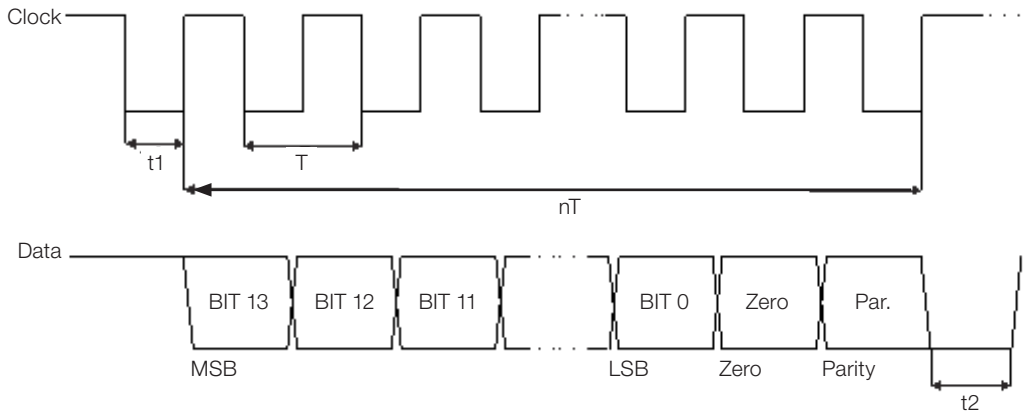

Figure 7.2: Clock specification and data transfer for the absolute encoder

Supply voltage of 15 V, with consumption lower than 300 mA;

Resolution of 14 bits per turn, which ensures a dynamic equivalent to the conventional incremental encoder;

When mounting the encoder next to the motor, it is recommended:

Coupling the encoder directly to the motor shaft (using a flexible coupling, however without torsional flexibility);

Both the shaft and the metallic frame of the encoder must be electrically isolated from the motor (minimum distance of 3 mm);

Use good quality flexible couplings that prevent mechanical oscillations or "backlash".



NOTE!

The standard absolute encoder recommended for the MVW-01 is the Baumer MHAP 400 B5 XXXXSB14EZ D.

The maximum encoder cable length is 120 m.

Refer to the motor project to define the type of encoder mounting.

7

7.1.2 RSSI Board

The use of absolute encoder implies the need for an SSI data interface (Synchronous Serial Interface) between the encoder and the inverter. The RSSI board was developed for the encoder specification previously described. This board has the following features:

Supply voltage of 24 V DC, with consumption of up to 700 mA;

RS485 communication channel for data transmission and clock according to SSI standard with absolute encoder;

2 fiber optic communication channels for use with up to two boards, MVC3 control and FOI3.

Use shielded cable for the electrical connection, keeping it as far as possible (> 25 cm) from the other wiring (power, control, etc.). Preferably, inside a metallic conduit.

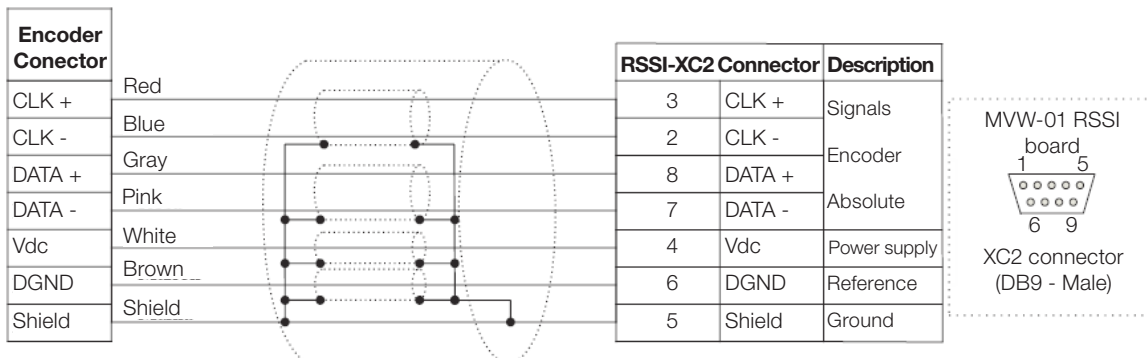

Figure 7.3: RSSI - Encoder connection cable

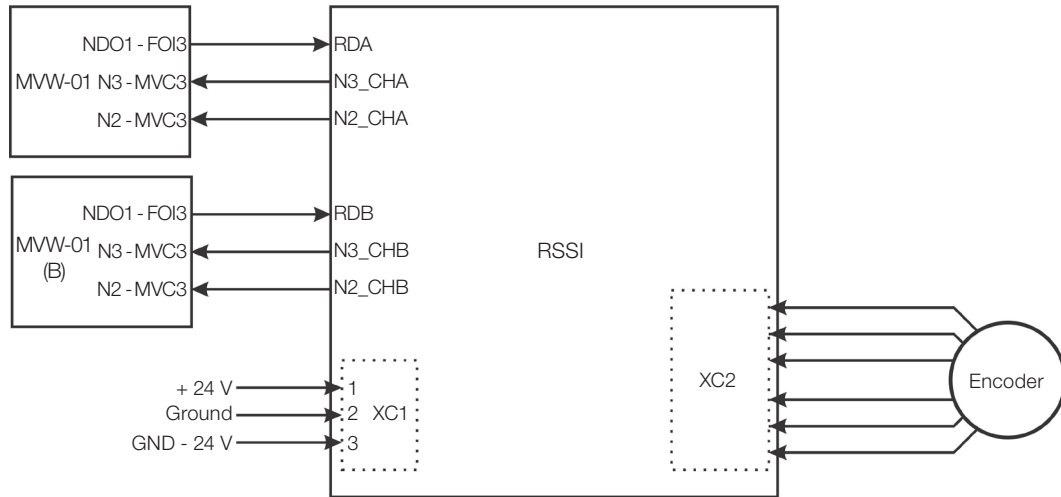

Figure 7.4: Diagram of the connection with MVC3 and FOI3 boards

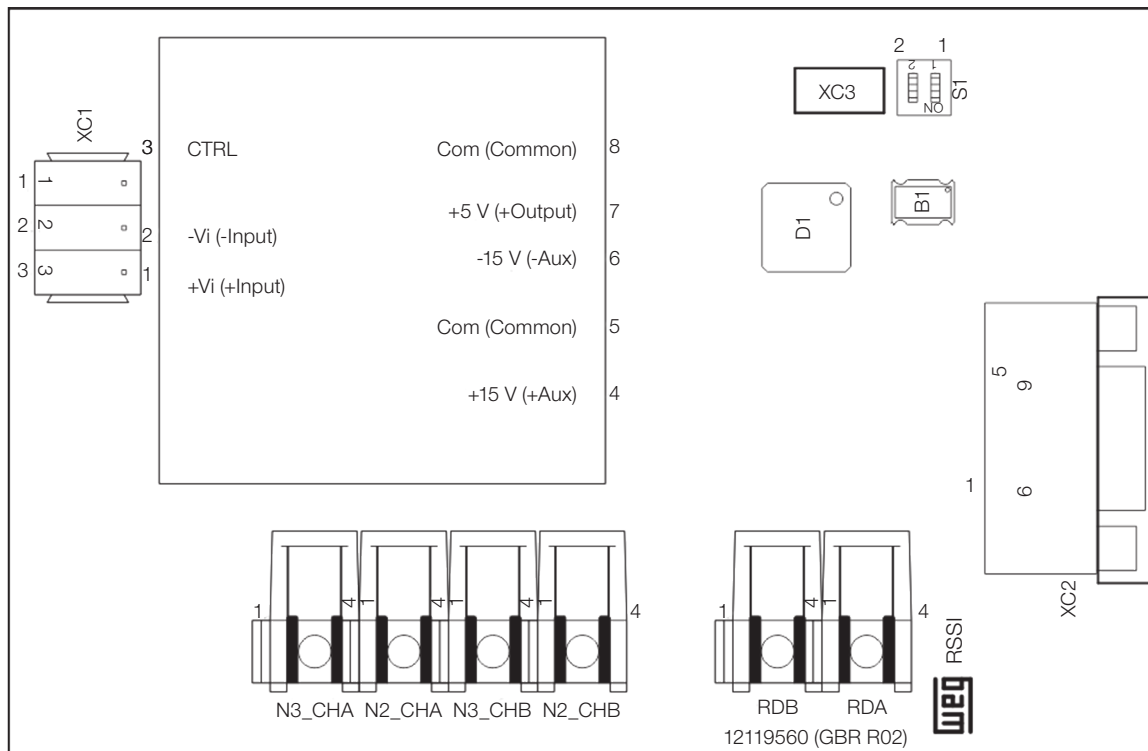

Figure 7.5: RSSI board

7.2 FIELD EXCITATION SET (DC WITH BRUSHES)

The field excitation of the synchronous motor can be done through an AC-DC converter that presents the possibility of being controlled by a control loop, and that has an input for current reference and presents an analogue output with the information of its output current (feedback for the MVW-01).

Specifications:

Current reference input AC-DC: 0 V to 10 V (AC-DC 5 V = 1 PU, observe P462);

Feedback of the output current for the MVW-01: 0 V to 10 V (MVW-01 5 V = 1 PU, observe P462 and P744).



NOTE!

The MVC3 board has only voltage signals, in order to use current signals an external current transducer must be used.

An example of how to program the inverter to configure the field current reference is shown in [Figure 7.6 on page 7-4](#), and the parameters mentioned in the image are described in [Chapter 11 DETAILED PARAMETER DESCRIPTION on page 11-1](#).

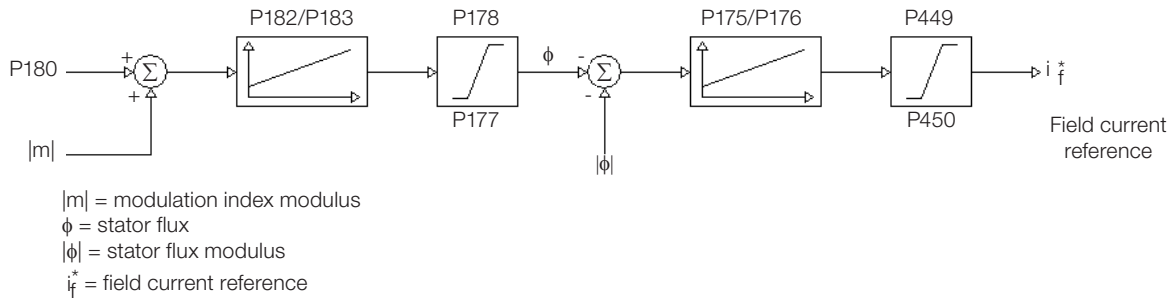

Figure 7.6: Parameters used by the inverter in the calculation of the of the field current reference



NOTE!

Information presented in [Chapter 7 SYNCHRONOUS MOTOR LINE on page 7-1](#) of this manual refers to the operation of synchronous machines with DC excitation and with brushes. In order to drive synchronous machines with other types of excitation, consult WEG.

8 INSTALLATION, CONNECTION AND ENERGIZATION

This chapter describes the electrical and mechanical installation procedures for the MVW-01. The presented guidance and suggestions must be followed in order to assure the proper inverter operation.



ATTENTION!

- The handling of the MVW-01 and its mechanical and electrical installation must be carried out by persons trained and qualified by WEG.

STORAGE OF THE MVW-01 PANEL AND ARMS:

- After receiving the equipment, remove the plastic film in order to prevent moisture condensation.
- Do not store exposed to sunshine and to temperatures above 40 °C (104 °F).
- Store the equipment in a clean, protected place with relative humidity not higher than 80 %.
- During all the storage period the conditions mentioned earlier must be satisfied, but when components are stored for more than one year, measures must be taken to dehumidify the storage location.
- When using equipment after a long storage period, verify whether the equipment is free of scratches, dirt, rust and other damages.
- The inverter performance and reliability can be impaired if the inverter or the power arms were stored in an environment out of the conditions listed previously.



DANGER!

- The procedures recommended in this warning have the purpose of protecting the user from death, severe personal injury and considerable property damage.
- Power supply isolating switches: equipment for isolating the inverter power and auxiliary supplies must be planned. They must cut off the inverter supplies (e.g., during installation maintenance tasks).
- This equipment cannot be used as emergency stop mechanism.
- Make sure that the power supply is disconnected before starting the wiring.
- The following information is intended to be a guide for a proper installation. Comply with applicable local regulations for electrical installations.



DANGER!

- Les procédures recommandées dans cet avertissement visent à protéger l'utilisateur de la mort, de blessures graves et de dégâts matériels importants.
- Interrupteurs d'isolement de l'alimentation : Le matériel d'isolement de l'alimentation de l'onduleur et des alimentations auxiliaires doit être prévu. Il doit couper les alimentations de l'onduleur (par ex.: pendant les tâches de maintenance de l'installation).
- Cet équipement ne doit pas être utilisé comme mécanisme d'arrêt d'urgence.
- Vérifiez que l'alimentation est débranchée avant de commencer le câblage.
- Les informations suivantes ont pour but de servir de guide pour une bonne installation. Respectez la réglementation locale applicable sur les installations électriques.

8.1 MECHANICAL INSTALLATION

8.1.1 Environmental Conditions

The inverter installation location is an important factor to assure good performance and high product reliability. The inverter must be installed in an environment free of:

- Direct exposure to sunlight, rain, high humidity, or sea-air.
- Inflammable or corrosive gases or liquids.
- Excessive vibration, dust or metallic particles and oil mist.

Allowed environmental conditions:

- Temperature: From 0 °C to 40 °C (32 °F to 140 °F) - nominal conditions (no derating required).
- From 40 °C to 50 °C (140 °F to 122 °F): current reduction of 2.5 % for each Celsius degree above 40 °C (140 °F).
- Relative humidity: from 5 % to 90 % non-condensing.
- Altitude: up to 1000 m (3.300 ft) - nominal conditions (no derating required).
- From 1000 m to 4000 m (3,300 ft to 13.200 ft) - current derating of 1 % each 100 m (or 0.3 % each 100 ft) above 1000 m (3.300 ft) altitude.
- Pollution degree: 2 (according to IEC/UL standards) with non-conductive pollution.
- Condensation shall not originate conduction through the accumulated residues.

The medium voltage inverter MVW-01 is supplied in form of a panel, whose dimensions are presented in [Table 3.1 on page 3-3](#). According to the components mounted in each column and to their function, this complete panel results in the inseparable union of three functions, rectifier, inverter and control.

The inverter power arms are supplied separately in their own packing.

Arm dimensions: 360 mm x 1040 mm x 680 mm (width x height x depth).

8.1.2 Handling Recommendations

The inverter package must be removed only at the installation site, where the panel will be operated. Before hoisting or moving the panel, locate the hoisting eyes and fragile spots in the documentation that comes with the product. Follow the instructions that come with the panel.

8.1.3 Hoisting

Make sure that the lifting device used to hoist the panel and the arms is suitable for their weight and shape, refer to the [Table 8.1 on page 8-2](#).

Table 8.1: Panel weight (approximately)

Frame Size	Weight kg (lb)
A0	900
A	1560
B	1700
C	2700
D	4500
E	5000
2 x D	2 x 4500
2 x E	2 x 5000

The inverter arms weigh approximately 140 kg (308.6 lb) each arms.

Observe the gravity center and ensure that the hoisting mechanism is adequate and safe. Use the configuration showed in the [Figure 8.1 on page 8-3](#).

The cables or chains used for hoisting must be at a minimum angle of 45° regarding the horizontal plane.

Hoisting must be done in a slow and stable manner. Before starting make sure the entire pass is clear of obstacles. If any alteration or damage in the panel structure is noticed, then abort the hoisting and rearrange the cables or chains.

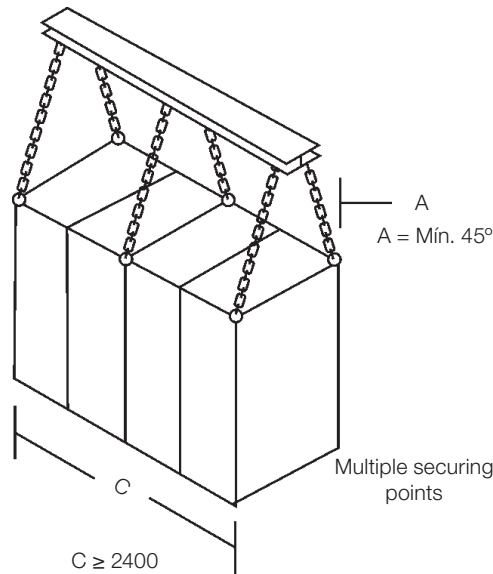

Figure 8.1: Recommended hoisting mechanism for the panel movement

8.1.4 Moving

When cranes or pulleys are used, make sure that the movements are slow and smooth, so that the panel and the arms do not suffer excessive swings and vibration.

When using movable hydraulic jacks, forklifts, rollers or other means, distribute the support points from one extreme through the other, avoiding pressure on fragile areas.

Make sure that all the panel doors be closed and locked, and that the door handles be in protected position.

8.1.5 Unpacking

Use proper tools to unpack the MVW-01 panel and its arms. During this process, make sure that all the items listed in the documentation that comes with the product are present and in perfect conditions. Contact your local WEG representative in case of any irregularity.

Remove the arm packages carefully. The arms have hoisting eyes.

The inverter arms have fragile components (electronic boards, fiber optic connectors, busbars, wiring, etc.). Avoid touching these components! The arms must always be handled through their external metallic frame. While opening the package, inspect the arms for transportation damage. Do not install the arms if they are damaged or if you suspect of any damage.

Remove all packing material (plastic, wood, polystyrene foam, metal, nails, bolts, nuts, etc.) that might have remained inside the inverter panel or in the arms.



ATTENTION!

If any component presents problems (damages) it is recommended to:

- Stop the unpacking immediately.
- Contact the carrier and formally fill in a complaint with the problem found.
- Take pictures of the damaged parts.
- Contact your WEG representative or service.

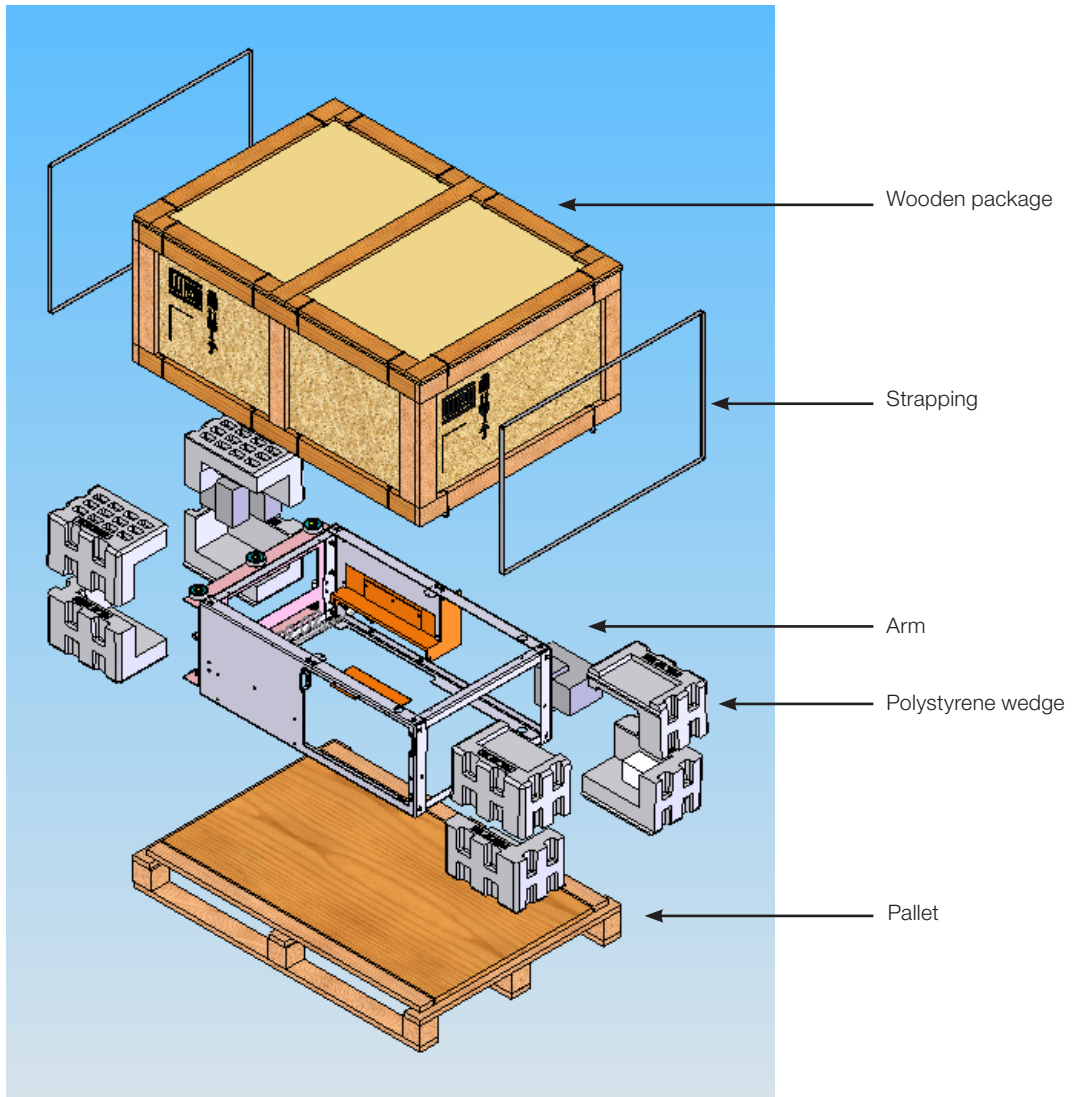

8

Figure 8.2: Standard power arm with package

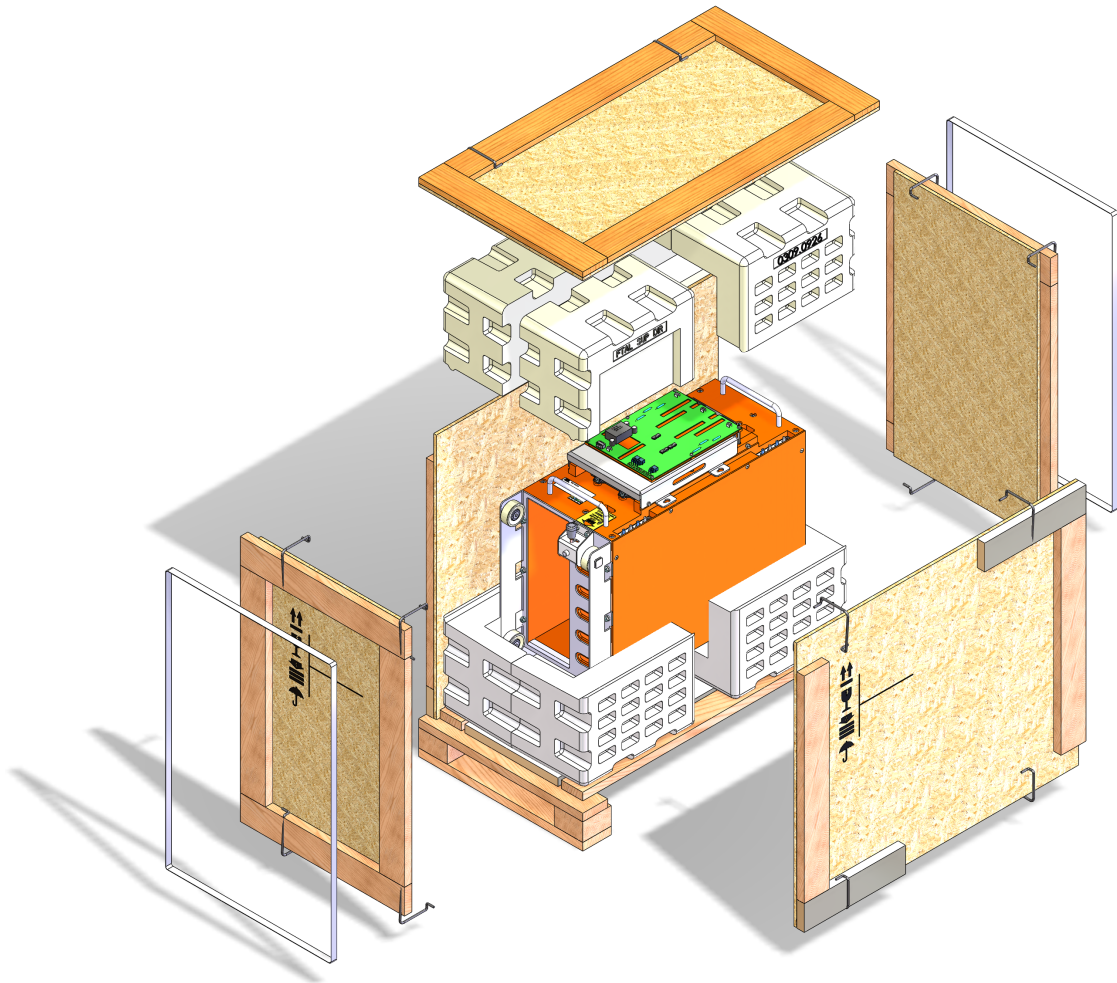

Figure 8.3: Compact power arm with package

8.1.6 Positioning/Mounting

The MVW-01 panel must be placed on a flat leveled surface, thus avoiding mechanical instability, door misalignment, among other problems.

The permanent operation position must allow heat radiation from all the surfaces and the necessary ventilation for its operation. The area in front of the panel must remain unobstructed, so that a total opening of the doors be possible, as well as the insertion and extraction of the arms and/or the power and control cables.

The [Table 3.1 on page 3-3](#) shows the panel dimensions.



ATTENTION!

Make sure there is access for the electric connections: Input cables at the rectifier column and the output for the motor, main circuit breaker commands and status, transformer and motor protections, analog and digital inputs and outputs.

- Notes:** (1) Extracted from the WEG TBG-269a standard.
 (2) Orientative instructions. Refer to the customer's specific project.
 (3) Panel securing points at the base.

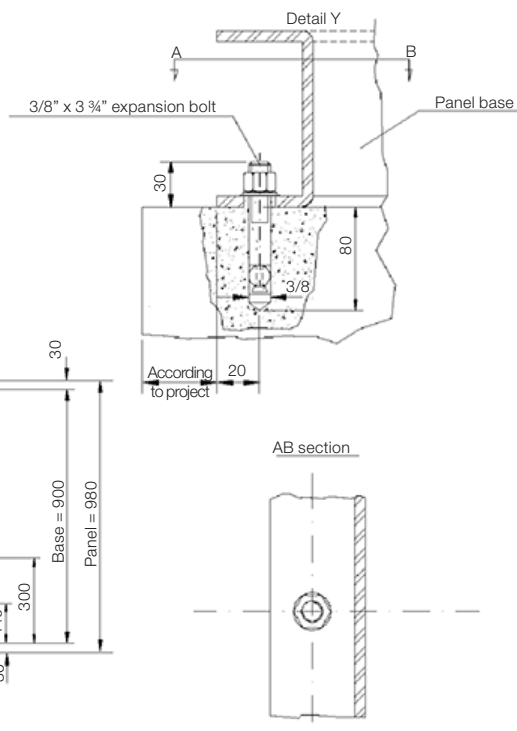
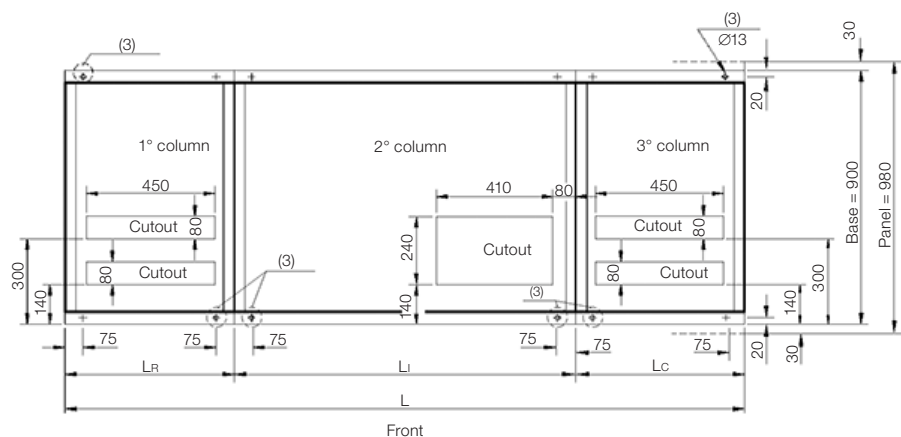

Figure 8.4: Anchoring the MVW-01 panel to the floor



NOTE!

Recommendations for anchoring the panel may vary for the several MVW-01 models. For more information refer to the specific project documentation.

8.1.7 Power Arm Insertion

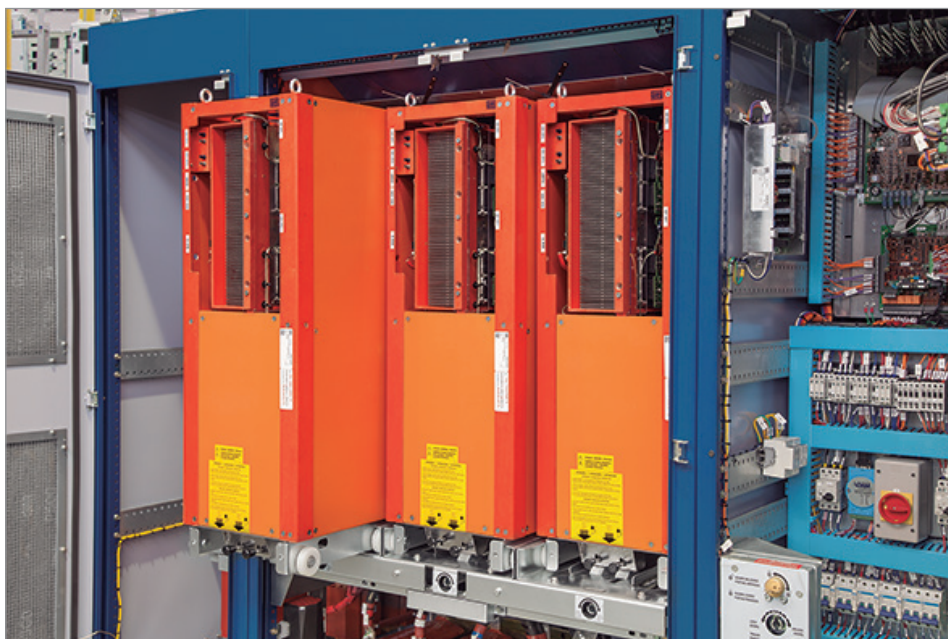

Figure 8.5: Power Arm

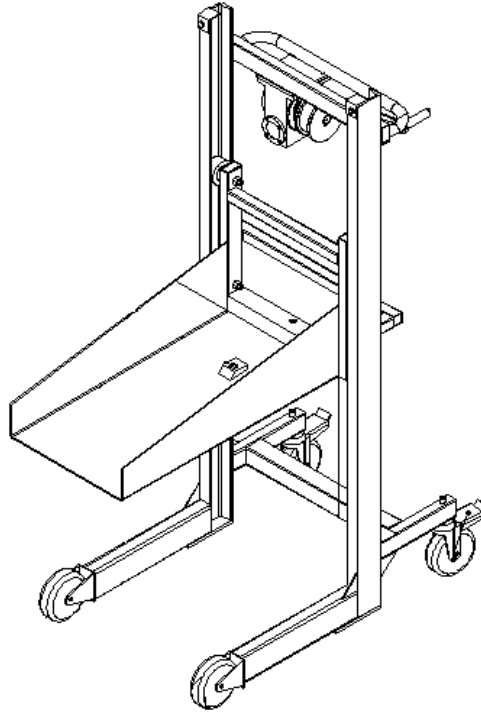

Figure 8.6: Power arm insertion/extraction/movement trolley

The power arm insertion must be performed with the help of the transport trolley (WEG part number 11136572), as shown in [Figure 8.6 on page 8-7](#) and according to the following procedure.



NOTE!

During the power arm transport, they must have the locking mechanism active and be transported close to the floor ([Figure 8.7 on page 8-8](#) - picture 1).

1. Rotate the crank handle until the trolley reaches the floor level.
2. Push the arm onto the trolley rails and activate the locking mechanism.
3. Move the transport trolley close to the panel, lifting the power arm to the required height and insert the trolley tabs at the position shown in [Figure 8.7 on page 8-8](#) - pictures 1, 2 and 3.
4. Lock the trolley wheels.
5. Release the lock that secures the arm to the trolley ([Figure 8.7 on page 8-8](#) - picture 4) and push it observing the alignment of the wheels with the base in the panel.
6. The arm must be manually inserted until the locking system (locking pin) is activated ([Figure 8.7 on page 8-8](#) - picture 5).
7. The final insertion stage is done using a crank handle, continuing the insertion to the point the second locking pin engages ([Figure 8.7 on page 8-8](#) - pictures 5 and 6).

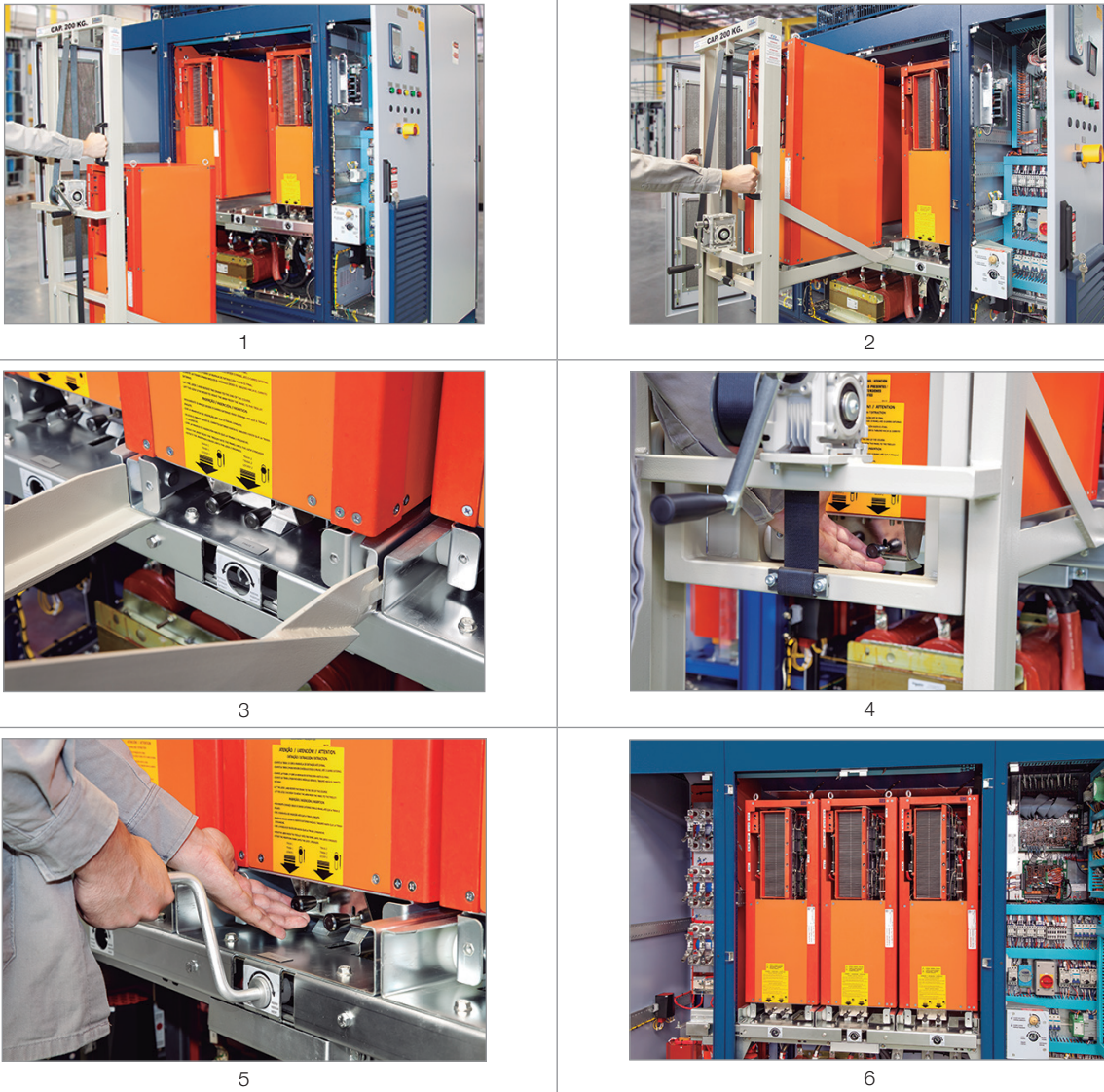

Figure 8.7: Details of the arm insertion stages

8.1.8 Power Arm Electric and Fiber Optic Connections

After inserting the power arms (U, V and W phases) connect the fiber optic cables and the supply cables according to the labels presented on the arms and on the cables.

The identifications of the cables are presented in the [Table 8.2 on page 8-8](#) and [Table 8.3 on page 8-9](#).

Table 8.2: Fiber optic cables identification

	Identification on the Fiber Optic Cable	Identification on the Arm
1	GS1x-N1-FOI x	GS1
2	GS2x-N2-FOI x	GS2
3	GS3x-N3-FOI x	GS3
4	GS4x-N4-FOI x	GS4
5	VST1x-N5-FOI x	VST1
6	VST2x-N6-FOI x	VST2
7	VST3x-N7-FOI x	VST3
8	VST4x-N8-FOI x	VST4
9	TEMPx-N9-FOI x	TEMP
10	OSAx-N10-FOI x	OSA
11	OSBx-N11-FOI x	OSB

Table 8.3: Power arms supply cables identification

	Identification on the Arm Supply Cable	Identification on the Arm
1	BIX	XC1

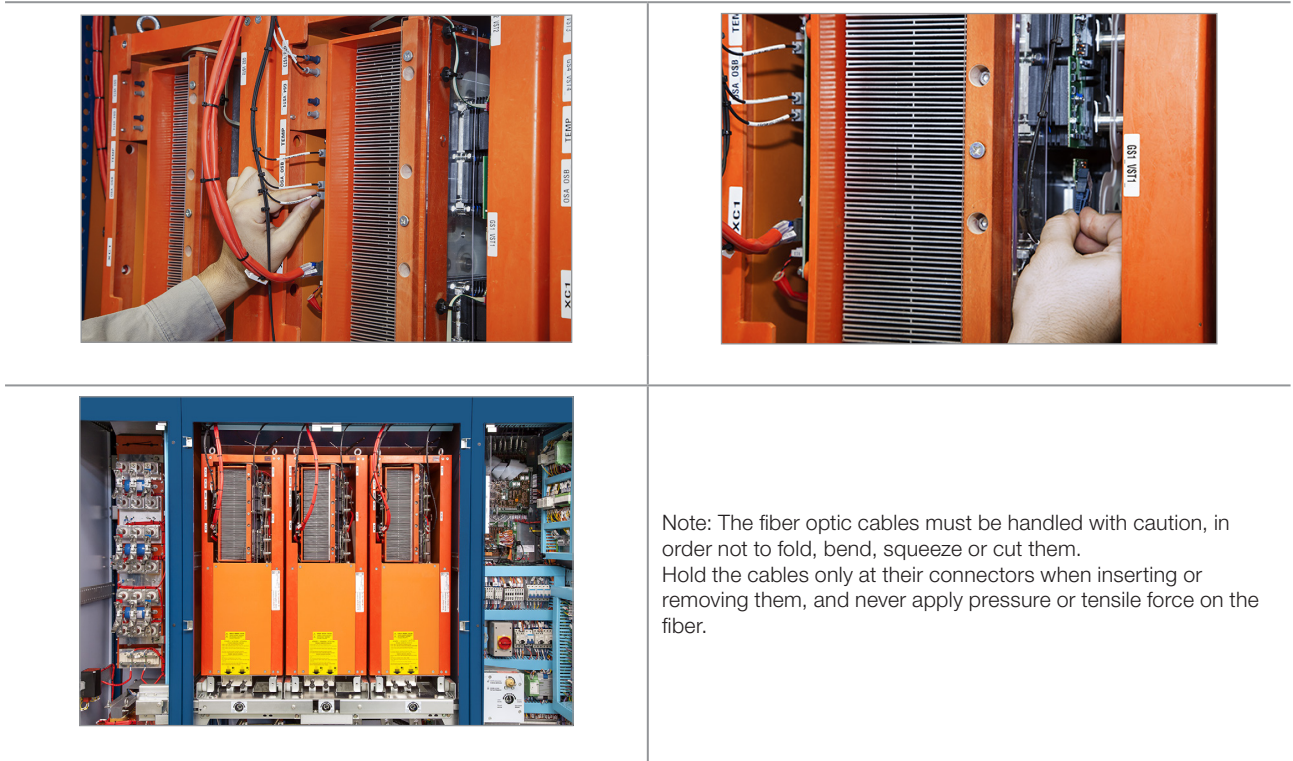

Figure 8.8: Details of the power arm supply and fiber optic cables installation stages

NOTE!
In order to extract the power arms follow the procedures described in the previous sections in reverse order.

8.1.9 Insertion of the MVW-01C Power Arms

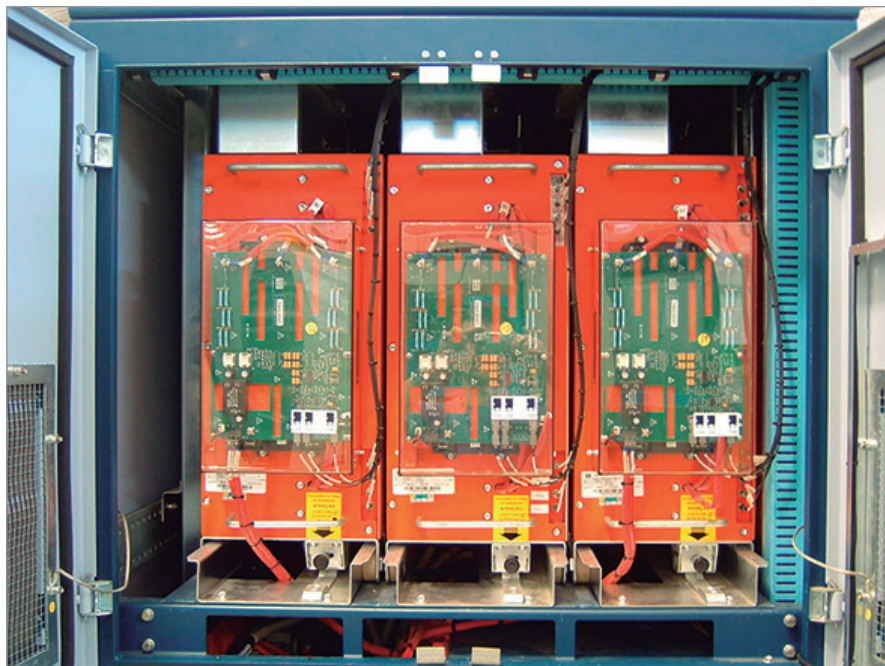

Figure 8.9: Power arms inserted in the MVW-01C



The power arm insertion must be performed with the help of the transport trolley (WEG part number 11136572), and according to the following procedure.



NOTE!

During the power arm transport, they must have the locking mechanism engaged.

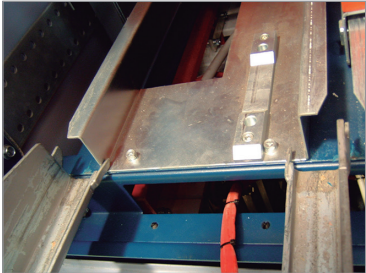
Table 8.4: Description of the power arm insertion procedure

Picture	Insertion Procedure
	<ol style="list-style-type: none"> 1. Place the power arm on the transport trolley observing the proper locking with the locking pin. 2. Lift the arm to the necessary height and bring the trolley close to the panel.
	<ol style="list-style-type: none"> 3. Align the trolley guides with the inverter base according to the picture 2. 4. Pay attention to the ISOX board supply cable, which cannot be on the insertion base in the panel at the moment of the arm insertion. 5. Lock the trolley wheels.
	<ol style="list-style-type: none"> 6. Release the lock that secures the arm to the trolley according to the picture 3.

	Picture	Insertion Procedure
4		<p>7. Holding on both power arm handles, push it observing the alignment of the wheels with the base in the panel.</p>
5		<p>8. The arms must be inserted to the point that the locking pin engages. Observe the label about the insertion end, as shown in picture 5.</p>
6		<p>9. The power arm insertion procedure is complete.</p>



NOTE!

In order to extract the power arms follow the procedures described in the previous sections in reverse order.

Table 8.5: Procedure for the installation of power supply and fiber optic cables on the power arms

	Picture	Connection Procedure
1		<p>1. Connect the gate (GS1, GS2, GS3 and GS4) and status (VST1, VST2, VST3 and VST4) fiber optic cables according to the picture 1.</p> <p>Note: The fiber optic cables must be handled with caution, in order not to crumple, bend, crush or cut them. Apply force only on the connectors and never on the cable while inserting or removing the fiber optic cables.</p>
2		<p>2. In order to connect the ISOX fiber optic cables and the power supply cable, it is necessary to remove the protective acrylic cover.</p> <p>3. Connect the optic fibers OSA, OSB, and TEMP, and the power supply cable XC1, according to the picture 2.</p>
3		<p>4. Reinstall the protective acrylic cover.</p> <p>5. The installation of the power supply cable and fiber optic cables is complete.</p>

8.2 ELECTRICAL INSTALLATION

8.2.1 Power Section

The power cables that connect the supply line to the main circuit breaker and the circuit breaker to the input transformer primary must be sized for the specified voltage and current. Refer to the cubicle (main circuit breaker) and transformer documentation, strictly following all the recommendations.

The power cables that connect the input, transformer secondary windings to the MVW-01 rectifier column and

those that connect the inverter column to the medium voltage motor (Figure 8.10 on page 8-14) must be specified for medium voltage application and sized for the nominal currents.

Table 8.6: Recommended power cables cross section (copper) [AWG]

	Power Cables [mm ²]: U, V, W, VAS, VBS, VCS, VAD, VBD, VCD	Maximum Current [A]
Single Cable	10	71
	16	96
	25	126
	35	157
	50	189
	70	241
	95	292
	120	337
	150	384
	185	438
Two Cables	240	514
	2x50 *	302
	2x70 *	386
	2x95 *	467
	2x120 *	539
	2x150 *	614
	2x185 *	701
Three Cables	2x240 *	822
	3x95 *	613
	3x120 *	708
	3x150 *	806
	3x185 *	920
Four	3x240 *	1079
	4x120 *	876
	4x150 *	998
	4x185 *	1139
Five	4x240 *	1336
	5x185 *	1314
	5x240 *	1542

* It is recommended that the connection of parallel cables be made with auxiliary busbars.

Table 8.7: Recommended power cables cross section (copper) [AWG]

Gauge of the Power Cables (S cross section) [mm ²]	Minimum Gauge of the Grounding Cables (S cross section) (PE) [mm ²]
S ≤ 16	S
16 < S ≤ 35	16
35 < S	S / 2



NOTE!

The cable cross sections/gauges presented in the Table 8.7 on page 8-13 are only orientative. In order to size the cables correctly the installation conditions, the applicable standards and regulations, and the maximum allowed voltage drop must be considered.

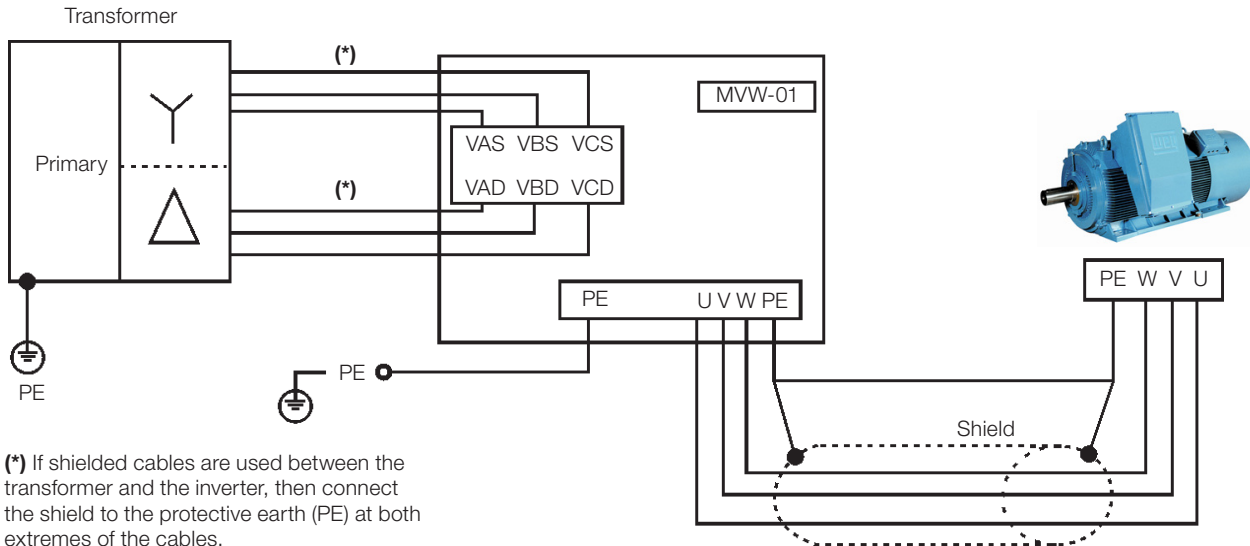

Figure 8.10: Power and ground connections

- Minimum cable insulation voltage:

Table 8.8: Minimum insulation voltage of the power cables

Rated Voltage [kV]	Minimum Insulation Voltage [kV]
2.3	3.6/6
3.3 and 4.16	6/10
6.9	8.7/15

Commercial examples:

- Belden: 37540.
- Cofiban: Cofialt 7 kV (without shield).
- Pirelli: Eprotenax 6/10 kV.
- Ficap: Fibep or EPDry 6/10 kV.
- Use proper terminations for the power connections as well as for the shield connections to the ground bar.
- Tighten the connections with the appropriate torque.

Table 8.9: Power connections cable lugs and tightening torque

Identification	Column	Cable Lug	Torque [Nm] ±20 %
VAD	Rectifier	M10	30
VBD			
VCD			
VAS			
VBS			
VCS			
U	Inverter	M12	60
V			
W			
PE			
Shields	Rectifier and Inverter	M8	15



DANGER!

- It is mandatory to connect the inverter to a protection ground (PE). The grounding connection must follow the local regulations. Use at least conductors with the wire gauge indicated in the [Table 8.7 on page 8-13](#). Connect the inverter to a specific grounding rod or to the general ground system (resistance ≤ 10 Ohms), the transformer frame ground for instance.
- Never connect the input transformer secondary windings to the ground.



DANGER!

- Il est obligatoire de connecter l'onduleur à un connecteur de mise à la terre (PE). La connexion de mise à la terre doit suivre les réglementations locales. Utilisez au moins des conducteurs avec le calibre de fil indiqué dans le [Table 8.7 on page 8-13](#). Connectez l'onduleur à une tige de mise à la terre spécifique ou au système de mise à la terre général (résistance ≤ 10 ohms), la terre du cadre du transformateur par exemple.
- Ne connectez jamais les enroulements secondaires du transformateur d'entrée à la terre.

8.2.2 Input Circuit Breaker

The MVW-01 operates the input circuit breaker. This circuit breaker must have minimum voltage, closing and opening coils. The power supply for the circuit breaker circuits comes from the MVW-01. The following signals, provided by the circuit breaker, are necessary for its operation: Ready, On, Off and Trip. These signals must be dry contacts (potential free).

The MVW-01 also has inputs for the indications of input transformer alarm and fault.

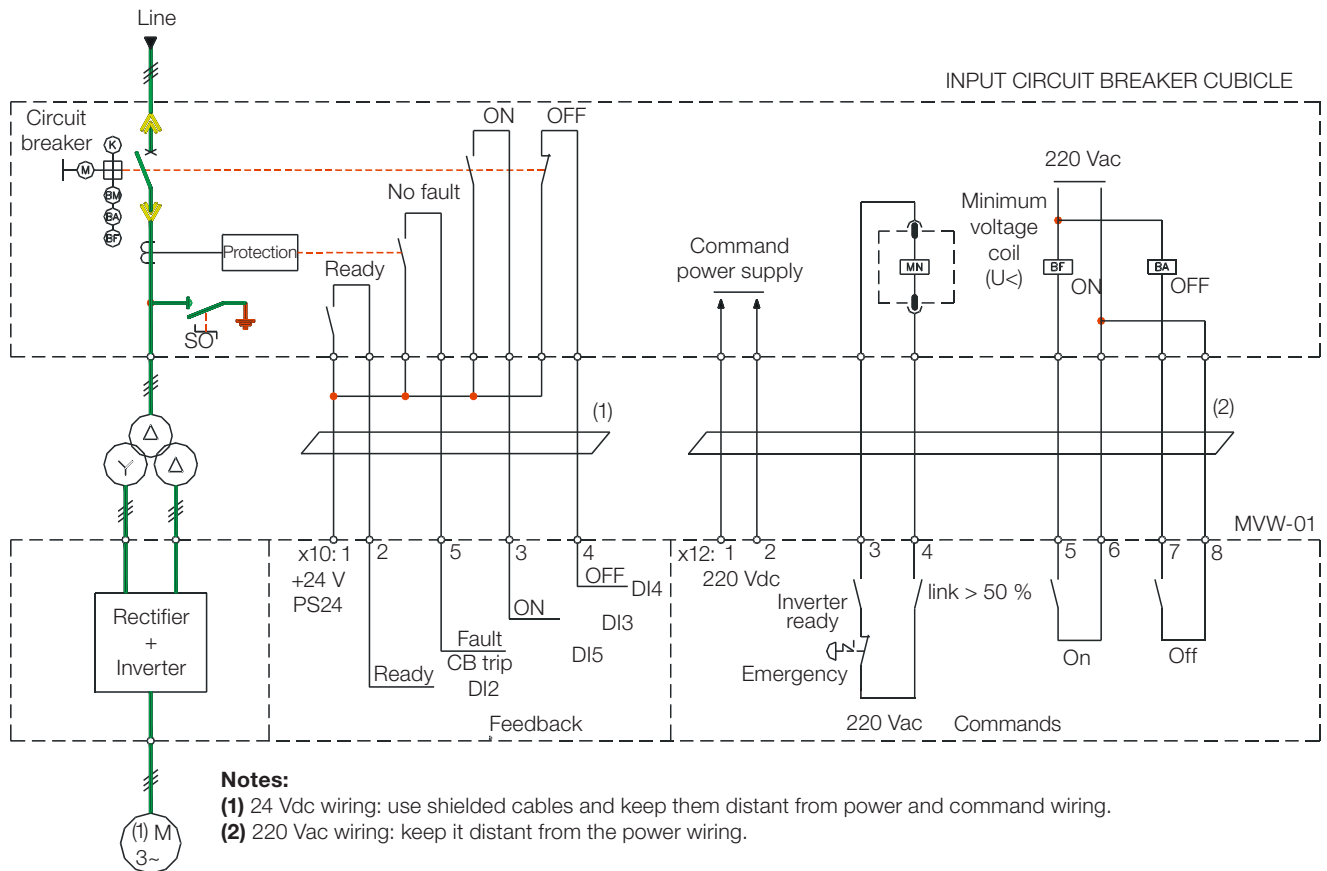

Figure 8.11: Connections between the input circuit breaker and the inverter



ATTENTION!

The input circuit breaker must only be closed by the inverter, otherwise the transformer and the inverter may be damaged.



DANGER!

Although the inverter commands the opening of the circuit breaker, there is no guarantee of its opening. In order to open the medium voltage cabinets for maintenance, follow all the procedures of safe de-energization (refer to the [Item 8.3.4 Safe De-energization Instructions on page 8-19](#)).



DANGER!

Bien que l'onduleur commande l'ouverture du coupe-circuit, il n'y a pas de garantie qu'il s'ouvre. Afin d'ouvrir les armoires moyenne tension pour la maintenance, suivez toutes les procédures de mise hors tension (élément [Item 8.3.4 Safe De-energization Instructions on page 8-19](#)).



NOTE!

It is recommended that the MVW-01 Kirk key is interlocked with the ring welded to the key of the input cubicle.

MVW-01C ELECTRICAL INSTALLATION

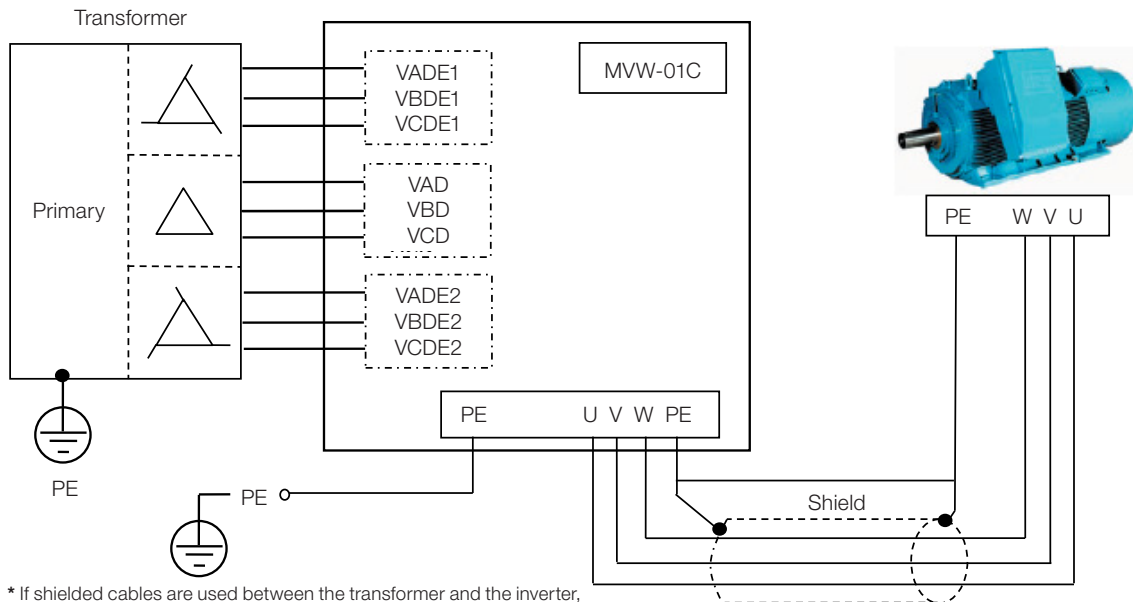

* If shielded cables are used between the transformer and the inverter, then connect the shield to the protective earth (PE) at both extremes of the cables.

Figure 8.12: Power and ground connections

Table 8.10: Power connections cable lugs and tightening torque

Identification	Column	Cable Lug	Torque [Nm] ± 20 %
VADE1, VBDE1 and VCDE1	Rectifier	M10	30
VAD, VBD and VCD	Rectifier	M10	
VADE2, VBDE2 and VCDE2	Rectifier	M10	
U	Rectifier	M12	60
V	Rectifier		
W	Rectifier		
PE	Rectifier	M12	15
Shields	Rectifier	M8	

8.2.3 Low Voltage Auxiliary Supply

Control column power supply nominal voltage selection

An auxiliary voltage supply (220 V-480 V) should be available in the installation. This voltage must be wired to the terminal strip present in the control column. The command transformer (T1) taps must be selected according to the available auxiliary voltage. For more details, refer to the MVW-01 electrical project.

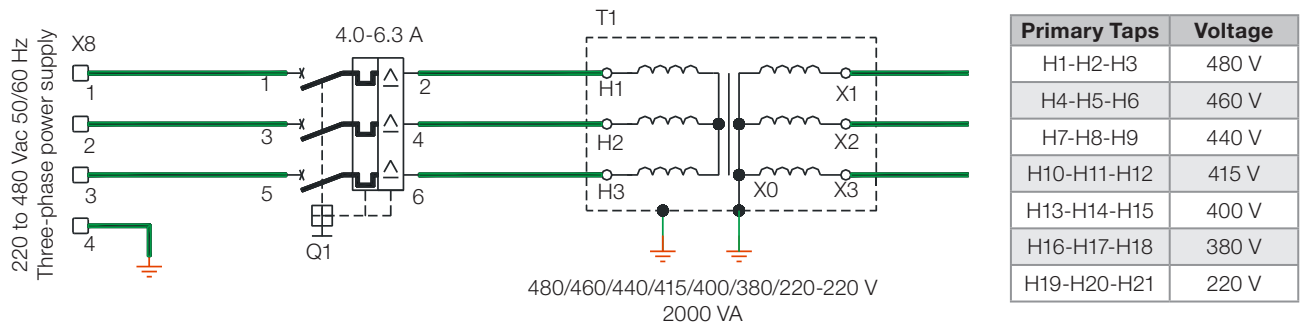

Figure 8.13: Auxiliary power supply

8.3 ENERGIZATION, START-UP AND SAFE DE-ENERGIZATION

This chapter provides the following information:

- How to check and prepare the inverter before powering-up.
- How to power-up and verify the energization success.
- How to operate the inverter when installed according to the standard project (refer to the [Section 8.2 ELECTRICAL INSTALLATION](#) on page 8-12 and the attached electric project).
- How to de-energize the inverter safely.

8.3.1 Pre-power Checks

The inverter must have already been installed according to the [Chapter 8 INSTALLATION, CONNECTION AND ENERGIZATION](#) on page 8-1. Even when the inverter electric project is different from the suggested one in the attachment, the following recommendations are applicable.



DANGER!

- Always disconnect all the power supplies before making any connections.
- Although the inverter commands the opening of the input circuit breaker, there is no guarantee of its opening and neither that no voltages are present.



DANGER!

- Débranchez toujours toutes les alimentations avant d'effectuer des branchements.
- Bien que l'onduleur commande l'ouverture du coupe-circuit d'ouverture, il n'y a pas de garantie qu'il s'ouvre ni que des tensions sont présentes. Pour ouvrir les armoires moyenne tension, suivez toutes les procédures de mise hors tension de sécurité.

In order to open the medium voltage cabinets, follow all the safe de-energization procedures.

1. Check if all the power, grounding and control connections are correct and tightened.
2. Clean the inverter internally, remove all packing material and installation residues from within the MVW-01 cabinets.
3. Check all motor connections and verify whether its voltage, current and frequency match the inverter specifications.
4. If it is possible, decouple the motor mechanically from the load. If the motor cannot be decoupled, then make sure that rotation in any speed direction (Forward or reverse) is not hazardous to people or to the machine.
5. Close and lock the panel doors.

8.3.2 Initial Power-up (Parameter Settings)

After the pre-power checks the inverter can be powered up:

1. Verify the supply voltages
Verify whether the medium voltage line is available at the input cubicle.
Measure the auxiliary low voltage power supply voltage that feeds the control column and make sure it is within the allowed limits of +10 % / -15 %.
2. Check the control column circuit breakers
Verify if the settings of the control circuit breakers are according to the electric project. Close the control column door.
3. Verify the emergency pushbutton
Make sure the emergency pushbutton is not actuated. In case it is actuated, use the safety key to unlock it.
4. Apply power to the control column
Close the control column auxiliary supply disconnecter switch only after the power-up process be concluded.
5. Verify the first energization success
The first time the panel is energized or when the factory settings are loaded with P204 = 5, the guided start-up routine is initiated. This routine asks the user to program some parameters regarding the inverter and the motor.

8.3.3 Start-up

This section describes the inverter start-up with keypad operation. The considered control mode is V/F 60 Hz.



DANGER!

- High voltages may be present even after the power supply disconnection.
- The following sequence is valid for the standard MVW-01 inverter. The inverter should have already been installed and programmed, according to [Chapter 8 INSTALLATION, CONNECTION AND ENERGIZATION on page 8-1](#).



DANGER!

- Des tensions élevées peuvent être présentes même après déconnexions de l'alimentation.
- La séquence suivante est valable pour l'onduleur du MVW-01 standard. L'onduleur doit déjà avoir été installé et programmé, comme décrit respectivement dans le [Chapter 8 INSTALLATION, CONNECTION AND ENERGIZATION on page 8-1](#).

8.3.3.1 Start-up with HMI Operation and V/F 60 Hz Control Mode

1. Apply power to the panel close the disconnecter switch at the control column power supply input.
2. Once the control column has been energized, the MVC1 or MVC3 control board waits for its initialization, presenting the following message on the HMI:
- After the control has finished its initialization (approximately 10 seconds), the message "Inverter in Undervoltage" is presented on the HMI.



At this moment the inverter is in undervoltage state (DC link is discharged) and the "Ready to Start" pilot light (H1) at the control column door is on, indicating that it is already possible to initiate the inverter pre-charge.

3. Initiate the pre-charge / power section energization.
The MVW-01 inverter pre-charge command must be given manually:
 - With the pilot light "READY TO START" on, press the "POWER-ON" pushbutton (S1).

- Wait until the pre-charge is finished (approximately 10 seconds). During the pre-charge the “PRECHARGE” pilot light (H2) must remain on.
- Once the pre-charge is successfully completed, the “PRE-CHARGE” pilot light goes off and the “INPUT ON” (H3) goes on, indicating that the input transformer circuit breaker was successfully closed.
- The “Inverter Ready” message is displayed on the HMI.

 **NOTE!**
The maximum number of pre-charge procedures that can be performed per hour must be established by the auxiliary transformer supplier.

 **ATTENTION!**
If during the pre-charge any problem occurs, the inverter indicates an error related to it. The possible errors are:
F014 - Fault in the input transformer circuit breaker closure.
F017 - Circuit breaker not ready.
F020 - Pre-charge fault.
Refer to these error (alarm/fault) descriptions in the [Section 14.1 ALARMS/FAULTS AND POSSIBLE CAUSES on page 14-1](#).

 **NOTE!**
The last speed reference value, set via the  and  keys, is saved in the memory. If you want to change this value before enabling the inverter, change it through the parameter P121 (Keypad Speed Reference), which stores the keypad speed reference.

NOTES:

1. If the motor speed direction is inverted, switch off the inverter following the safe de-energization instructions and swap two of the motor cables.
The HMI must indicate the same direction seen looking against the motor shaft end.
2. If the current is too high during the acceleration, especially at low speeds, it is necessary to reduce the acceleration ramp time (P100 or P102) or change P136 - Torque boost setting.
Gradually increase and decrease the P136 content until reaching an operation with approximately constant current throughout the entire speed range. Refer to the parameter description in [Chapter 11 DETAILED PARAMETER DESCRIPTION on page 11-1](#).
3. If F022 occurs during the deceleration, then increase its time via P101 or P103 and check P151.

 **ATTENTION!**
If the inverter receives a general enabling or a start command before the pre-charge has been finished (inverter still in undervoltage state), the command will be ignored and a warning message “Inverter Undervoltage” will be displayed on the HMI.

8.3.4 Safe De-energization Instructions

 **DANGER!**

- Although the inverter commands the opening of the input circuit breaker, there is no guarantee of its opening and neither that no voltages are present, because the capacitors remain charged for a long time and they can also be charged through the auxiliary supply (pre-charge).
- In order to open the medium voltage cabinets, follow all the safe de-energization procedures described next.



DANGER!

- Bien que l'onduleur commande l'ouverture du coupe-circuit d'entrée, il n'y a aucune garantie qu'il s'ouvrira ni qu'aucune tension n'est présente, car les condensateurs restent chargés pendant longtemps et ils peuvent également être chargés par l'alimentation auxiliaire (précharge).
- Pour ouvrir les armoires moyenne tension moyenne, suivez toutes les procédures de mise hors tension de sécurité décrites ci-dessous.

1. Decelerate the motor to a complete stop.
2. Check the DC link voltage at the parameter P004 on the HMI. Open the control panel door and locate the neon lamps of the HVM (High Voltage Monitoring board), mounted on the cabinet left side. The four lamps must be on if the voltage showed via P004 is above 200 V.
3. Press the "POWER OFF" pushbutton. The input transformer circuit breaker is switched off at this moment, and the "INPUT ON" pilot light going off indicates it.



ATTENTION!

If the input transformer circuit breaker does not open with the "POWER OFF" command, then open it manually.

4. Follow the DC link voltage decrease through P004 on the HMI and the HVM neon lamps. When the DC link voltage crosses below 200 V the neon lamps start flashing with progressively lower frequency until going off completely.
Wait until the DC link voltage displayed at P004 on the HMI gets below 25 V.
5. At the input transformer circuit breaker cubicle, extract the circuit breaker from its operation position and close the transformer primary winding grounding switch. Lock the cubicle with the key and/or put a warning sign "System in maintenance".
6. Press the emergency pushbutton located on the control column door and remove its key.
7. Switch off the Q2 circuit breaker in the control column and lock it in the open position with a padlock and/or put a warning sign "System in maintenance".
8. Switch off the Q1 circuit breaker in the control column. Remove the auxiliary power supply.

It is only after the sequence of procedures described here that medium voltage compartment doors can be opened.



DANGER!

If it were not possible to follow the discharge of the DC link capacitors through the parameter P004, as well as through the HVM board neon lamps, due to a malfunction or a previous de energization, follow the instructions 5) through 8) and wait 10 minutes more.



DANGER!

S'il n'était pas possible de suivre la décharge des condensateurs de liaison CC avec le paramètre P004 et les lampes à néon de la carte HVM en raison d'un dysfonctionnement ou une mise hors tension préalable, suivez les instructions 5) jusqu'à 8) et attendez 10 minutes supplémentaires.

9 KEYPAD (HMI) OPERATION

The Graphic HMI Interface (HMI - Human Machine Interface) provides a series of new resources to the medium voltage frequency inverter MVW-01. They are:

- Visualization: text and graphic visualization modes.
- Monitoring: up to 6 parameters can be monitored simultaneously on the screen.
- Navigation: navigation system via menus, with the addition of scroll bars and new keys.
- On-line help function: help in the own HMI (in 3.0x and latest versions, help for parameters an errors).
- Editing: new keys to speed up the parameter edition.

The graphic HMI design, improvements and new functions present an operation, navigation and programming similar to the HMI used with the CFW-11 line, making its use even easier to those familiar with that WEG product line (refer to the [Figure 9.1 on page 9-1](#)).

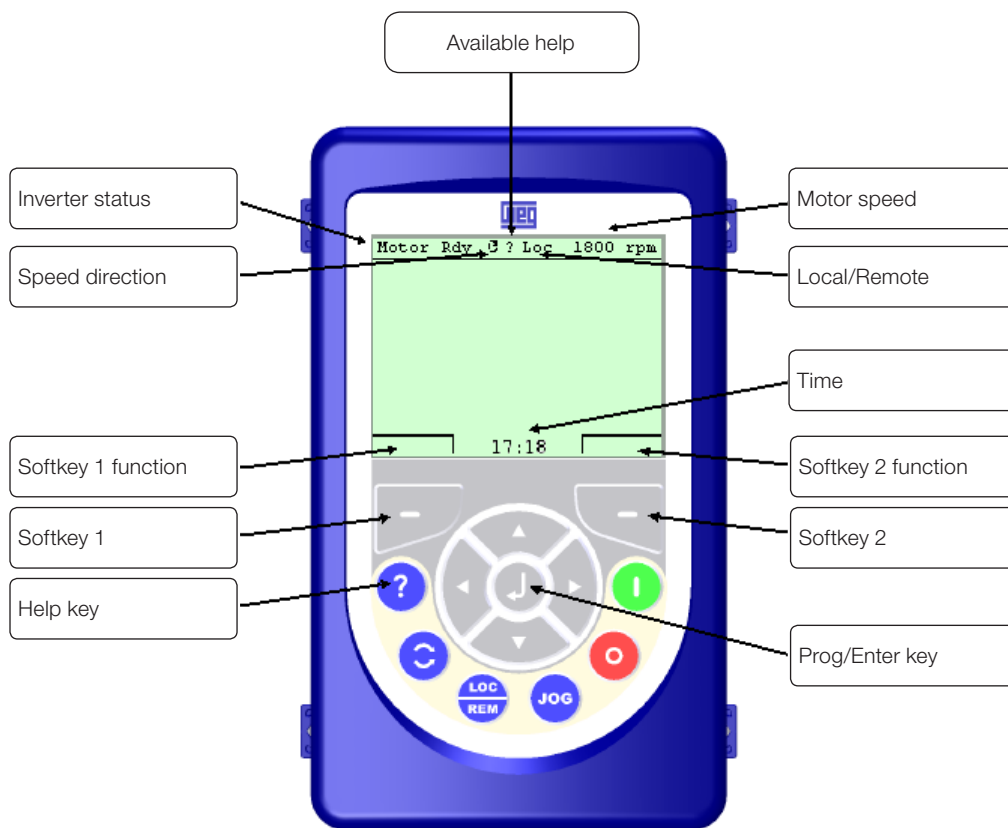

Figure 9.1: MVW-01 inverter Graphic HMI



NOTE!

The MVW-01 3.xx version requires the use of an updated version of the Graphic HMI called Graphic HMI 2 or HMIG2. Therefore, it is not possible to use the conventional Graphic HMI with a 3.xx firmware set.



NOTE!

The HMIG2 upgrades are summarized in the increase of the RAM and ROM memory capacities, so that the operation is identical for both cases and, therefore, no distinctions will be made between the HMIG2 and the former Graphic HMI in the descriptions of this manual.

9.1 INSTALLATION OF THE GRAPHIC HMI IN THE CABINET

The installation of the HMI in the cabinet is done without the need of using the frame, and the fastening is done directly through the screws placed on the movable fins positioned at the HMI back cover, according to the [Figure 9.2 on page 9-2](#).

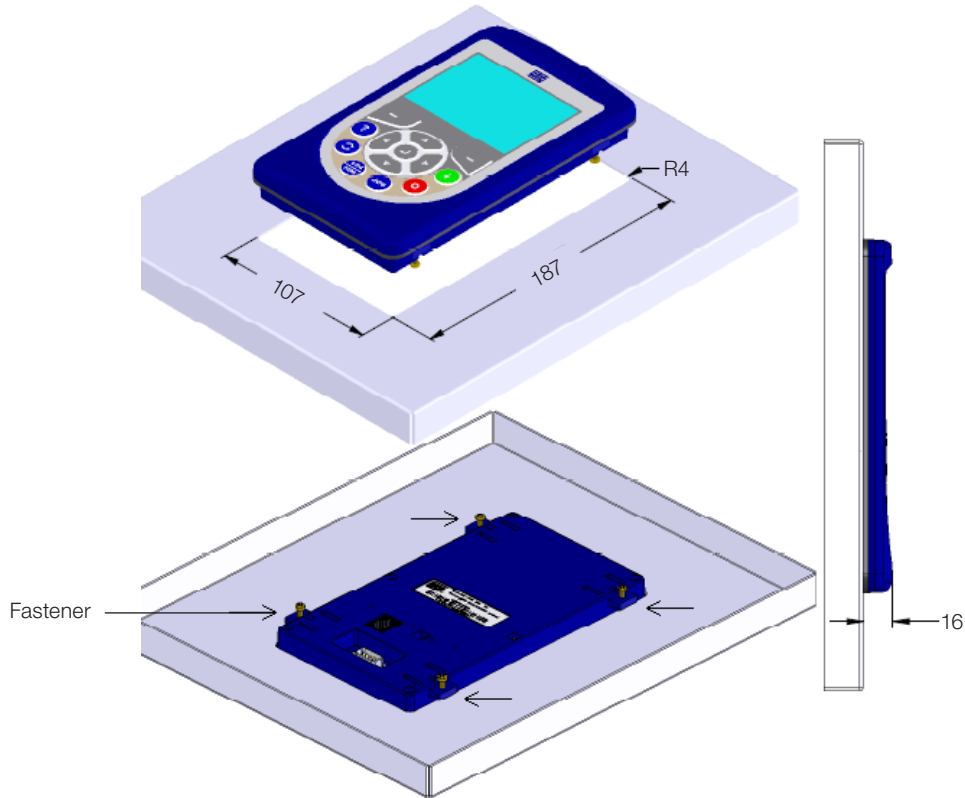

Figure 9.2: Size of the panel cut-out for fixing the Graphic HMI

The connection of the Graphic HMI to the MVC4 board is done with the same cable used for the conventional HMI, and the connection point on the MVC4 board is also the XC8 connector.



NOTE!

- No additional hardware configuration has to be done on the MVC4 board, because it recognizes the type of connected HMI automatically.
- The MVC4 board and the Graphic HMI software versions must be compatible. For instance, if the Graphic HMI software is 3.0X and the MVC4 board version is 3.1X or newer, the HMI will not work properly and a warning of incompatible software version will occur.



ATTENTION!

It is not recommended to connect the Graphic HMI to the MVC4 board with power applied to the control rack.

9.2 STARTING THE USE OF THE GRAPHIC HMI

The communication between the Graphic HMI and the inverter is established with the Modbus RTU protocol (38400 bps, no parity, with 2 stop bits), using as the physical layer the channel. The Graphic HMI works as the communication master.

When the panel is energized the Graphic HMI performs a parameter initialization with the MVC4 board. During this process the firmware versions of the Graphic HMI and of the MVW-01 control boards are exhibited.

The information of the parameters being transferred and a progress bar are also exhibited during the initialization process (refer to the [Figure 9.3 on page 9-3](#)).

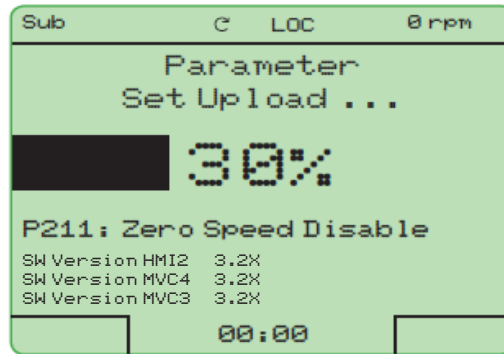

Figure 9.3: Graphic HMI initialization



NOTE!

- In order to be able to start using the Graphic HMI (navigation and parameter edition) it is only necessary that the initialization be successfully concluded and no additional programming is necessary.
- The values of the parameters remain stored in the MVC4 board. If a communication problem occurs and the initialization is not successfully concluded, the Graphic HMI notifies an initialization failure and releases the keypad use, however, any modification in the parameter programming becomes useless because data will not be sent to the MVC4 board.
- If the Graphic HMI is disconnected while the panel is with power, when reconnecting it a new initialization procedure occurs.

9.2.1 Graphic HMI Basic Visualization Modes

In any HMI use situation (visualization mode or active screen) there are standard indications that always will be presented (refer to the [Figure 9.1 on page 9-1](#)):

Header:

- Inverter Status.
- Speed Direction.
- Help Availability.
- Local or Remote Mode.
- Motor Speed (rpm).

Footer:

- Time.
- Function of the 2 Softkeys.

The various modules or visualization screens of the Graphic HMI can be classified into 6 distinct basic types:
Read-only parameters:

- 1 parameter.
- 2 to 4 parameters.
- 5 or 6 parameters.

Navigation:

- Parameter Groups.
- Parameters.
- Error Log.

Parameter edition:

- Numerical Parameters.
- Alphanumerical Parameters.
- Indication of occurred fault, alarm or notification.

Help Function (only for parameters in this software version).

Graphic functions:

- Watch Function.

When the initialization is finished the display enters the parameter monitoring mode. The number of presented parameters can be programmed through the read-only parameter selection parameters (P500 to P505, refer to the [Section 11.6 PARAMETER OF THE GRAPHIC HMI - P490 TO P519 on page 11-90](#) for more details), and the font size varies according to the number of parameters programmed for monitoring, according to the [Figure 9.4 on page 9-4](#).

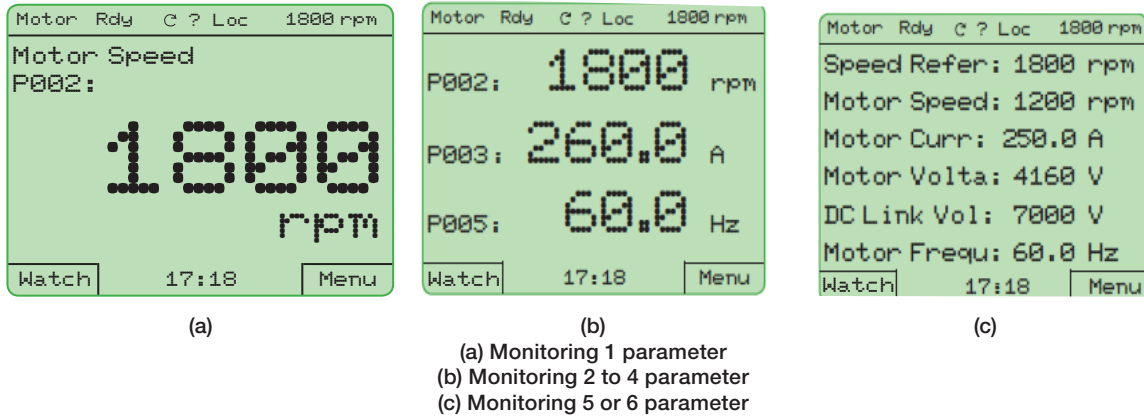

Figure 9.4: (a) to (c) Parameter monitoring modes

In the read-only parameter monitoring mode the main HMI navigation menu can be accessed through the quick access Softkey [Menu] (SK2) or through the [ENTER] key.

9.2.2 Structure of the Parameter Groups

When in the monitoring mode the [Menu] option is selected, the parameter group navigation menu appears ([Table 9.1 on page 9-5](#)).

The Menu is composed by several access levels (refer to the [Table 9.2 on page 9-6](#)). The navigation through these levels is done by means of the softkeys SK1 [return] and SK2 [Select]. In order to select one group the Prog/Enter key or the softkey SK2 [Selec.] can be used.

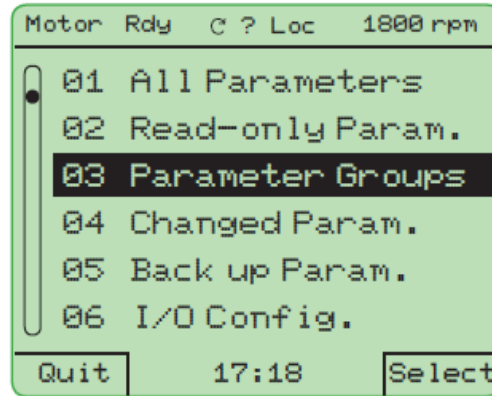

Figure 9.5: Main menu (level 1 group)

Table 9.1: Groups accessed through the main menu

Status	Group	Parameters or Groups to which Access is given
01	All the Parameters	All the parameters with access in a sequential mode.
02	Read-only Parameters	Access just to the read-only parameters.
03	Parameter Groups	Parameters accessed by menus according to their functions.
04	Changed Parameters	Parameters whose contents are different from the factory settings.
05	Backup Parameters	Parameters related to parameter copy functions.
06	I/O Configuration	Parameters for the configuration of digital and analog inputs and outputs.
07	Fault History	Access to the error log (P067).
08	Basic Application	Access to basic parameters.
09	Oriented Start-up	Easy access to configuration parameters.
10	Auto-Setup	Access to automatic configurations.

The selection of the parameters works with the cursor navigating through the sub-groups or through the parameters of the group to which they are associated.

In the navigation modes a scrollbar appears at the HMI left side, with the purpose of helping the navigation by signaling the relative position of the cursor regarding the total of possible groups/parameters.

The inverter parameters can be accessed through the classic sequential structure, or disposed in menu groups according to their functions.

9.2.3 Sequential Access Mode

In order to enter this parameter access mode it is just necessary to press the [Menu] softkey (available in the monitoring mode) and select <01 All the Parameters>.

In this mode all the active parameters are presented in an uninterrupted sequence from the first up to the last parameter (provided that the respective parameter is active).

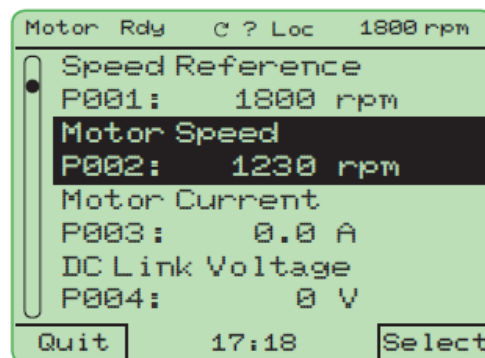

Figure 9.6: Sequential parameter list

9.2.4 Parameter Groups Access Mode

In order to enter this parameter access mode it is necessary to press the [Menu] softkey (available in the monitoring mode) and select <03 Parameter Groups>.

In this mode the parameters are accessed according to their group or to the function to which they belong. Refer to the group structure in [Table 9.2 on page 9-6](#).

Table 9.2: Group, subgroup and parameter structures according to the various navigation levels

Level 1		Level 2		Level 3			
01	All the Parameters						
02	Read-only Parameters						
03	Parameter Groups	20	Ramps				
		21	Speed References				
		22	Speed Limits				
		23	V/F Control				
		24	Adjustable V/F Curve				
		25	V/F Current Limitation				
		26	DC Voltage Limitation				
		27	Dynamic Braking				
		28	Vector Control			90	Speed Regulator
						91	Current Regulator
						92	Flux Regulator
						93	Flying Start
						94	Self-Tuning
						95	Torque Current Limitation
						96	DC Link Regulator
				97	MVW Parameters		
				98	Synchronous Parameters		
		29	HMI				
		30	Local Command				
		31	Remote Command				
		32	3-Wire Command				
		33	FWD/REV Run Command				
		34	Zero Speed Logic				
		35	Multispeed				
		36	Electronic Potentiometer				
		37	Analog Inputs				
		38	Analog Inputs				
		39	Digital Inputs				
		40	Digital/Relay Outputs				
		41	Inverter Data				
		42	Motor Data				
43	Flying Start/Ride-Through						
44	Protections						
45	PID Regulator						
46	DC Braking						
47	Skip Speed						
48	Communication			110	Local/Remote Configuration		
				111	Status/Commands		
				112	DeviceNet		
				113	Serial RS232/485		
				114	Anybus		
		115	Profibus DP				
49	PLC						
50	Trace Function						
51	Special Functions						
04	Changed Parameters						
05	Backup Parameters						
06	I/O Configuration	37	Analog Inputs				
		38	Analog Inputs				
		39	Digital Inputs				
		40	Digital/Relay Outputs				
07	Fault History						
08	Basic Application						
09	Oriented Start-up						
10	Auto-Setup						

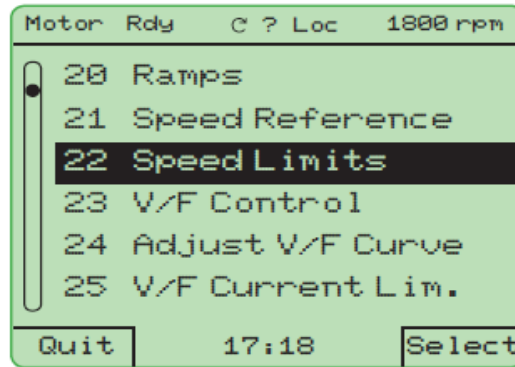

Figure 9.7: Navigation through the group 03 (Parameter Groups)

9.3 PARAMETER EDITION

The activation of the edition or parameter changing mode is executed by pressing the Enter/Prog key or the softkey associated to the parameter navigation.

Once in the edition mode, if the softkey programmed to leave [Return] is used, the modifications are not stored in the parameter memory and the value prior to the edition is restored. In a similar way, by using the softkey programmed to confirm [Select], the new parameter content is stored in the inverter parameter memory.

9.3.1 Numerical

The numerical parameters (refer to the [Figure 9.8 on page 9-7](#)) are changed with the ▲ and ▼ keys, in order to increment and decrement their contents. There is the possibility of changing the parameter contents with a ten times faster rate (x 10), therefore, the ◀ and ▶ keys are used in order to increment and decrement the tens.

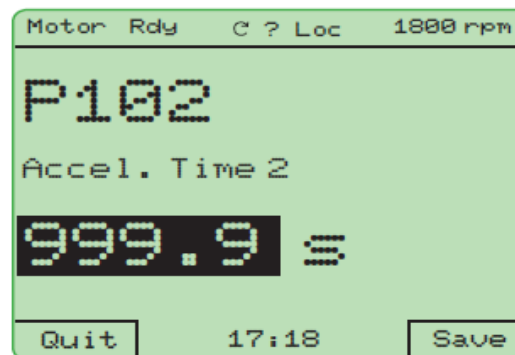

Figure 9.8: Numerical edition

9.3.2 Alphanumerical

In the edition of message type parameters (refer to the [Figure 9.9 on page 9-7](#)) the cursor can be moved with the ▲ and ▼.

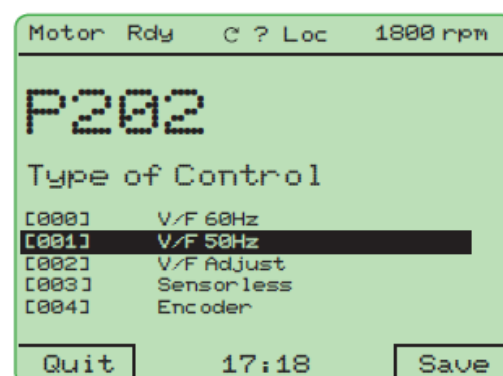

Figure 9.9: Alphanumerical edition

9.4 CONFIGURING THE GRAPHIC HMI

9.4.1 LCD Contrast

The Graphic HMI LCD contrast is adjusted by the parameter P490, which is accessible through the group <29 HMI> or the group <09 Oriented Start-up>. Typical contrast values are between 50 and 75.



NOTE!

After the power on, approximately 60 seconds are necessary for the stabilization of the contrast at the level adjusted in P490. In certain climatic conditions (temperature/humidity) contrast stabilization times longer than 60 may occur.

9.4.2 Configuring the HMI Commands

In order that the Graphic HMI commands work properly, it is necessary to program the local or remote (LOC/REM) inverter commands to be of the 'Serial' type.

Example of LOCAL configuration:

- P220 = 11 (Graphic HMI LOC).
- P221 = 0 (Keypad) or 13 (Graphic HMI).
- P223 = 12 (Graphic HMI FWD).
- P224 = 5 (Graphic HMI).
- P225 = 6 (Graphic HMI).

Example of REMOTE configuration:

- P220 = 12 (Graphic HMI REM).
- P222 = 0 ((Keypad) or 13 (Graphic HMI).
- P226 = 12 (Graphic HMI FDW).
- P227 = 5 (Graphic HMI).
- P228 = 6 (Graphic HMI).

The automatic programming of the parameters described above can be done through the parameter P491 - Graphic HMI Configuration (menu <10 Auto-Setup> or <29 HMI>).

Table 9.3: Graphic HMI commands selection

Option	Description
000	Inactive
001	HMIG Local
002	HMIG Remote

In the [000 Inactive] mode the Graphic HMI is not enabled to send commands to the inverter and the parameters P220 to P228 are programmed with the factory settings.

In the [001 Modbus Local] and [002 Modbus Remote] modes the parameters P220 to P228 are programmed according to the configuration examples described previously.

9.4.3 Configuring the Monitoring Mode Read-Only Parameters

In the monitoring mode the HMI is able to present from 1 to 6 read-only parameters simultaneously. The parameters P500 to P505 select which read-only parameters will be presented (refer to the [Table 9.4 on page 9-9](#) in order to identify the possible programmable parameters).

In order not to present a read-only parameter the parameters P500 to P505 must be programmed with '0 = Inactive'. The number of read-only parameters presented depends on how many parameters from P500 to P505 are programmed different from '0 = Inactive'.

Table 9.4: Possible monitoring mode read-only parameters

Parameter	Description	Full Scale
P001	Speed Reference	P208
P002	Motor Speed	P208
P003	Motor Current	P295
P004	DC Link Voltage	1.35 x P296
P005	Motor Frequency	P403
P007	Motor Voltage	P296
P009	Motor Torque	(P295/P401) x 100 %
P010	Output Power	1.732 x (P295 x P296)
P040	PID	100 %

9.4.4 Configuring the On-Line Graphic (Watch) Function

In the on-line graphic visualization mode (watch function), the user is able to program up to two read-only parameters (refer to the [Table 4.2 on page 4-2](#)) for real time graphic monitoring on the HMI. This programming is done in a similar form to the programming of the monitoring mode (P512 to P519). The variable updating (sampling) is slow, and the objective is of monitoring in real time the inverter situation (refer to the [Figure 9.10 on page 9-9](#)). Data is not saved in any memory device, i.e., it is only for real time monitoring.

The graphic (watch) function is accessed through the [Graphic] softkey, from the parameter monitoring mode.

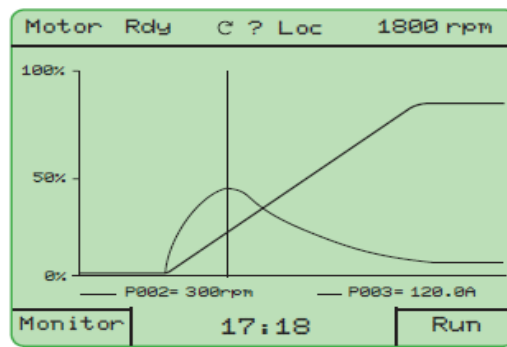
Figure 9.10: Graphic function visualization example

In the graphic mode (watch), it is possible to pause the sampling and navigate through the graphic with the help of a cursor (use the ◀ and ▶ keys). The parameter values corresponding to the cursor location are presented near the parameter numbers below the graphic, according to the [Figure 9.10 on page 9-9](#).

By means of the parameter [P493 Sampling Time] it is also possible to adjust the horizontal graphic scale, by adjusting the sampling time between the points.

The default full scale of the graphic is always 100 % of the programmed parameter full scale. Through the parameters P516 and P517 it is possible to modify the full scale of the parameters programmed for the graphic function.

NOTE!

The [Table 9.4 on page 9-9](#) presents the full scale for the read-only parameters that can be programmed for both, monitoring and graphic function.

9.5 ALARMS AND FAULTS

9.5.1 Alarm/Fault Screen

When fault or alarm occurs in the MVW-01, the Graphic HMI enters the error warning mode (see the [Figure 9.11 on page 9-10](#)). The HMI stays in this error warning mode until the user selects [Quit] or error [Reset], through the correspondent softkeys.

The [Return] option deactivates the notification and allows the user to continue using the HMI, however, the inverter stays in the fault status and it is not possible to enable it.

The [Reset] option causes a general inverter reset and, if the fault persists (the fault cause has not been solved), it is indicated again. If the fault cause has been eliminated, the inverter operates normally again and the fault is stored in the error record.

Alarms are showed in the inverter status field with the Axxx indication. In this case the HMI and the inverter remain operating normally and the alarm is stored in the error record. If one chooses the alarm reset, the procedure is similar to the fault reset (corresponding softkey).

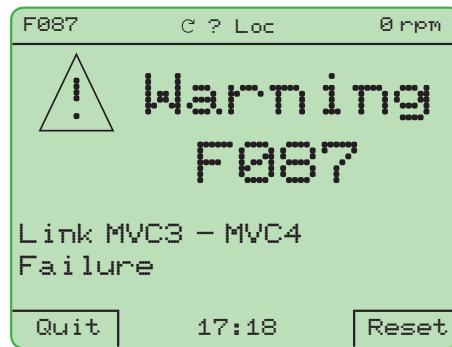

Figure 9.11: Inverter error visualization mode

In case of incorrect inverter programming (see [Table 9.5 on page 9-10](#)) F083 will be displayed.

Table 9.5: Incompatibility between parameters - F083

1	Two or more parameters among P264, P265, P266, P267, P268, P296 and P270 equal to 1 (LOC/REM).
2	Two or more parameters among P265, P266, P267, P268, P269 and P270 equal to 6 (ramp 2).
3	P265 equal to 8 and P266 different from 8 or vice-versa (Forward Run / Reverse Run).
4	P221 or P222 equal to 8 (Multispeed) and P266 ≠ 7 and P267 ≠ 7 and P268 ≠ 7.
5	[P221 = 7 and P222 = 7] and [(P265 ≠ 5 or P267 ≠ 5) or (P266 ≠ 5 or P268 ≠ 5)] (with reference = E.P. and without Dlx = Accelerate E.P. or without Dlx = Decelerate E.P.).
6	[P221 ≠ 7 or P222 ≠ 7] and [(P265 = 5 and P267 = 5 or P266 = 5 and P268 = 5)] (without reference = E.P. and with Dlx = Accelerate E.P. or with Dlx = Decelerate E.P.).
7	P265 or P267 or P269 equal to 14 and P266 and P268 and P270 different from 14 (with Dlx = Start, without Dlx = Stop).
8	P266 or P268 or P270 equal to 14 and P265 and P267 and P269 different from 14 (without Start, with Stop).
9	P220 > 1 and P224 = P227 = 1 and without Dlx = Start/Stop or Dlx = Fast Stop and without Dlx = General Enable.
10	P220 = 0 and P224 = 1 and without Dlx = Start/Stop or Fast Stop and without Dlx = General Enable.
11	P220 = 1 and P227 = 1 and without Dlx = Start/Stop or Fast Stop and without Dlx = General Enable.
12	Dlx = Start and Dlx = Stop, however P224 ≠ 1 and P227 ≠ 1.
13	Two or more parameters among P265, P266, P267, P268, P269 and P270 equal to 15 (Man/Aut).
14	Two or more parameters among P265, P266, P267, P268, P269 and P270 equal to 17 (Disables Flying Start).
15	Two or more parameters among P265, P266, P267, P268, P269 and P270 equal to 18 (DC Link Regulator).
16	P264 = 1 (DI2 = LOC/REM) and P226 = 4 (Selection of Fwd / Rev, Remote Situation by DI2).

9.5.2 Note Screen

Notes are warnings that only notify the user that any situation did not occur in the expected form, and therefore, are not considered errors neither stored in the error log.

Notes usually occur because of configuration errors of the Graphic HMI commands (generating Modbus errors) or because of attempts to command the inverter in not allowed situations (general enabling with the inverter in undervoltage or error).



NOTE!

Notes do not generate events as inverter stopping.

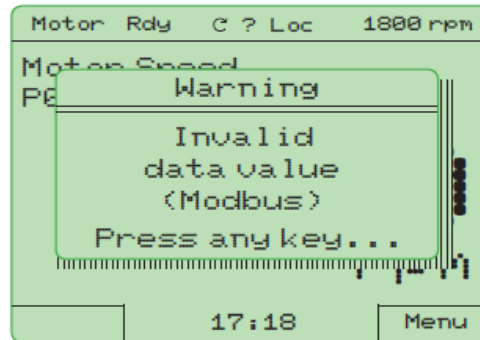
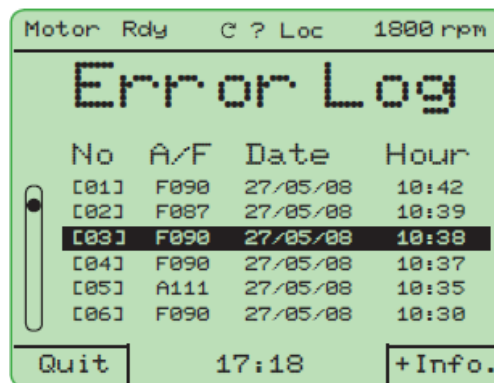

Figure 9.12: Inverter note screen

9.5.3 Error Log

The parameter P067 keeps the information on the inverter last 100 occurred errors (in a similar manner to the conventional HMI), according to the Figure 9.13 on page 9-11.

In order to visualize more information regarding the error, as its description and the status of the inverter at the moment it occurred, it is necessary to select the [+Info] option through the corresponding softkey (refer to the Figure 9.13 on page 9-11).



(a) Error Log P067

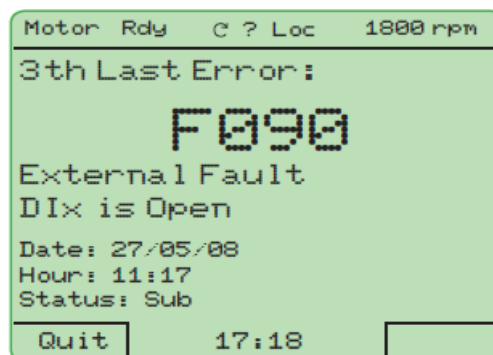

(b) More information on the error

Figure 9.13: (a) and (b) - More information on the error

9.6 HELP FUNCTION

The Graphic HMI has an on-line help function. For the parameters and situations where the help is available, an indication in form of a question mark is presented at the top strip of the HMI display (refer to the [Figure 9.1 on page 9-1](#)). By means of the help key [?] the user gets access to the explanatory text of the corresponding parameter or function.

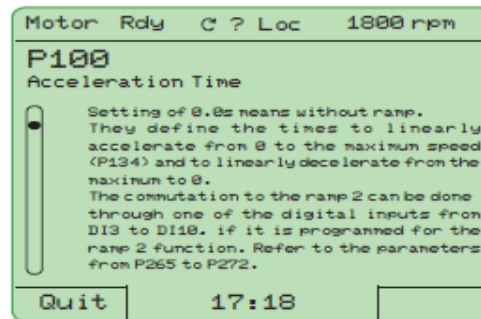

Figure 9.14: Help function visualization mode

10 OPTIONAL ACCESSORIES AND BOARDS

10.1 MVC4 SIGNAL AND CONTROL CONNECTIONS

The signal (analog inputs/outputs) and control (digital inputs/outputs and relay outputs) connections are made at the following terminal strips on the MVC4 control board (refer to the [Figure 10.1 on page 10-1](#)).

XC1A : digital signals.

XC1B : analog signals.

XC1C : relay outputs.

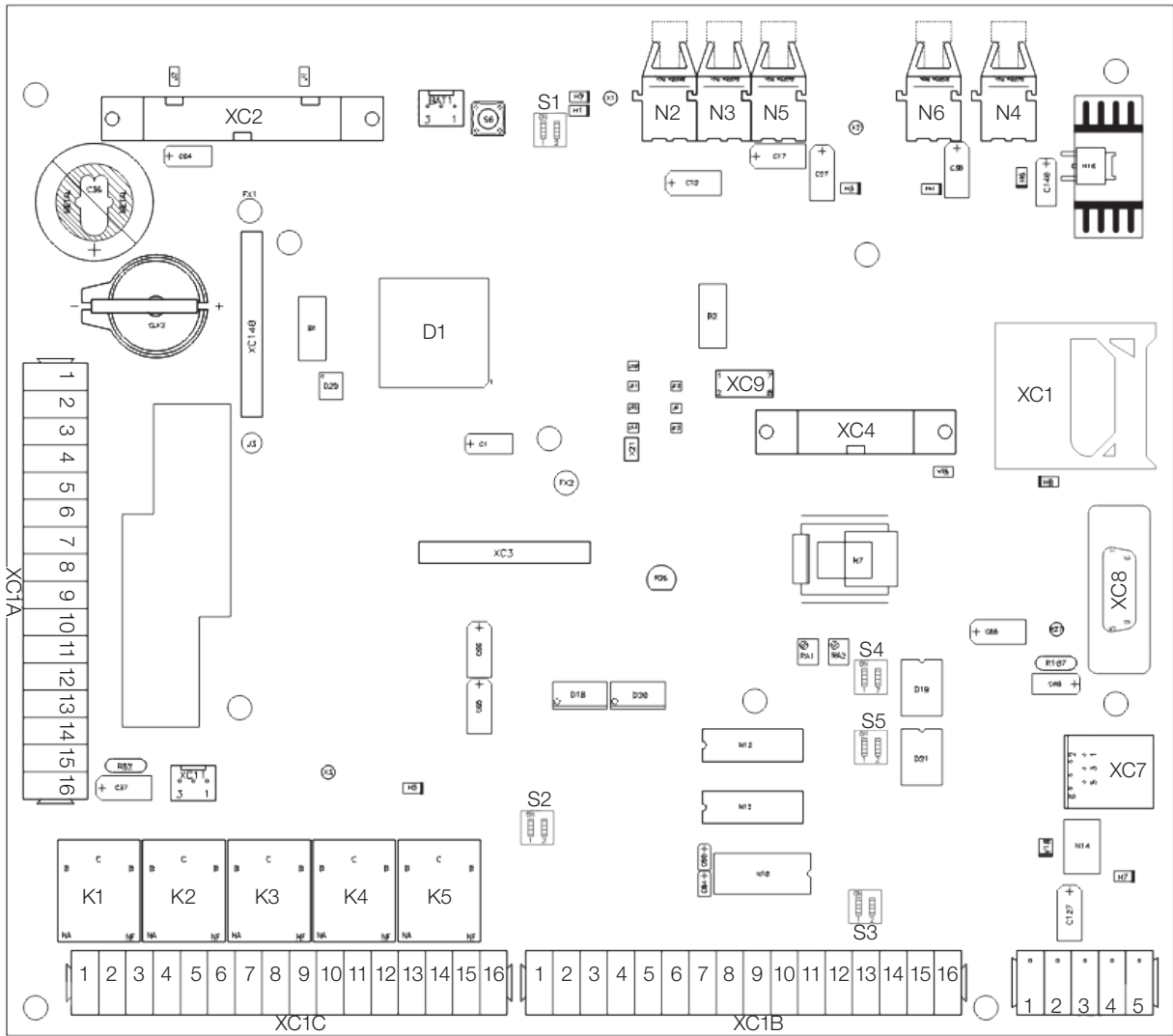
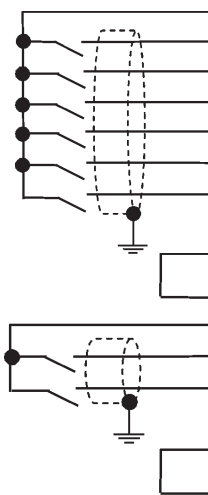
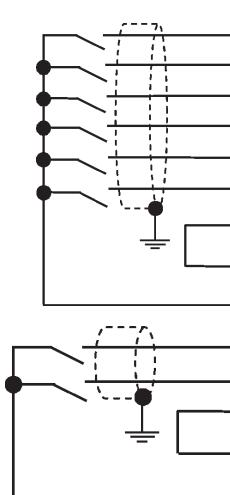

Figure 10.1: MVC4 - Customer connectors



Terminal Strip XC1A		Factory Standard Function	Specifications	
1	24 Vdc	Supply for the digital inputs	6 isolated digital inputs Minimum high level: 18 Vdc Maximum low level: 3 Vdc Maximum voltage: 30 Vdc Input current: 11 mA @ 24 Vdc	
2	DI1	Start / Stop		
3	DI2	FWD / REV Section (Remote mode)		
4	DI3	No function		
5	DI4			
6	DI5	JOG (Remote mode)		
7	DI6	Ramp 2 Selection	Isolated 24 Vdc ± 8 %, capacity: 90 mA	
8	24 Vdc	Supply for the digital inputs		
9	COM	Digital inputs DI1 to DI6 common point		-
10	DGND*	0 V reference of the 24 Vdc supply	Grounded	
11	24 Vdc	Supply for the digital inputs	Identical to the DI1 to DI6 specification	
12	DI9	No function		
13	DI10			
14	24 Vdc	Supply for the digital inputs	Isolated 24 Vdc ± 8 %, capacity: 90 mA	
15	COM	Digital inputs DI9 and DI10 common point		-
16	DGND*	0 V reference of the 24 Vdc supply		Grounded

Figure 10.2: XC1A terminal strip description: active high digital inputs



Terminal Strip XC1A		Factory Standard Function	Specifications	
1	24 Vdc	Supply for the digital inputs	6 isolated digital inputs Minimum high level: 18 Vdc Maximum low level: 3 Vdc Maximum voltage: 30 Vdc Input current: 11 mA @ 24 Vdc	
2	DI1	Start / Stop		
3	DI2	FWD / REV Section (Remote mode)		
4	DI3	No function		
5	DI4			
6	DI5	JOG (Remote mode)		
7	DI6	Ramp 2 Selection	Isolated 24 Vdc ± 8 %, capacity: 90 mA	
8	24 Vdc	Supply for the digital inputs		
9	COM	Digital inputs DI1 to DI6 common point		-
10	DGND*	0 V reference of the 24 Vdc supply	Grounded	
11	24 Vdc	Supply for the digital inputs	Identical to the DI1 to DI6 specification	
12	DI9	No function		
13	DI10			
14	24 Vdc	Supply for the digital inputs	Isolated 24 Vdc ± 8 %, capacity: 90 mA	
15	COM	Digital inputs DI9 and DI10 common point		-
16	DGND*	0 V reference of the 24 Vdc supply		Grounded

Figure 10.3: XC1A terminal strip description: active low digital inputs

Terminal Strip XC1B		Factory Default Function	Specifications
1	+ REF	Positive reference for potentiometer	+5.4 V ± 5 %, capacity: 2 mA
2	AI1+	Analog input 1: speed reference (remote mode)	Differential, resolution: 10 bits, Impedance: 400 kΩ [0 to 10 V] 500 Ω (0 to 20) mA/(4 to 20) mA]
3	AI1-		
4	- REF	Negative reference for potentiometer	- 4.7 V ± 5 %, capacity: 2 mA
5	AI2+	Analog input 2: No function	Differential, resolution: 9 bits, Impedance: 400 kΩ [-10 V to +10 V] 500 Ω [0 to 20) mA/(4 to 20) mA]
6	AI2-		
7	AO1	Analog output 1: Speed	(0 to 10) V, R _L ≥ 10 kΩ (Maximum load) Resolution: 11 bits
8	DGND	0 V Reference for analog outputs	Grounded through a 5.1 Ω resistor
9	AO2	Analog output 2: motor current	0 to +10 V, R _L ≥ 10 kΩ (Maximum load) Resolution: 11 bits
10	DGND	0 V Reference for analog outputs	Grounded through a 5.1 Ω resistor
11	AI5+	Analog input 5: No function	Isolated analog input signal: (0 to 10) V or (0 to 20) mA / (4 to 20) mA Resolution: 10 bits Impedance: 400 kΩ [0 V to 10 V] 500 Ω [(0 to 20) mA/(4 to 20) mA]
12	AI5-		
13	AO5	Analog output 5: Speed	Isolated analog output signals: (0 to 20) mA / (4 to 20) mA Scales: Refer to parameter descriptions Resolution: 11 bits (0.05 % of the full scale) R _L ≤ 600 Ω
14	GND A05	0 V Reference for analog output 5	
15	AO6	Analog output 6: Motor current	
16	GND A06	0 V Reference for analog output 6	

Figure 10.4: XC1B terminal strip description: analog inputs and outputs

Table 10.1: XC1C terminal strip description: relay outputs

Terminal Strip XC1C		Factory Default Function	Specifications
1	RL1 NA	Relay output 1- Without error	Contact capacity: 1 A 240 Vac
2	RL1 C		
3	RL1 NF		
4	RL2 NA	Relay output 2 - N > Nx	
5	RL2 C		
6	RL2 NF		
7	RL3 NA	Relay output 3 - N* > Nx	
8	RL3 C		
9	RL3 NF		
10	RL4 NA	Relay output 4 - No function	
11	RL4 C		
12	RL4 NF		
13	RL5 NA	Relay output 5 - No function	
14	RL5 C		
15	RL5 NF		
16	-	-	

Note:
 NF = normally closed contact,
 NA = normally open contact,
 C = common.

Table 10.2: Configuration of the switches

Signal	Factory Default Function	Setting Element	Selection
AI1	Speed reference	S2.A	OFF - (0 to 10) V ⁽¹⁾ ON - (0 to 20) mA / (4 to 20) mA
AI2	No function	S2.B	OFF - (0 to 10) V ⁽¹⁾ ON - (0 to 20) mA / (4 to 20) mA
AI5	No function	S3.A	OFF - (0 to 10) V ⁽¹⁾ ON - (0 to 20) mA / (4 to 20) mA
AO5	Speed	S4.A	OFF - (0 to 20) mA ⁽¹⁾ ON - (4 to 20) mA
AO6	Motor current	S5.A	OFF - (0 to 20) mA ⁽¹⁾ ON - (4 to 20) mA

(1) Factory default.

Related parameters: P221, P222, P234 to P240.

During the signal and control wiring installation, pay attention to:

1. Cable gauge 0.5 mm² to 1.5 mm².
2. Maximum torque: 0.50 N.m (4.50 lbf.in).
3. XC1A, XC1B and XC1C wiring must be made with shielded cables and be separated from other cables (power, 110/220 V command, etc.). If crossing of these cables is unavoidable, install them perpendicularly, keeping a minimum separation distance of 5 cm (2 in) at the crossing point.

Connect the shield as shown below:

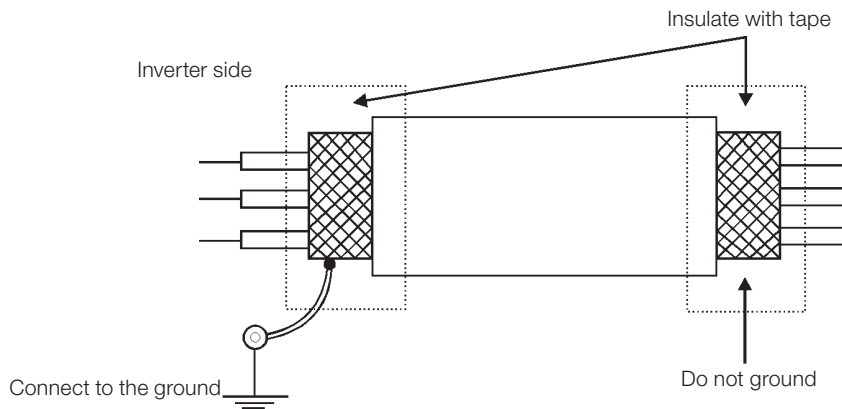

The shield connection screws are located on the MVC4 board and on its mounting plate

Figure 10.5: Shield connection

4. It is necessary to use galvanic isolators at the XC1B terminal strip signals for wiring distances longer than 50 m (150 ft).
5. Relays, contactors, solenoids or electromagnetic braking coils installed near inverters can generate interference in the control circuit. In order to eliminate this interference, connect RC suppressors in parallel with the coils of AC relays. Connect a free-wheeling diode in case of DC relays/coils.
6. When an external keypad (HMI) is used (Refer to [Chapter 9 KEYPAD \(HMI\) OPERATION on page 9-1](#)), separate the cable that connects the keypad to the inverter from other cables of the installation, keeping a minimum distance of 10 cm (4 in) between them.

10.2 FUNCTION EXPANSION BOARDS

The function expansion boards increase the MVC4 control board functions. There are 3 expansion boards available and their selection depends on the application and the desired functions. The three boards cannot be used simultaneously. The difference between the EBA and EBB boards is in the analog inputs/outputs. The EBC1 board serves for the encoder connection; however, it does not have its own power supply as do the EBA/EBB boards. Next, the detailed description of those boards is presented.

10.2.1 EBA (I/O Expansion Board A)

The EBA board can be supplied in different configurations, created from the combination of specific functions.

The available configurations are shown in the next table.

Table 10.3: EBA board versions and available features

Available Features	EBA Board models - Code		
	EBA.01- A1	EBA.02-A2	EBA.03-A3
Differential input for incremental encoder with 12 V / 200 mA isolated internal power supply, feedback for speed regulator, digital speed measurement, 14 bit resolution, 100 kHz maximum signal frequency.	Available	Not available	Not available
Buffered encoder output signals: isolated input signal repeater, differential output, available to external 5 V to 15 V power supply.	Available	Not available	Not available
Analog differential input (AI4): 14 bits (0.006 % of the full scale range), bipolar: -10 V to +10 V, (0 to 20) mA / (4 to 20) mA programmable.	Available	Não disponível	Available
2 Analog outputs (AO3/AO4): 14 bits (0.006 % of the range $[\pm 10 \text{ V}]$), bipolar: -10 V to + 10 V, programmable.	Available	Not available	Available
Isolated RS-485 serial port.	Available	Available	Not available
Digital Input (DI7): isolated, programmable, 24 V.	Available	Available	Available
Digital Input (DI8) with special function for motor thermistor (PTC): actuation 3.9 k Ω , release 1.6 k Ω .	Available	Available	Available
2 isolated Open Collector transistor outputs (DO1/DO2): 24 V, 50 mA, programmable.	Available	Available	Available



NOTE!

The use of the RS-485 serial interface does not allow the use of the standard RS-232 input - they cannot be used simultaneously!

Terminal Strip XC4		Factory Default Function	Specifications
1	NC	Not connected.	-
2	DI8	Motor Thermistor Input 1r - PTC 1 (P270 = 16, refer to the Figure 11.34 on page 11-59). For operation as a normal DI, refer to P270 and Figure 11.35 on page 11-60	Actuation 3.9 kΩ, Release:1.6 kΩ Minimum resistance: 100 Ω
3	DGND (DI8)	Motor Thermistor Input 2 - PTC 2 (P270 = 16, refer to the Figure 11.34 on page 11-59). For operation as a normal DI, refer to P270 and Figure 11.35 on page 11-60	Reference to DGND (DI8) through a 249 Ω resistor
4	DGND	0 V reference of the 24 Vdc	Grounded via a 249 Ω resistor
5	DO1	Transistor output 1: Not used	Isolated, open collector, 24 Vdc, 50 mA maximum, Required load (RL) ≥ 500 Ω
6	COMUM	Common point for Digital Input DI7 and Digital Outputs DO1 and DO2	-
7	DO2	Transistor output 2: Not used	Isolated, open collector, 24 Vdc, 50 mA maximum, Required load (Rc) ≥ 500 Ω
8	24 Vdc	Power Supply for the digital inputs/outputs	24 Vdc ±8 %, isolated, Capacity: 90 mA
9	DI7	Isolated Digital Input: Not used	Minimum high level: 18 Vdc Maximum low level: 3 Vdc Maximum voltage: 30 Vdc Input current: 11 mA @ 24 Vdc
10	SREF	Reference for RS-485	Isolated RS-485 serial port
11	A-LINE	RS-485 A-LINE (-)	
12	B-LINE	RS-485 B-LINE (+)	
13	AI4 +	Analog input 4: Speed reference Program P221 = 4 or P222 = 4	Differential analog input programmable at P246: -10 V to +10 V or (0 to 20) mA / (4 to 20) mA Resolution: 14 bits (0.006 % of full scale range) Impedance: 40 kΩ (-10 V to +10 V) 500 Ω [(0 to 20) mA / (4 to 20) mA]
14	AI4 -		
15	AGND	0 V reference for analog output (internally grounded)	Analog outputs signals: -10 V to +10 V. Scales: see P255 and P257 Chapter 11 DETAILED PARAMETER DESCRIPTION on page 11-1 Resolution: 14 bits (0.006 % of ±10 V range). Required load (Rc) ≥ 2 kΩ
16	AO3	Analog output 3: Speed	
17	AGND	0 V reference for analog output (internally grounded)	
18	AO4	Analog output 4: Motor current	External power supply: 5 V to 15 V Consumption: 100 mA @ 5 V not including the outputs
19	+ V	Available to be connected to an external power supply to feed the encoder repeater output (XC8)	
20	COM 1	0 V reference of the external power supply	

Figure 10.6: Terminal Block description (complete EBA board)

10

ENCODER CONNECTION: Refer to [Section 10.3 INCREMENTAL ENCODER on page 10-13](#).

INSTALLATION

The EBA board is installed directly on the MVC4 control board, secured with spacers and connected via terminal blocks XC11 (24 V) and XC3.

Mounting instructions:

1. De-energize the control rack.
2. Configure the board via S2 and S3 DIP switches (refer to the [Table 10.4 on page 10-8](#)).
3. Carefully insert XC3 connector (EBA) into the female connector XC3 on the MVC4 control board. Make sure that all pins fit in the XC3 connector.
4. Press on the EBA board (near to XC3) and on the left top edge until the complete insertion of the connector and the plastic spacer.

5. Secure the board to the 2 metallic spacers with the 2 provided bolts.
6. Plug the XC11 connector of the EBA board to the XC11 connector on the MVC4 control board.

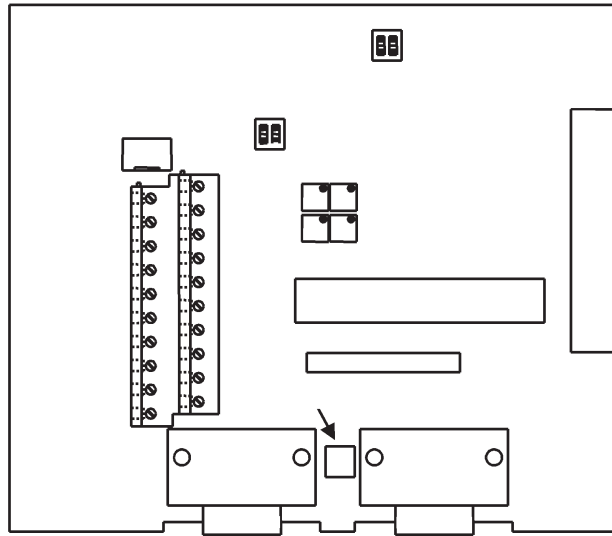

Figure 10.7: EBA board installation procedure

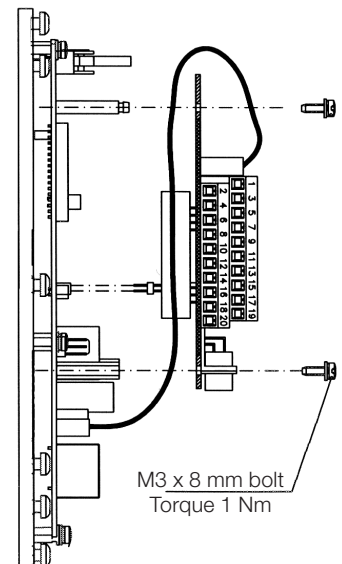
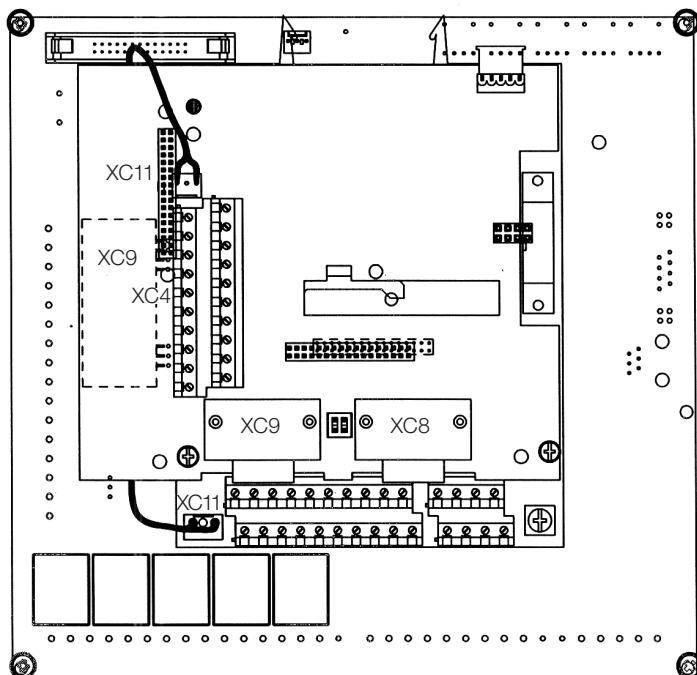
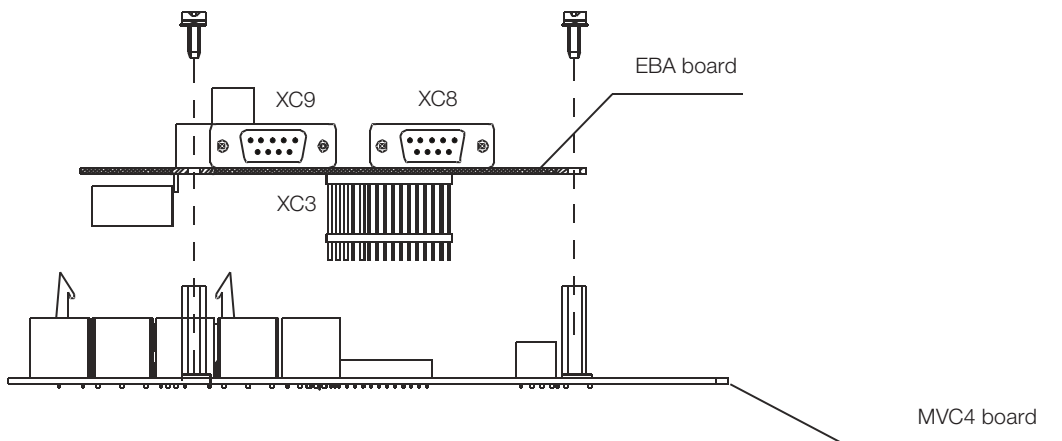

Figure 10.8: EBA board installation procedure

Table 10.4: EBA board configuration of setting elements

Switch	Function - Factory Setting	OFF (Standard)	ON
S2.1	AI4 - Speed Reference	(0 to 10) V	(0 to 20) mA or (4 to 20) mA
S3.1	RS-485 B - LINE (+)	Without termination	With 120 Ω termination
S3.2	RS-485 A - LINE (-)		

Note: Both switches, S3.1 and S3.2, must be adjusted for the same option.

Table 10.5: EBA board trimpot configurations

Trimpot	Function	Factory Default Function
RA1	AO3 - offset	Motor speed
RA2	AO3 - gain	
RA3	AO4 - offset	Motor current
RA4	AO4 - gain	



NOTE!

The external signal and control wiring must be connected to XC4 (EBA), following the same recommendations as for the wiring of the MVC4 control board (refer to the [Section 10.1 MVC4 SIGNAL AND CONTROL CONNECTIONS on page 10-1](#)).

10.2.2 EBB (I/O Expansion Board B)

The EBB board can be supplied in different configurations, created from the combination of specific functions.

The available functions are presented in the [Table 10.6 on page 10-8](#).

Table 10.6: EBB board versions and available features

Available Features	EBB Board Models - Code				
	EBB.01 B1	EBB.02 B2	EBB.03 B3	EBB.04 B4*	EBB.05 B5
Differential input for incremental encoder with 12 V / 200 mA isolated internal power supply, feedback for speed regulator, digital speed measurement, 14 bit resolution, 100 kHz maximum signal frequency.	Available	Available	Not available	Available	Not available
Buffered encoder output signals: isolated input signal repeater, differential output, available to external 5 V to 15 V power supply.	Available	Not available	Not available	Available	Not available
Analog differential input (AI3): 10 bits (0 to 10) V, (0 to 20) mA / (4 to 20) mA, programmable.	Available	Not available	Available	Available	Not available
2 Analog outputs (AO1'/AO2'): 11 bits (0.05 % of the full scale range), (0 to 20) mA / (4 to 20) mA, programmable.	Available	Not available	Available	Available	Available
Isolated RS-485 serial port.	Available	Not available	Not available	Available	Not available
Digital input (DI7): isolated, programmable, 24 V.	Available	Available	Available	Available	Not available
Digital input (DI8) with special function for motor thermistor (PTC): actuation 3.9 kΩ, release 1.6 kΩ.	Available	Available	Available	Available	Not available
2 isolated Open Collector transistor outputs (DO1/DO2): 24 V, 50 mA, programmable.	Available	Available	Available	Available	Not available

* Board with 5 V encoder power supply.



NOTE!

The use of the RS-485 serial interface does not allow the use of the standard RS-232 input - they cannot be used simultaneously.
The analog outputs AO1' and AO2' have the same functions and parameters as AO1 and AO2 on the MVC4 control board.

Terminal Strip XC5		Factory Default Function	Specifications
1	NC	Not connected	-
2	DI8	Motor thermistor input 1 - PTC 1 (P270 = 16, refer to the Figure 11.34 on page 11-59). For operation as a normal DI, refer to P270 Figure 11.35 on page 11-60	Actuation 3.9 kΩ, Release: 1.6 kΩ Minimum resistance: 100 Ω
3	DGND (DI8)	Motor thermistor input 2 - PTC 2 (P270 = 16, refer to the Figure 11.34 on page 11-59). For operation as a normal DI, refer to P270 Figure 11.35 on page 11-60	Reference to DGND (DI8) through a 249 Ω resistor
4	DGND	0 V reference of the 24 Vdc	Grounded via a 249 Ω resistor
5	DO1	Transistor output 1: not used	Isolated, open collector, 24 Vdc, 50 mA maximum, Required load (RL) ≥ 500 Ω
6	COMUM	Common point for Digital Input DI7 and Digital Outputs DO1 and DO2	-
7	DO2	Transistor output 2: Not used	Isolated, open collector, 24 Vdc, 50 mA maximum, Required load (RL) ≥ 500 Ω
8	24 Vdc	Power Supply for the digital inputs/outputs	24 Vdc ±8 %, Isolated, Capacity: 90 mA
9	DI7	Isolated Digital Input: not used	Minimum high level: 18 Vdc Maximum low level: 3 Vdc Maximum voltage: 30 Vdc Input current: 11 mA @ 24 Vdc
10	SREF	Reference for RS-485	Isolated RS-485 serial port
11	A-LINE	RS-485 A-LINE	
12	B-LINE	RS-485 B-LINE	
13	AI3 +	Analog input 3: speed reference Program P221 = 3 or P222 = 3	Isolated analog input programmable at P243: (0 to 10) V or (0 to 20) mA/(4 to 20) mA Resolution: 10 bits (0.1 % of full scale range) Impedance: 400 kΩ (0 to 10) V 500 Ω [(0 to 20) mA/(4 to 20) mA]
14	AI3 -		
15	AGND ¹	0 V reference for analog output (internally grounded)	Isolated analog outputs signals: (0 to 20) mA / (4 to 20) mA Scale: Refer to the description of parameters P251 and P253 in Chapter 11 DETAILED PARAMETER DESCRIPTION on page 11-1 (P251 and P253)
16	AO1 ¹	Analog output 1: speed	
17	AGND ¹	0 V reference for analog output (internally grounded)	Resolution: 11 bits (0.5 % of full scale range) Required load ≥ 600 Ω
18	AO2 ¹	Analog output 2: motor current	
19	+ V	Available to be connected to an external power supply to feed the encoder repeater output (XC8)	External power supply: 5 V to 15 V Consumption: 100 mA @ 5 V, not including the outputs
20	COM 1	0 V reference of the external power supply	

Figure 10.9: XC5 Terminal Block description (complete EBB board)



ATTENTION!

The analog input AI3 and the analog outputs AO1¹ and AO2¹ isolation has the purpose of interrupting ground loops. Do not connect them to high potentials.

ENCODER CONNECTION: refer to [Section 10.3 INCREMENTAL ENCODER on page 10-13](#).

INSTALLATION

The EBB board is installed directly on the MVC4 control board, secured with spacers and connected via terminal blocks XC11 (24 V) and XC3.

Mounting instructions:

1. De-energize the control rack.
2. Configure the board via S4, S5, S6 and S7 DIP switches (refer to the [Table 10.7 on page 10-11](#)).
3. Carefully insert XC3 connector (EBB) into the female connector XC3 on the MVC4 control board. Make sure that all pins fit in the XC3 connector.

4. Press on the EBB board (near to XC3) and on the left top edge until the complete insertion of the connector and the plastic spacer.
5. Secure the board to the 2 metallic spacers with the 2 provided bolts.
6. Plug the XC11 connector of the EBB board to the XC11 connector on the MVC4 control board.

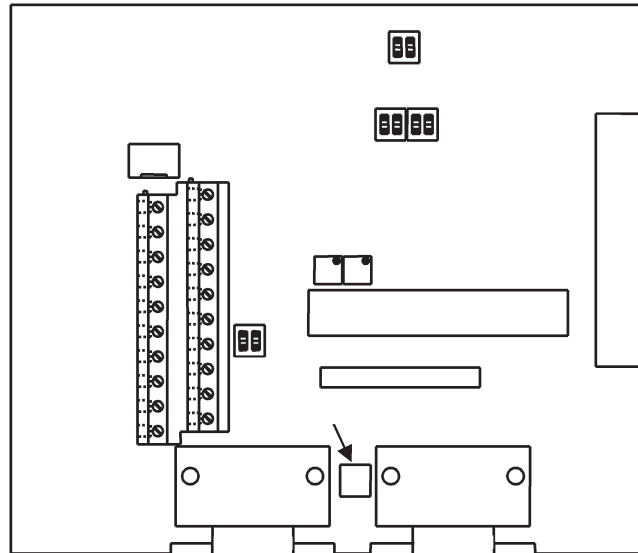

Figure 10.10: EBB board layout

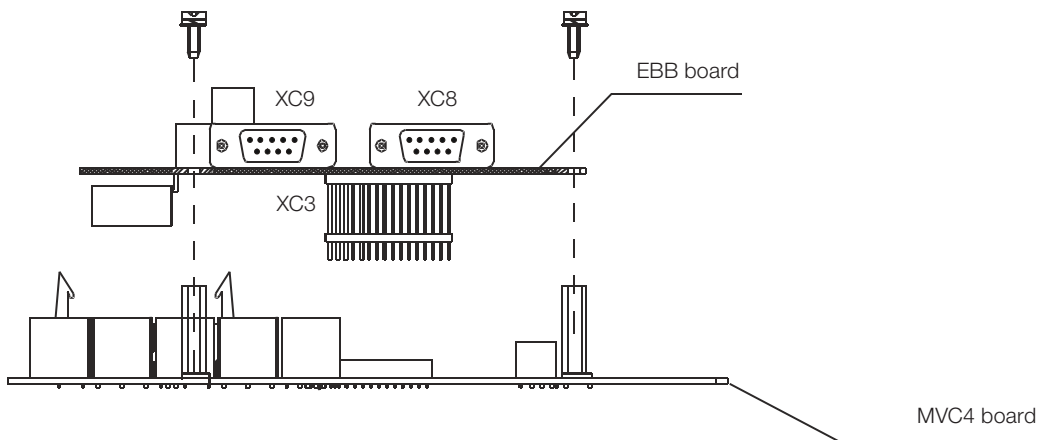

Figure 10.11: EBB board installation procedure

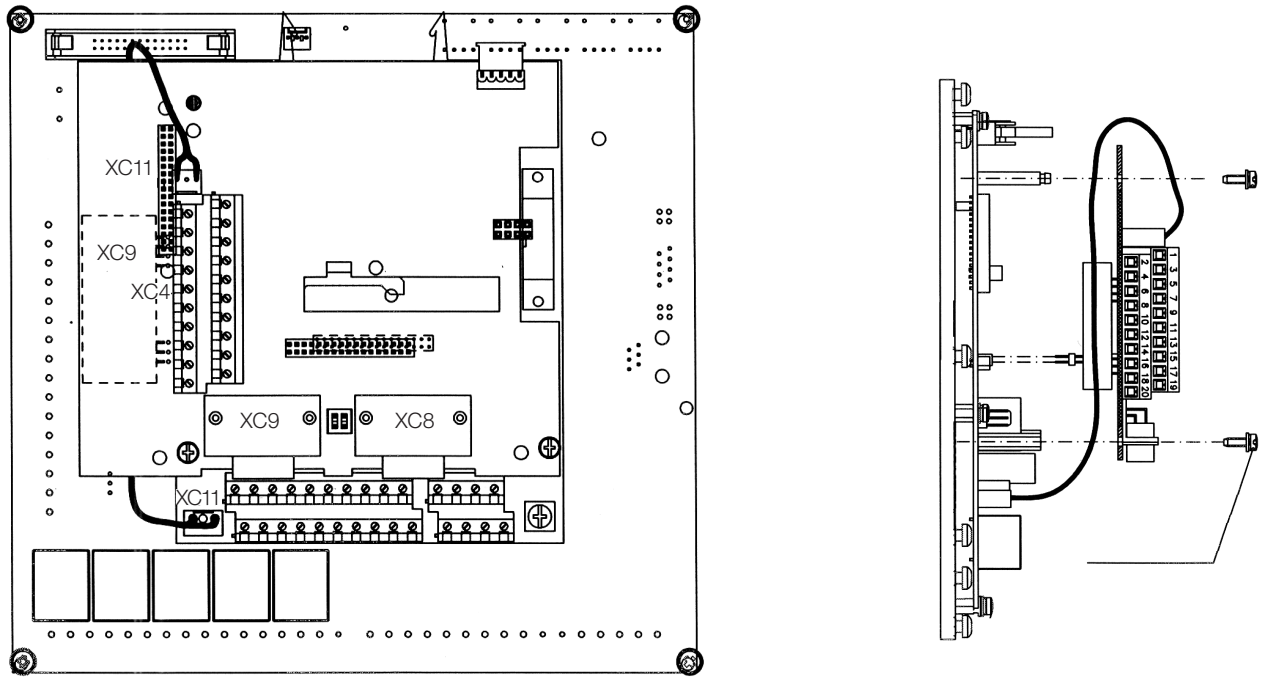

Figure 10.12: EBB board installation procedure

Table 10.7: EBB board DIP switch configurations

Switch	Function - Factory Setting	OFF	ON
S4.1	AI3 - Speed Reference	(0 to 10) V ⁽¹⁾	(0 to 20) mA or (4 to 20) mA
S5.1 and S5.2	AO1 - Speed	(0 to 20) mA ⁽²⁾	(4 to 20) mA ⁽¹⁾
S6.1 and S6.2	AO2 - Motor Current		
S7.1 and S7.2	RS-485 B - LINE (+)	Without termination ⁽¹⁾	With 120 Ω termination
	RS-485 A - LINE (-)		

(1) Factory default setting. Note: Each group of switches must be set for the same option (ON or OFF). E.g., S6.1 and S6.2 = ON.
 (2) When the outputs are set to (0 to 20) mA, it may be necessary to readjust the full scale.

Table 10.8: EBB board trimpot configurations

Trimpot	Function	Factory Default Function
RA5	AO1 Full scale adjustment	Motor speed
RA6	AO2 Full scale adjustment	Motor current



NOTE!

The external signal and control wiring must be connected to XC5 (EBB), following the same recommendations as for the wiring of the MVC4 control board (refer to the [Section 10.1 MVC4 SIGNAL AND CONTROL CONNECTIONS](#) on page 10-1).

10.2.3 PLC2



NOTE!

For more information on the PLC2 board, refer to the PLC2 V1.5x specific manual.

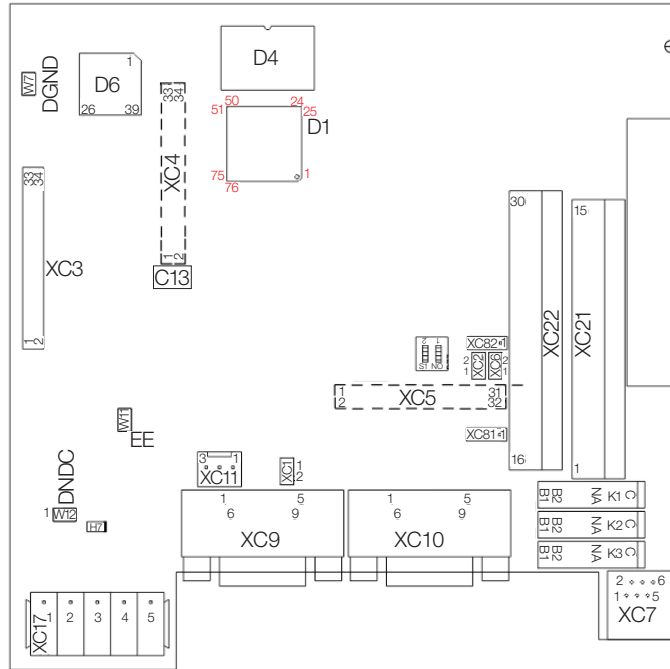

Figure 10.13: PLC2 connectors

The connectors and their terminals function are described below.

XC21 Connector: Relay Outputs and Digital Inputs

XC21 Connector			Function	Specification
1	C	DO1	Digital relay outputs	Contact capacity: 3 A 250 Vac
2	N			
3	C			
4	NA	DO2		
5	C			
6	NA			
7	COM DO	Reference for digital outputs DO4, DO5, DO6	-	
8	DO4	Bidirectional opto-isolated Digital outputs	Maximum voltage: 48 Vdc Current capacity: 500 mA	
9	DO5			
10	DO6			
11	COM DI	Reference for digital inputs DI1 to DI9	-	
12	DI9	Bidirectional Isolated digital Inputs	Input voltage: (15 to 30) Vdc Input current: 11 mA @ 24 Vdc	
13	DI8			
14	DI7			
15	DI6			

Figure 10.14: Description of XC21 connector



ATTENTION!

(*) External power supply.

XC22 Connector: Transistor Outputs and Digital Inputs

XC22 Connector		Function	Specifications
16	PTC1	Motor thermistor input	Actuation: 3.9 k Release: 1.6 k Minimum resistance: 100 Ω
17	PTC2	PTC	
18	GND ENC	Reference for the power supply of the encoder input	-
19	+ ENC	Encoder input power supply	Controlled 5 Vdc or (8 to 24) Vdc Current consumption: 50 mA + Encoders current (**)
20	-	AO2	(-10 to +10) Vdc or (0 to 20) mA 12 Bits
21	+		
22	-	AO1	(-10 to +10) Vdc or (0 to 20) mA 12 Bits
23	+		
24	-	AI1	(-10 to +10) Vdc or (-20 to +20) mA 14 Bits
25	+		
26	DI1	Bidirectional, Isolated Digital Inputs	Input voltage: (15 to 30) Vdc Input current: 11 mA @ 24 Vdc
27	DI2		
28	DI3		
29	DI4		
30	DI5		

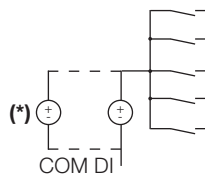
Figure 10.15: Description of XC22 connector

ATTENTION!

(*) External Power supply.

(**) For current, the S1 switch must be set ON.

10.3 INCREMENTAL ENCODER

Applications that require more speed or positioning accuracy, a speed feedback of the motor shaft by means of incremental encoder is required. The connection to the inverter is made through the XC9 connector (DB9) on the EBA function expansion board, or XC9 on EBB, or XC10 on EBC.

10.3.1 EBA/EBB Boards

When the EBA or EBB board is used, the selected encoder should have the following characteristics:

- Power supply voltage: 12 Vdc, less than 200 mA current consumption.

2 quadrature channels (90°) + zero pulse with complementary outputs (differential):

- Signals A, \bar{A} , B, \bar{B} , Z and \bar{Z} .
- "Linedriver" or "Push-Pull" output circuit type (12 V level).
- Electronic circuit isolated from the encoder frame.
- Recommended number of pulses per revolution: 1024 ppr.

Follow the recommendations below when mounting the encoder on the motor:

- Couple the encoder directly to the motor shaft (use a flexible coupling without torsional flexibility).
- Both the shaft and the metallic frame of the encoder must be electrically isolated from the motor (3 mm (0.119 in) minimum distance).
- Use high quality flexible couplings to prevent mechanical oscillation or backlash.

The electrical connections must be made with shielded cable, maintaining a minimum distance of about 25 cm (10 in) from other wires (power, control cables, etc.). If possible, install the encoder cable in a metallic conduit.

During the commissioning, it is necessary to program the control type, P202 = 4 (Vector with encoder), in order to operate with speed feedback via incremental encoder.

Refer to the [Chapter 11 DETAILED PARAMETER DESCRIPTION](#) on page 11-1 for more details on vector control.

The function expansion boards EBA and EBB have an encoder signal repeater, isolated and externally powered.

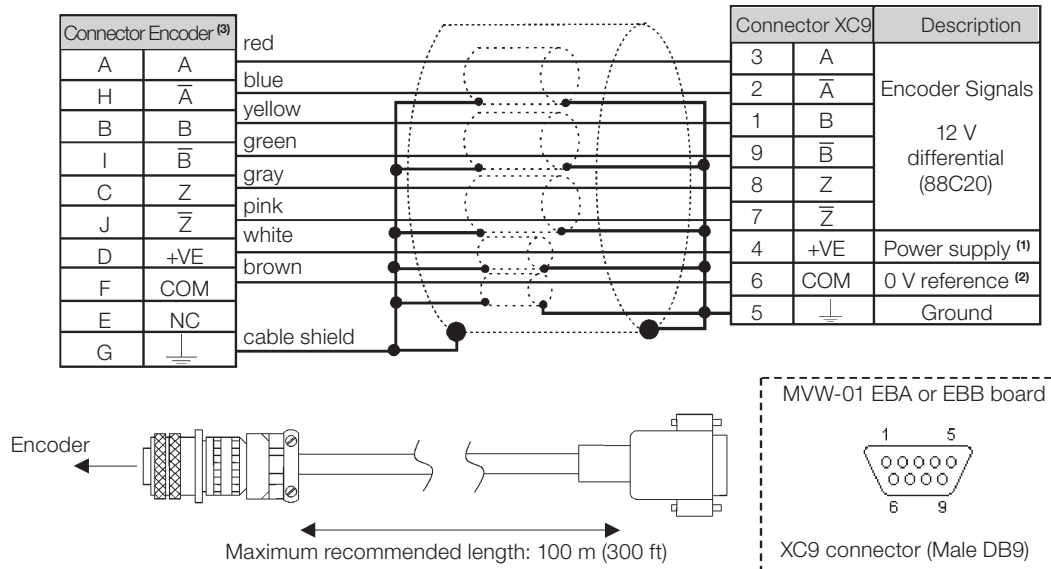

- (1) Power supply voltage 12 Vdc / 220 mA for encoder.
- (2) Referenced to ground via 1 μ F in parallel with 1 k Ω .
- (3) Connector pinout valid for HS35B Dynapar encoder. For other encoder models, verify the correct connection in order to meet the required sequence.

Figure 10.16: Encoder input

NOTE! The maximum allowed encoder signal frequency is 100 kHz.

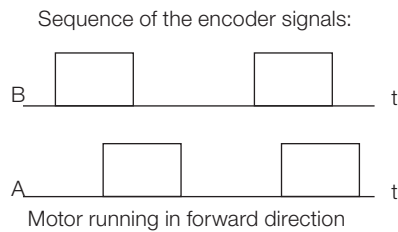

Figure 10.17: Encoder signals

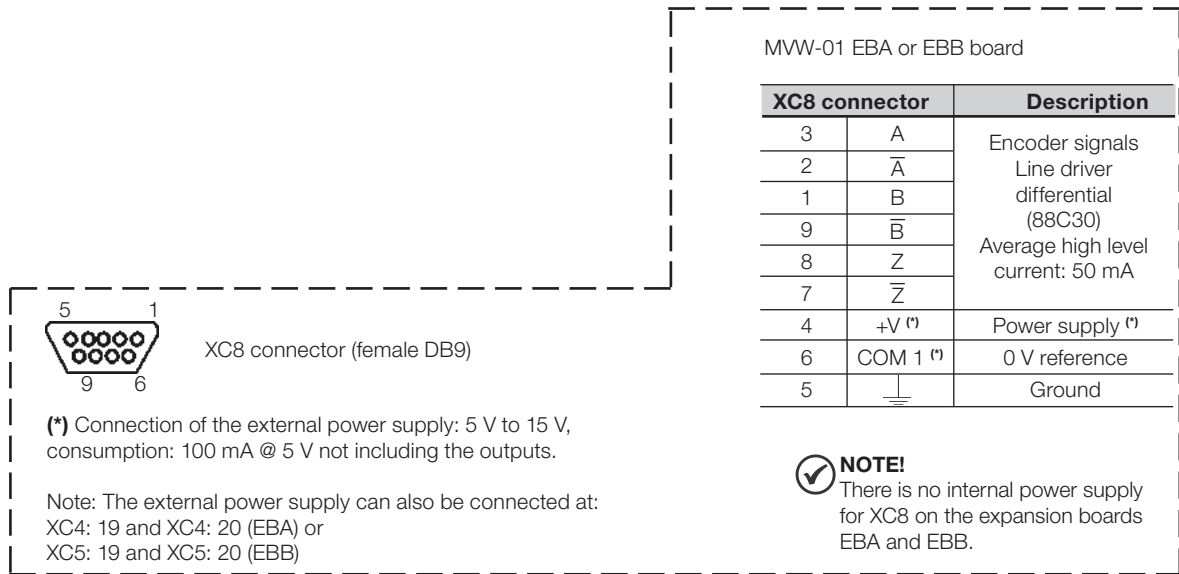

Figure 10.18: Encoder repeater

10.3.2 EBC1 Board

When the board EBC1 is used, the selected encoder should have the following characteristics:

- Power supply voltage: 5 V to 15 V.
- 2 quadrature channels (90°) with complementary outputs (differential): Signals A, \bar{A} , B and \bar{B} .
- "Linedriver" ou "Push-Pull" output circuit type (with identical level as the power supply voltage).
- Electronic circuit isolated from the encoder frame.
- Recommended number of pulses per revolution: 1024 ppr.

INSTALLATION OF THE EBC1 BOARD

The EBC board is installed directly on the MVC4 control board, secured by means of spacers and connected through the XC3 connector.

Mounting instructions:

1. De-energize the control rack.
2. Carefully insert the pins of the connector XC3 (EBC1) into the female connector XC3 of the MVC4 control board. Make sure that all pins fit in the XC3 connector.
3. Press on the board center (near to XC3) until the connector is completely inserted.
4. Secure the board to the 2 metallic spacers with the 2 provided bolts.

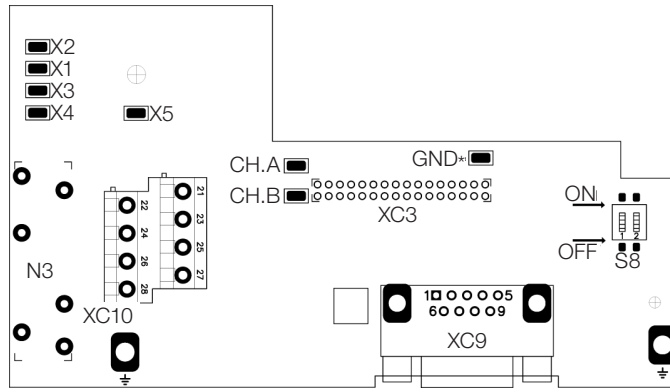

Figure 10.19: EBC1 board layout

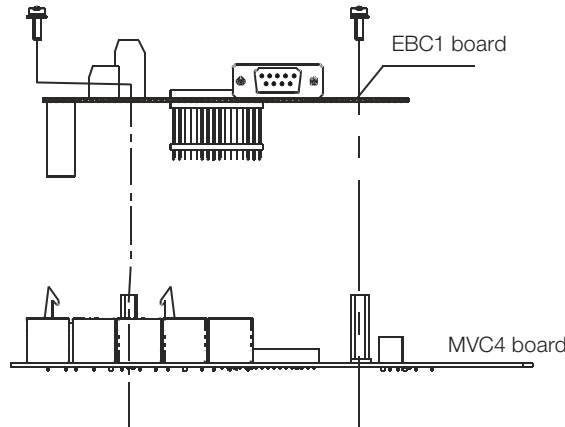

Figure 10.20: EBC1 board installation procedure

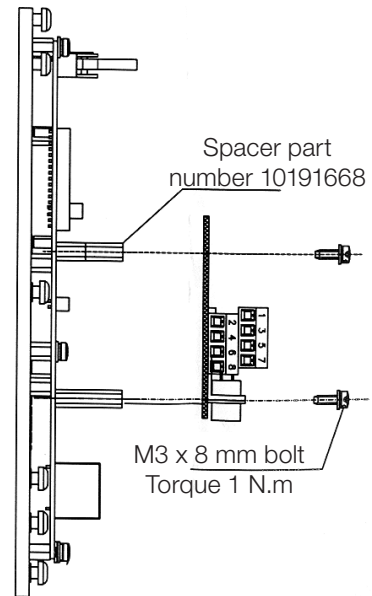
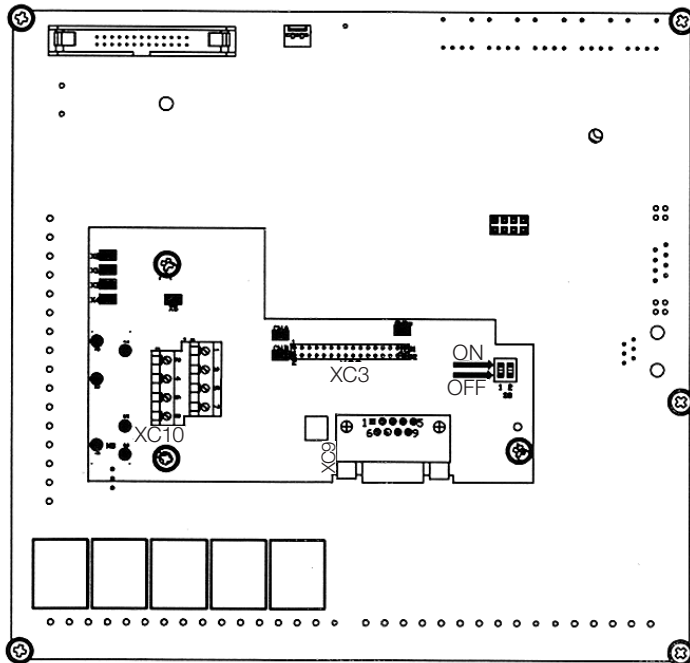

Figure 10.21: EBC1 board installation procedure

CONFIGURATIONS:

Table 10.9: EBC1 board configurations

Expansion Board	Power Supply	Encoder Voltage	Necessary Setting
EBC1.01	External 5 V	5 V	Commutate switch S8 to ON, see Figure 10.19 on page 10-16
	External 8 V to 15 V	8 V to 15 V	None
EBC1.02	Internal 5 V	5 V	None
EBC1.03	Internal 12 V	12 V	None

NOTE! The terminals XC10:22 and XC10:23 (see [Figure 10.19 on page 10-16](#)), should only be used for encoder supply, when the encoder power supply is not coming from the DB9 connector.

ENCODER MOUNTING:

Follow the recommendations below when mounting the encoder on the motor:

- Couple the encoder directly to the motor shaft (use a flexible coupling without torsional flexibility).
- Both the shaft and the metallic frame of the encoder must be electrically isolated from the motor (3 mm (0.119 in) minimum distance).
- Use high quality flexible couplings to prevent mechanical oscillation or backlash.

The electrical connections must be made with shielded cable, maintaining a minimum distance of about 25 cm (10 in) from other wires (power, control cables, etc.). If possible, install the encoder cable in a metallic conduit.

During the commissioning, it is necessary to program the control type, P202 = 4 (Vector with encoder), in order to operate with speed feedback via incremental encoder.

Refer to the [Chapter 11 DETAILED PARAMETER DESCRIPTION on page 11-1](#) for more details on vector control.

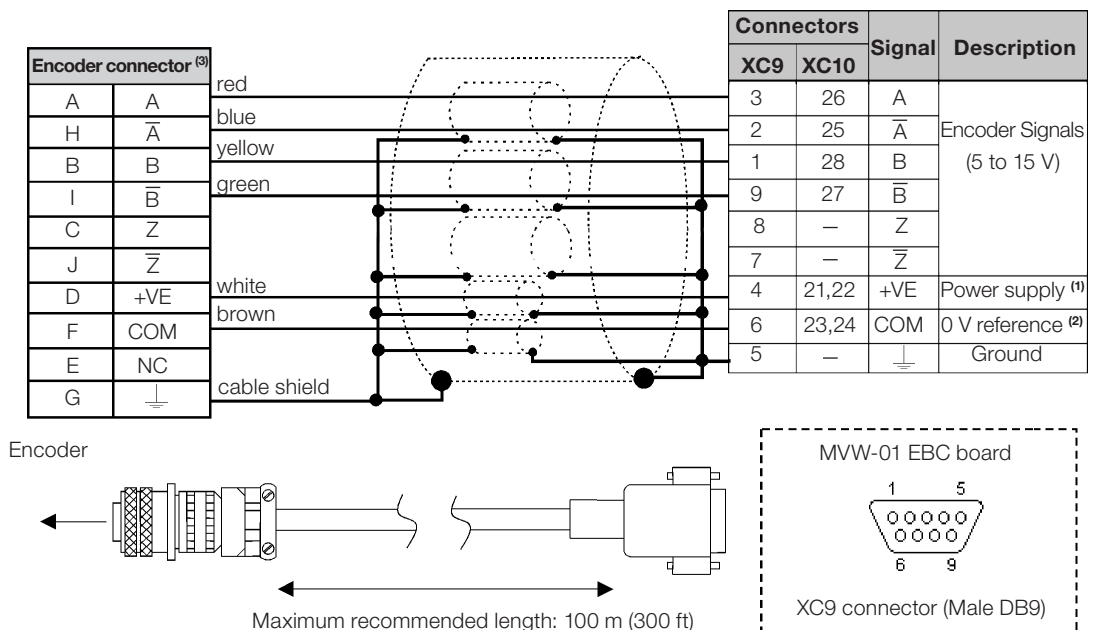

(1) External encoder power supply: 5 to 15 Vdc. Consumption of 40 mA plus the encoder consumption.

(2) 0 V reference of the power supply voltage.

(3) Connector pinout valid for HS35B Dynapar encoder. For other encoder models, verify the correct connection in order to meet the required sequence.

Figure 10.22: EBC1 encoder input



NOTE!

The maximum allowed encoder signal frequency is 100 kHz.

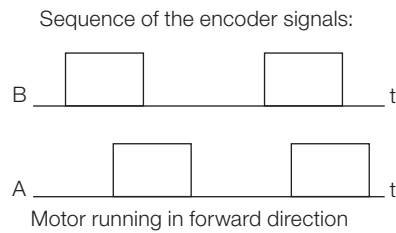

Figure 10.23: Encoder signals

10.4 SHORT UPS MODULE

The Short UPS module is an accessory that provides autonomy of approximately 500 ms in case of failure of the MVW-01 inverter auxiliary power supply. After the occurrence of the auxiliary power supply failure, the inverter remains operational, without faults, during 500 ms.

The module is based on a low voltage frequency inverter, CFW10 and an external capacitor bank, which ensure the energy supply to the power supplies during the specified period. A filter is added to the inverter output, necessary because of the characteristic of the fed loads.

The Short UPS feeds the following loads:

- PS1S power supply: responsible for feeding the gate drivers.
- PS24 power supply: responsible for feeding the control.
- General command: input circuit breaker supply and its undervoltage release.

10.4.1 CFW10 Inverter Parameterization

For the correct operation of the Short UPS module, the CFW10 inverter must be parameterized as shown below:

- P100 = 1.0 (Acceleration Time).
- P101 = 0.5 (Deceleration Time).
- P121 = 57.4 (Output Frequency).
- P206 = 3 (Auto-reset Time).
- P222 = 0 (Remote Speed Reference).
- P263 = 0 (DI1 Digital Input).
- P264 = 0 (DI2 Digital Input).
- P265 = 4 (DI3 Digital Input).
- P266 = 6 (DI4 Digital Input).
- P297 = 10 kHz (Switching Frequency).

10.5 MVC3 CONTROL BOARD CONNECTIONS

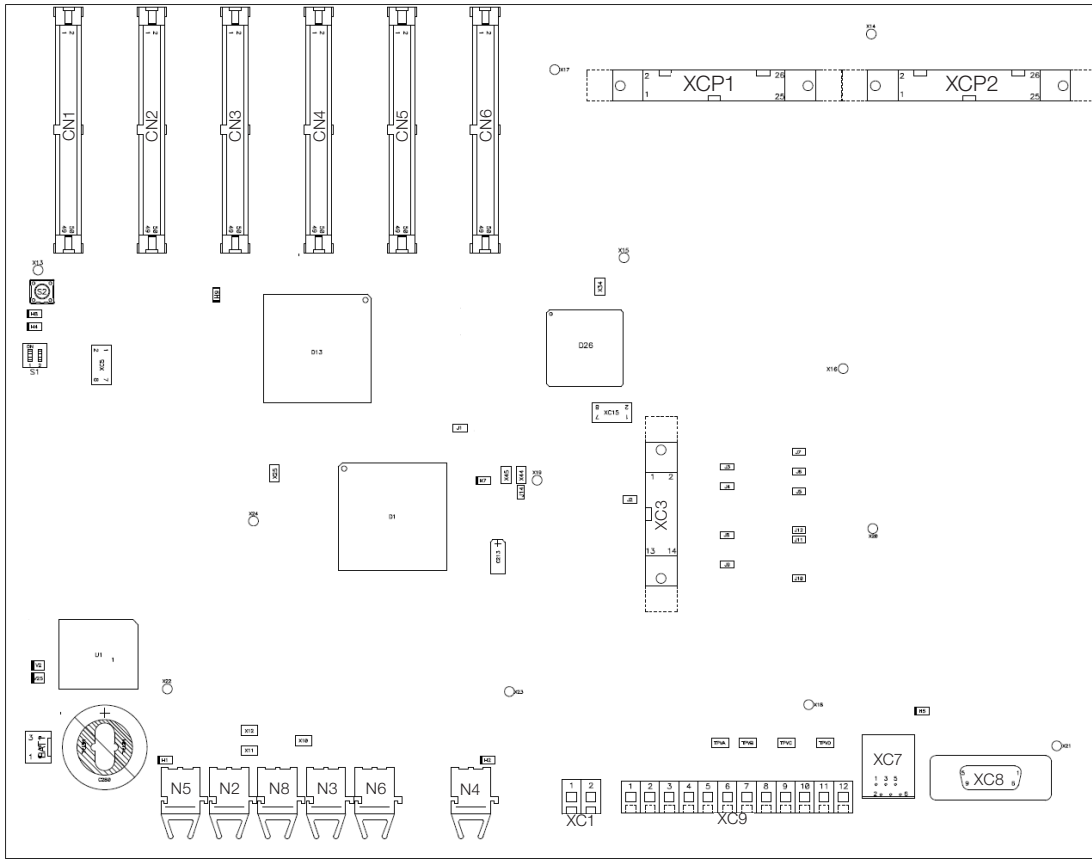

Figure 10.24: MVC3 Board Connections

Table 10.10: XC9 terminal strip connections

XC9 Terminal Strip	Factory Standard Function	Specifications
1	+5V4	Positive reference for potentiometer
2	AI1-	Analog input 1: No function
3	AI1+	
4	-4V7	Negative reference for potentiometer
5	AO1+	Analog output 1: Iu
6	AGND	
7	AO2+	Analog output 2: modulation index
8	AGND	
9	AO3+	Analog output 3: Iu
10	AGND	
11	AO4+	Analog output 4: modulation index
12	AGND	

Table 10.11: XC1 terminal strip description

XC1 Terminal Strip	Factory Standard Function	Specifications
1	AI2-	Analog input 2: No function
2	AI2+	

Note: AI2 is not implemented in the MVC1, only in the MVC3.



ATTENTION!

The I/Os described above are not isolated. Their utilization must be with galvanic isolators.

11 DETAILED PARAMETER DESCRIPTION

This chapter describes in detail all the parameters of the inverter. In order to simplify the explanation, the parameters have been grouped by characteristics and functions:

Read-only Parameters.	Variables that can be viewed on the display but cannot be changed by the user.
Regulation Parameters.	Programmable values used by the inverter functions.
Configuration Parameters.	They define the inverter characteristics, the functions to be executed, as well as the control board I/O functions.
Motor Parameters.	Used motor data, consisting of information from the motor nameplate.
Special Function Parameters.	It includes parameters related to special functions.

Symbols and definitions used in the following text:

- (1) Parameter can be changed only with the inverter disabled (motor stopped).
- (2) Values may change as a function of the motor parameters.
- (3) Values may change as a function of P412 (Tr Constant).
- (4) Values may change as a function of P296.
- (5) Values may change as a function of P295.
- (6) Values may change as a function of P320.

Torque current = is the total motor current component responsible for the torque development (in vector control mode).



Active current = is the total motor current component proportional to the active electric power consumed by the motor (in V/F control mode).

11.1 ACCESS AND READ ONLY PARAMETERS - P000 TO P099

Parameter	Range [Factory Setting] Unit	Description/Notes
P000 Access Parameter/ Password Setting For safety reasons, it will only be possible to change the password with the service HMI, which accompanies the product.	0 to 999 [0] -	<ul style="list-style-type: none"> ■ It allows the parameter contents modification. With the parameters adjusted according to the factory default [P200 = 1 (Active password)], it is necessary to program P000 = 5 in order to be able to change the parameter contents, i.e., the password is 5. ■ To change the password to another value (Password 1) proceed as follows: <ol style="list-style-type: none"> 1. Adjust P000 = 5 (current password) and P200 = 0 (Inactive password). 2. Press the key. 3. Change P200 to 1 (Active password). 4. Press again: the display shows P000. 5. Press again: the display shows 5 (current password value). 6. Adjust the new password (Password 1) with the and keys. 7. Press : the display shows P000. From this moment on the value adjusted above becomes the new password (Password 1). Therefore, in order to change parameters it will be necessary to program P000 = the new password (Password 1).

Parameter	Range [Factory Setting] Unit	Description/Notes
P001 Speed Reference	P133 to P134 [-] 1 rpm	<ul style="list-style-type: none"> Speed reference value presented in rpm (factory default). Regardless of the reference source. The displayed unit can be changed by means of P208 and P210.
P002 Motor Speed	0 to P134 [-] 1 rpm	<ul style="list-style-type: none"> It shows the motor speed in rpm (with a 0.5 s filter). The displayed unit can be changed by means of P208 and P210.
P003 Motor Current	0 to 3705 [-] 0.1 A(<1000)- 1 A(≥ 1000)	<ul style="list-style-type: none"> It indicates the inverter output current in Amperes (A). The current is calculated as a function of the motor torque and speed. When P621 > 0 (sinusoidal filter), the motor current is estimated as a function of the sinusoidal filter. With P621 > 0 the current measured in the inverter output can be seen in P011. It has Output Current Filter, P139. Default value P139 = 0.2 s. For line 2 x D and 2 x E, the HMI of the master rack indicates the sum of the currents of the slave inverters, and the HMIs of the slave racks indicate the current supplied to the motor for each inverter.
P004 DC Link Voltage	0 to 8000 [-] 1 V	<ul style="list-style-type: none"> It shows the DC link actual voltage in Volts (V). P004 is equal to the addition of P052 and P053 values. For line 2 x D and 2 x E, the HMI of the master rack indicates the highest voltage among the DC link of the slaves. The HMI of the slaves shows the present voltage on the DC link of each inverter.
P005 Motor Frequency	0.0 to 300.0 [-] 0.1 Hz	<ul style="list-style-type: none"> Inverter output frequency value in Hertz (Hz).
P006 Inverter Status	0 to 28 [-] -	<ul style="list-style-type: none"> It indicates the current inverter status according to the status machine diagram presented in the Figure 11.1 on page 11-4. <p>Inverter possible states:</p> <p>0 = 'Booting' indicates that the control board is waiting for the initialization end.</p> <p>1 = 'Sub' indicates that the inverter has insufficient voltage for operation (undervoltage), and does not accept the enabling command (inverter waiting for the pre-charge/power energization command).</p> <p>2 = 'Inv. Ready' indicates that the inverter is ready to be enabled.</p> <p>3 = 'Motor Mag.' indicates that the motor is being magnetized by DC current. This state lasts for two times the motor rotoric constant time (P412).</p> <p>4 = 'Motor Rdy.' indicates that the motor is magnetized and the inverter is waiting for the run command.</p> <p>5 = 'Up Ramp' indicates the motor is in the speed acceleration ramp.</p> <p>6 = 'Down Ramp' indicates that the motor is in the speed deceleration ramp.</p> <p>7 = 'In Ref.' indicates that the motor is rotating at the adjusted speed reference.</p> <p>8 = 'DC Break' indicates that the motor is stopping with DC braking.</p>

Parameter	Range [Factory Setting] Unit	Description/Notes
		<p>9 = 'Coast' indicates that the motor is coasting, without being driven by the inverter.</p> <p>10 = 'Ride Thro.' indicates that the inverter is operating during momentary line faults.</p> <p>11 = 'Flying St.' indicates that the inverter has received a command to start a spinning motor. This state persists until the inverter reaches the motor speed.</p> <p>12 = 'Test Mode' indicates that the inverter is in a transitory state to test mode or to self-tuning.</p> <p>13 = 'Inv. Test' indicates that the inverter is in a general test state.</p> <p>14 = 'Self-Comm.' Indicates that the inverter is performing the self-tuning, automatically measuring motor parameters.</p> <p>15 = 'Power Test' indicates that the inverter is testing power cabinet specific processes.</p> <p>16 = Fault.</p> <p>17 = Alarm.</p> <p>18 = 'Calibrat.' indicates that the inverter is in the feedback signal calibration process.</p> <p>19 = 'Hold' indicates that the inverter is in DC link regulation mode. Refer to the parameter P151 description.</p> <p>20 = 'I Limit' indicates that the inverter is in current limitation. Refer to the parameter P169 description.</p> <p>21 = 'I Fast Limit' indicates that the inverter is in fast current limitation.</p> <p>22 = 'Ride Thr 2' indicates Ride-Through without interruption. The state machine diagram can be seen in the Figure 11.1 on page 11-4, where the states indicated from 1 to 22 have their possible transitions indicated by the state changing arrows.</p> <p>23 = 'Hold 2'.</p> <p>24 = 'Sync' indicates that the inverter is synchronized with the line.</p> <p>25 = 'Fast Disab' indicates fast disable mode (HG = off) fast (MVC3).</p> <p>26 = 'In Sync' indicates that the inverter is trying to synchronize with the line.</p> <p>27 = 'Safety': indicates the inverter is in the safe stop mode.</p> <p>28 = 'WaitComm': indicates the inverter is waiting for communication between master and slaves.</p>

 **NOTE!** States that are not transitory, that is, states in which the inverter may remain for an undetermined period, are identified with an arrow that indicates the LOOP condition .

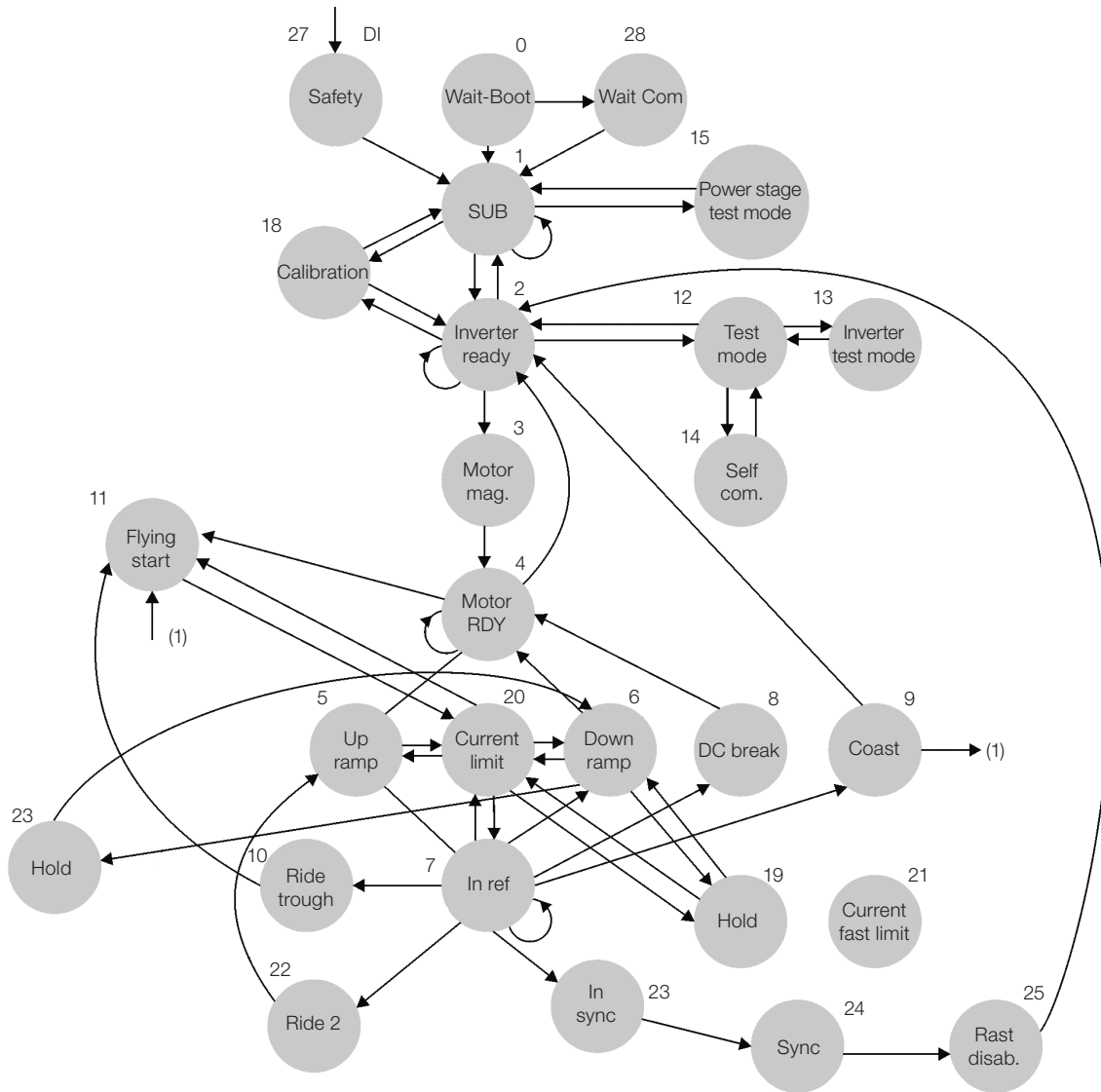



Figure 11.1: State machine

Parameter	Range [Factory Setting] Unit	Description/Notes
P007 Motor Voltage	0 to 8000 [-] 1 V	<ul style="list-style-type: none"> It indicates the inverter output voltage in Volts (V), based on the voltage and modulation index of the DC link.
P009 Motor Torque	0.0 to 250.0 [-] 0.1 %	<ul style="list-style-type: none"> It indicates the torque developed by the motor, calculated in the following way: $P009 = \frac{I_{tm} \times 100}{I_{tm\ nominal}}$ Where: I_{tm} = Actual motor torque current. Vector Mode: $I_{tm\ nominal}$ = Motor nominal torque current. Scalar Mode: $I_{tm\ nominal}$ = Inverter nominal torque current.

Parameter	Range [Factory Setting] Unit	Description/Notes
P010 Output Power	0 to 9999 [-] 1 kW	<ul style="list-style-type: none"> It indicates the inverter instantaneous output power in kW.
P011 Inverter Current  Parameter only visible with P621 = 1, 2 (sinusoidal filter active)	0 to 2600 [-] 0.1 A(<1000)- 1 A(≤ 1000)	<ul style="list-style-type: none"> It indicates the inverter output current, in ampères.
P012 Digital Inputs Status DI1 to DI10 (MVC4 and optional board)	A = Active I = Inactive [-] -	<ul style="list-style-type: none"> It indicates, on the HMIG, the state of the eight digital inputs of the control board MVC4 (DI1 to DI6, DI9, DI10) and of the two digital inputs of the optional board (DI7, DI8), by means of letters A (Active) and I (Inactive), in the following order: DI1, DI2, ... ,DI7, DI8, DI9, DI10

Parameter	Range [Factory Setting] Unit	Description/Notes
P013 Digital Outputs Status DO1, DO2 and Relays RL1, RL2, RL3, RL4 and RL5 (MVC4 and optional board)	A = Active I = Inactive [-] -	<ul style="list-style-type: none"> It indicates, on the IHMG, the state of the two digital outputs of the optional board, (DO1, DO2) and of the five relay outputs of the control board MVC4 by means of the numbers 1 (Active) and 0 (Inactive) in the following order: DO1, DO2, RL1, RL2, RL3, RL4, RL5.
P014 Last Error	0 to 255 [-] -	<ul style="list-style-type: none"> They indicate, respectively, the codes of the last, last but one, last but two and last but three error occurred. Recording sequence:
P015 Second Error	0 to 255 [-] -	Error → P014 → P015 → P016 → P017 → P060 → P061 → P062 → P063 → P064 → P065.
P016 Third Error	0 to 255 [-] -	<ul style="list-style-type: none"> To access more information about the error occurred, P067.
P017 Fourth Error	0 to 255 [-] -	
P018 Analog Input AI1' (MVC4 board)	0.0 to 100.0 [-] 0.1 %	<ul style="list-style-type: none"> They present the MVC4 control board analog inputs AI1 and AI2, EBB board AI3 and EBA board AI4 values, as a full scale percentage. The indicated values are those obtained after offset action and gain multiplication. Refer to the parameters P234 to P247 description. The analog input AI2 has a filter that differentiates it from the others (refer to P248).
P019 Analog Input AI2' (MVC4 board)	-100.0 to +100.0 [-] 0.1 %	
P020 Analog Input AI3' (EBB board)	-100.0 to +100.0 [-] 0.1 %	
P021 Analog Input AI4' (EBA board)	-100.0 to +100.0 [-] 0.1 %	
P022 MVC3 Board Temperature	0 to 100 [-] 1 °C	<ul style="list-style-type: none"> It indicates the MVC3 control board temperature, in Celsius degrees.
P023 MVC4 Software Version	XX.X [-] -	<ul style="list-style-type: none"> It indicates the software version contained in the MVC4 microcontroller memory.
P024 Value of the A/D Conversion of Analog Input AI4 (optional board)	LCD = -32768 to +32767 LED = 0 to FFFFH [-] -	<ul style="list-style-type: none"> It indicates the analog input AI4, which is located in the optional board, A/D conversion result. The HMI LCD indicates the conversion result in decimal, and the LED display in hexadecimal with negative values in two's complement.

Parameter	Range [Factory Setting] Unit	Description/Notes
P025 Iv Current A/D Conversion Value	0 to 4095 [-] -	<ul style="list-style-type: none"> P025, P026 and P027 indicate, respectively, the result of the A/D conversion, in module, of the phase currents V, W and U.
P026 Iw Current A/D Conversion Value	0 to 4095 [-] -	
P027 Iu Current A/D Conversion Value	0 to 4095 [-] -	
P028 Analog Input AI5' (MVC4 board)	0.0 to 100.0 [-] 0.1 %	<ul style="list-style-type: none"> It presents the MVC4 control board analog input AI5 value as a full scale percentage. The indicated value is obtained after offset action and gain multiplication. Refer to the parameters P721 to P724 description.
P029 Trace Function Status	0 to 3 [0] -	<ul style="list-style-type: none"> It indicates the state of the trace function. When trace is completed, as you press the key , the date and time at the moment of the trigger is presented.

Table 11.1: Trace function status

P029	Function
0	Inactive
1	Waiting for trigger
2	Trigger occurred
3	Trace completed

Parameter	Range [Factory Setting] Unit	Description/Notes
P030 Temperature Register CH1	0 to 240 [-] 1 °C	<ul style="list-style-type: none"> For these parameters to indicate the motor temperatures properly, the temperature control module (Tecsystem, Pextron) must be installed observing the recommendation contained in its manual. The communication between the Tecsystem and the MVW-01 control boards occurs through the Tecsystem-Busmod module and the MVC3 SCI1 serial channel. The parameter P315 must be programmed so that the SCI1 channel be used with the Tecsystem module (P315 = 1) or Pextron (P315 = 2). The overtemperature fault and alarm levels are directly configured on the temperature control module according to its manual. The configuration of serial transmission of the module must be set as follows: Tecsystem: Baud rate: 19200 bps (SW1.dip1 = 1 / SW1.dip2 = 1). Parity: Even (SW1.dip3 = 1 / SW1.dip4 = 1). Slave address: 1 (SW2.dip7 to dip1 = 0 / SW2.dip0 = 1). Pextron: Baud rate: 19200 bps (P028 = 19.2). Parity: Even (P030 = 2). Slave address: 1 (P029 = 1).
P031 Temperature Register CH2	0 to 240 [-] 1 °C	
P032 Temperature Register CH3	0 to 240 [-] 1 °C	
P033 Temperature Register CH4	0 to 240 [-] 1 °C	
P034 Temperature Register CH5	0 to 240 [-] 1 °C	
P035 Temperature Register CH6	0 to 240 [-] 1 °C	
P036 Temperature Register CH7	0 to 240 [-] 1 °C	
P037 Temperature Register CH8	0 to 240 [-] 1 °C	
These parameters are only visible on the display when P315 = 1 (Tecsystem) or P315 = 2 (Pextron)		
P040 PID Process Variable	0 to P528 [-] %	<ul style="list-style-type: none"> It indicates, in percentage (factory default), the process variable used as the PID feedback. The variable unit can be changed through the parameters P530, P531 and P532. The scale can be changed through P528 and P529. Refer to the detailed description at Section 12.2 PID Regulator on page 12-6.
These parameters are only visible on the display when P203 = 1 or 3		

Parameter	Range [Factory Setting] Unit	Description/Notes																		
P041 Active Redundant Ventilation Set	0 to 7 [0] -	<ul style="list-style-type: none"> It indicates the status of the redundant ventilation. P041 is only accessible when the redundant ventilation is programmed (P140 > 0). <p style="text-align: center;"><i>Table 11.2: Redundant ventilation set</i></p> <table border="1" style="margin-left: auto; margin-right: auto;"> <thead> <tr> <th>Status</th> <th>Status Description</th> </tr> </thead> <tbody> <tr> <td>0</td> <td>Set A is active</td> </tr> <tr> <td>1</td> <td>Set B is active</td> </tr> <tr> <td>2</td> <td>Set A is active - Set B has failed</td> </tr> <tr> <td>3</td> <td>Set B is active - Set A has failed</td> </tr> <tr> <td>4</td> <td>Set A is active - Sets A and B have failed</td> </tr> <tr> <td>5</td> <td>Set B is active - Sets A and B have failed</td> </tr> <tr> <td>6</td> <td>Set A automatic test</td> </tr> <tr> <td>7</td> <td>Set B automatic test</td> </tr> </tbody> </table> <ul style="list-style-type: none"> The states 4 and 5 occur when both the sets have failed. In this case the inverter must be powered off and the defective fans must be repaired or replaced (followed by a reset of the redundant ventilation function, refer to P140), otherwise successive ventilation set changes will occur, until the situation is normalized. 	Status	Status Description	0	Set A is active	1	Set B is active	2	Set A is active - Set B has failed	3	Set B is active - Set A has failed	4	Set A is active - Sets A and B have failed	5	Set B is active - Sets A and B have failed	6	Set A automatic test	7	Set B automatic test
Status	Status Description																			
0	Set A is active																			
1	Set B is active																			
2	Set A is active - Set B has failed																			
3	Set B is active - Set A has failed																			
4	Set A is active - Sets A and B have failed																			
5	Set B is active - Sets A and B have failed																			
6	Set A automatic test																			
7	Set B automatic test																			
P042 Energized Hours Counter	LCD = 0 to 65530 [-] 1 h	<ul style="list-style-type: none"> It indicates the total number of hours that the inverter remained powered. This value remains stored even when the inverter is turned OFF. 																		
P043 Enabled Hours Counter	0 to 6553 [-] 0.1 h (<999.9) 1 h (>1000)	<ul style="list-style-type: none"> It indicates the total number of hours that the inverter remained enabled. It indicates up to 6553 hours; then it returns to zero. Setting P204 = 3, the value of parameter P043 goes to zero. This value is maintained, even when the inverter is powered down. 																		
P044 Counter (MWh)	0 to 11930 [-] 1 MWh	<ul style="list-style-type: none"> It indicates the energy consumed by the motor. It counts up to 11930 MWh, and then it rolls over to zero. Setting P204 = 4, the value of P044 goes to zero. This value is maintained, even when the inverter is powered down. 																		
P045 HMI Software Version	XX.X [-] -	<ul style="list-style-type: none"> It indicates the software version contained in the Graphic HMI microcontroller memory. 																		
P046 Junction Temperature	-20.0 to +200.0 [-] 0.1 °C	<ul style="list-style-type: none"> It indicates the theoretical junction temperature of the IGBTs. 																		







Parameter	Range [Factory Setting] Unit	Description/Notes
P047 Temperature on the Power Arm of Phase U of Parallel Inverter A	-20.0 to +200.0 [-] 0.1 °C	<ul style="list-style-type: none"> ■ P047, P048 and P049 indicate, respectively, the temperature, in degrees Celsius, on the power arm of phases U, V and W of the parallel inverter A.
P048 Temperature on the Power Arm of Phase V of Parallel Inverter A	-20 to +200.0 [-] 0.1 °C	
P049 Temperature on the Power Arm of Phase W of Parallel Inverter A	-20 to +200.0 [-] 0.1 °C	
P050 Temperature on the Arm of the Braking Circuit of Parallel Inverter A	-20.0 to +200.0 [-] 0.1 °C	<ul style="list-style-type: none"> ■ It indicates the temperature on the arm of the braking circuit in degrees Celsius. ■ When the braking circuit (optional) does not exist, parameter P050 indicates 0.0 °C.
P051 Temperature on the Parallel Rectifier	-20.0 to +200.0 [-] 0.1 °C	<ul style="list-style-type: none"> ■ It indicates the temperature on the heatsink of the input rectifier in degrees Celsius.
P052 Negative DC Link Voltage	0 to 8000 [-] 1 V	<ul style="list-style-type: none"> ■ It indicates the positive DC link actual voltage, in Volts.
P053 Positive DC Link Voltage	0 to 8000 [-] 1 V	<ul style="list-style-type: none"> ■ It indicates the positive DC link actual voltage, in Volts.
P055 Temperature on the Power Arm of Phase U	-20.0 to +200.0 [-] 0.1 °C	<ul style="list-style-type: none"> ■ P055, P056 and P057 indicate, respectively, the temperature in Celsius degrees at the power arms of the phases U, V and W.
P056 Temperature on the Power Arm of Phase V	-20.0 to +200.0 [-] 0.1 °C	
P057 Temperature on the Power Arm of Phase W	-20.0 to +200.0 [-] 0.1 °C	



Parameter	Range [Factory Setting] Unit	Description/Notes
P058 Temperature on the Arm of the Braking Circuit	-20.0 to +200.0 [-] 0.1 °C	<ul style="list-style-type: none"> It indicates the braking arm temperature, in Celsius degrees. When the braking arm (optional) is not present, P058 shows 0.0 °C.
P059 Rectifier 1 Temperature (standard)	-20.0 to +200.0 [-] 0.1 °C	<ul style="list-style-type: none"> It indicates the input rectifier heatsink temperature, in Celsius degrees.
P060 Fifth Error	0 to 255 [-] -	<ul style="list-style-type: none"> These parameters indicate the error code of the fifth, sixth, seventh, eighth, ninth and tenth errors, respectively. Recording sequence: Error → P014 → P015 → P016 → P017 → P060 → P061 → P062 → P063 → P064 → P065. To access more information about the error occurred, see P067.
P061 Sixth Error	0 to 255 [-] -	
P062 Seventh Error	0 to 255 [-] -	
P063 Eighth Error	0 to 255 [-] -	
P064 Ninth Error	0 to 255 [-] -	
P065 Tenth Error	0 to 255 [-] -	
P066 Software Version of the Board MVC3	XX.X [-] -	<ul style="list-style-type: none"> It indicates the software version contained in the microcontroller memory located on the control board MVC3.
P067 Error Log	1 to 100 [-] -	<ul style="list-style-type: none"> It keeps the record of the last 100 errors (alarms/faults) occurred in the inverter. To access the error log, press the key and then use the and keys to change the indication of the corresponding error. The last error occurred (the most recent error event) is represented by the error register 1, and the hundredth error occurred (the oldest error event) is represented by register 100. The information presented in the register includes the error number (e.g. A/F 087), the inverter state at the moment of the error (e.g.: Inv. Ready) and date/time at the moment the error occurred. For instance, in order to access the 8th last occurred error, proceed in the following manner: <ul style="list-style-type: none"> Access the parameter P067. Press the key. Use the and keys to access the eighth record.





Parameter	Range [Factory Setting] Unit	Description/Notes
P070 Digital Input Status DI1 to DI16 (MVC3 board)	A = Active I = Inactive [-] -	<ul style="list-style-type: none"> It indicates on the HMIG the state of the 16 digital inputs of the control board MVC3 (DI1 to DI16), and the state of each input is considered a bit, in the following order: DI1, DI2, ... , DI15, DI16.
P071 Relay Output Status RL1 to RL8 (MVC3 board)	A = Active I = Inactive [-] -	<ul style="list-style-type: none"> It indicates on the HMIG the state of the 8 relay outputs of the control board MVC3, and the state of each input is considered a bit, in the following order: RL1, RL2, ... , RL7, RL8.
P072 Vab Input Voltage (sinusoidal signal)	-8000 to +8000 [-] 1 Vac	<ul style="list-style-type: none"> It indicates the line voltage between phases a and b (Vab) at the input inverter, in Volts.
P073 Vcb Input Voltage (sinusoidal signal)	-8000 to +8000 [-] 1 Vac	<ul style="list-style-type: none"> It indicates the line voltage between phases c and b (Vcb) at the input inverter, in Volts.
P074 Voltage Modulus of Input Transformer Secondary	0 to 3750 [-] 1 Vac	<ul style="list-style-type: none"> It indicates the voltage modulus of the input transformer secondary star winding, in Volts.
P075 Medium Point to Ground Voltage	0.0 to 100.0 [-] 0.1 %	<ul style="list-style-type: none"> It indicates the voltage between the DC link medium point (PM) and the ground (GND), in %. Note: 100 % is equivalent to the line voltage of the an input ransformer secondary winding. Except for modules with 18-pulse rectifier or line 6.9 kV.
P076 Overload I x t	0.0 to 150.0 [-] 0.1 %	<ul style="list-style-type: none"> It indicates the percentage of the overload given by parameters P156, P157 and P158. Motor Overload fault (F072) trips when P076 reaches 100 %.
P077 Field Current	0 to 999.9 [-] 1 A	<ul style="list-style-type: none"> Reading parameter of the field current of the synchronous motor.
P078 Brushless Field Voltage	0 to 9999 [-] 1 V	<ul style="list-style-type: none"> Field voltage of the brushless synchronous motor. Function not implemented in this software version.
P079 Position of the Motor Shaft	0 to 360.0° [-]	<ul style="list-style-type: none"> Position of the motor shaft. The HMIG only presents the position in ° within the same turn. <p>Note:</p> <ul style="list-style-type: none"> 8 most significant bits = number of turns. 8 bits least significant bits = position within the same turn. Resolution = (1/256) x 360°.



This parameter is only visible with P950 ≥ 1

Parameter	Range [Factory Setting] Unit	Description/Notes
P080 Date	dd/mm/aa [-] 1 day	<ul style="list-style-type: none"> ■ It indicates on the HMIG the present date in the format "dd/mm/aa". ■ Procedure to adjust the date: <ol style="list-style-type: none"> 1. Press the  key. 2. Use keys  and  to set the desired value of the new date. ■ It indicates on the LED display of the HMI the present year in the format "aaaa". ■ The value of this parameter is set at the factory to indicate the present date. ■ The maximum supported date is 2099. Only lower values must be programmed.
P081 Hour	hh:mm:ss [-] 10 s	<ul style="list-style-type: none"> ■ It indicates on the HMIG the present time in the format "hh:mm:ss". ■ It indicates on the HMIG the seconds of the present time in the format "ss". ■ Procedure to adjust the hour: <ol style="list-style-type: none"> 1. Press the  key. 2. Use the keys  and  to set the desired value of the new time. ■ This parameter is adjusted at the factory to show the actual time. ■ The hours use the format from 0 to 24 h. It is not possible to select another format. ■ The time setting is done in steps of ten seconds.

Parameter	Range [Factory Setting] Unit	Description/Notes
P082 Temperature on the Power Arm of Phase U of Inverter B	-20.0 to +200.0 [-] 0.1 °C	<ul style="list-style-type: none"> ■ P082, P083 and P084 indicate, respectively, the temperature in degrees Celsius on the power arm of phases U, V and W of inverter B. ■ P085, P086 and P087 indicate, respectively, the temperature in degrees Celsius on the power arm of phases U, V and W of the parallel inverter B.
P083 Temperature on the Power Arm of Phase V of Inverter B	-20.0 to +200.0 [-] 0.1 °C	
P084 Temperature on the Power Arm of Phase W of Inverter B	-20.0 to +200.0 [-] 0.1 °C	
P085 Temperature on the Power Arm of Phase U of Parallel Inverter B	-20.0 to +200.0 [-] 0.1 °C	
P086 Temperature on the Power Arm of Phase V of Parallel Inverter B	-20.0 to +200.0 [-] 0.1 °C	
P087 Temperature on the Power Arm of Phase W of Parallel Inverter B	-20.0 to +200.0 [-] 0.1 °C	
P088 Temperature on the Rectifier 2	-20.0 to +200.0 [-] 0.1 °C	
 Parameter only visible in line MVW-01 - 5L		
P089 Temperature on the Rectifier 3	-20.0 to +200.0 [-] 0.1 °C	<ul style="list-style-type: none"> ■ It indicates the temperature on the heatsink of input rectifier 3, in degrees Celsius.
 Parameter only visible in line MVW-01 - 5L		

Parameter	Range [Factory Setting] Unit	Description/Notes
<p>P092 Voltage on the Negative DC Link of Phase V</p> <p> Parameter only visible in line MVW-01 - 5L</p>	<p>0 to 8000 [-] 1 V</p>	<ul style="list-style-type: none"> ■ It indicates the voltage on the negative DC link on phase V, in volts.
<p>P093 Voltage on the Positive DC Link of Phase V</p> <p> Parameter only visible in line MVW-01 - 5L</p>	<p>0 to 8000 [-] 1 V</p>	<ul style="list-style-type: none"> ■ It indicates the voltage on the positive DC link on phase V, in volts.
<p>P094 Voltage on the Negative DC Link of Phase W</p> <p> Parameter only visible in line MVW-01 - 5L</p>	<p>0 to 8000 [-] 1 V</p>	<ul style="list-style-type: none"> ■ It indicates the voltage on the negative DC link on phase W, in volts.
<p>P095 Voltage on the Positive DC Link of Phase W</p> <p> Parameter only visible in line MVW-01 - 5L</p>	<p>0 to 8000 [-] 1 V</p>	<ul style="list-style-type: none"> ■ It indicates the voltage on the positive DC link on phase W, in volts.

11.2 REGULATION PARAMETERS - P100 TO P199

Parameter	Range [Factory Setting] Unit	Description/Notes
P100 Acceleration Time	0.0 to 999.0 [100.0] 0.1 s (<99.9) - 1 s (>99.9)	<ul style="list-style-type: none"> 0.0 s setting means no use of ramp, i.e., the application of a voltage step (0 to 100 %) to the motor. They define the times to accelerate linearly from 0 up to the maximum speed (P134) and decelerate linearly from the maximum speed down to 0. The commutation to the 2nd Ramp can be done through one of the digital inputs from DI3 to DI10, if programmed for the 2nd Ramp function. Refer to P265 to P272.
P101 Deceleration Time	0.0 to 999.0 [180.0] 0.1 s (<99.9) - 1 s (>99.9)	
P102 Acceleration Time 2 nd Ramp	0.0 to 999.0 [100.0] 0.1 s (<99.9) - 1 s (>99.9)	
P103 Deceleration Time 2 nd Ramp	0.0 to 999.0 [180.0] 0.1 s (<99.9) - 1 s (>99.9)	

P104 S Ramp	0.0 to 100.0 [0.0] 0.1 %	<ul style="list-style-type: none"> It defines the S Ramp percentage used during accelerations and decelerations. The Figure 11.2 on page 11-16 allows a better understanding.
-----------------------	----------------------------------	--

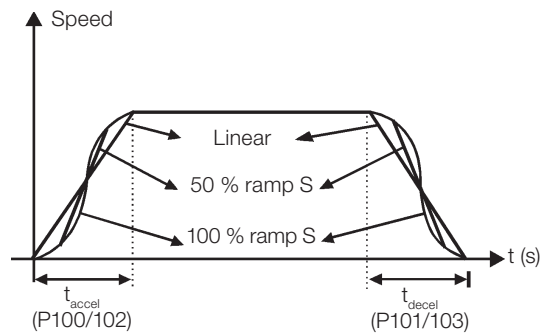

Figure 11.2: S or linear ramp

$$P104 = \frac{t_{ramps}}{t_{acel}} \cdot 100 \% = \frac{(t_{accel} - t_{linear})}{t_{acel}} \cdot 100 \% , \text{ in the accelerations, or}$$

$$P104 = \frac{t_{ramps}}{t_{decel}} \cdot 100 \% = \frac{(t_{decel} - t_{linear})}{t_{decel}} \cdot 100 \% , \text{ in the decelerations.}$$

Where:

t_{accel} = acceleration time, defined by P100 or P102.

t_{decel} = deceleration time, defined by P101 or P103.

t_{ramps} = time of S ramp.

t_{linear} = time of linear ramp.

- A setting of 0.0 % means inactive function and only the linear ramp will be used.
- The S ramp reduces the mechanical shocks during accelerations and decelerations.

Parameter	Range [Factory Setting] Unit	Description/Notes						
<p>P119 Reactive Power reference of the Power Factor Control</p>	<p>-99.99 to 99.99 [-] 0.01 %</p>	<ul style="list-style-type: none"> Reference for reactive current of the synchronous motor. -99.99 %: reference of the capacitive reactive current equal to 99.99 % of the inverter current (FP = 0 capacitive). 0 %: reference of null reactive current. +99.99 %: reference of inductive reactive current equal to 99.99 % of the inverter current (FP = 0 inductive). <p><i>Figure 11.3: Analog signal of the field current to be used in the motor</i></p>						
<p>P120 Speed Reference Backup</p>	<p>0 or 1 [1] -</p>	<ul style="list-style-type: none"> It defines whether the Speed Reference Backup is active (1) or inactive (0). If P120 = inactive, then the inverter will not save the reference when it is disabled, i.e., when the inverter is enabled again the speed reference will be the minimum speed. This backup function is applied only to the reference via HMI. <p><i>Table 11.3: Backup function</i></p> <table border="1"> <thead> <tr> <th>P120</th> <th>Backup</th> </tr> </thead> <tbody> <tr> <td>0</td> <td>Inactive</td> </tr> <tr> <td>1</td> <td>Active</td> </tr> </tbody> </table>	P120	Backup	0	Inactive	1	Active
P120	Backup							
0	Inactive							
1	Active							
<p>P121 Keypad Speed Reference and </p> <p>P122 ⁽²⁾ JOG or JOG+ Speed Reference</p> <p>P123 ⁽²⁾ JOG- Speed Reference</p>	<p>P133 to P134 [90] 1 rpm</p> <p>0 to P134 [150] 1 rpm</p> <p>0 to P134 [150] 1 rpm</p>	<ul style="list-style-type: none"> Keys and active: P221 = 0 or P222 = 0. The value of P121 is maintained in the last value set (backup) even disabling or powering down the inverter [with P120 = 1 (Active)]. Activation of the JOG function. <p><i>Table 11.4: JOG command selected by digital input</i></p> <table border="1"> <thead> <tr> <th>JOG Key</th> <th>DI1 to DI3 Digital Inputs (P225 = 2 and/or P228 = 2)</th> </tr> </thead> <tbody> <tr> <td>P225 = 1 and/or P228 = 1</td> <td>DI3 - P265 = JOG or DI4 - P266 = JOG or DI5 - P267 = JOG or DI6 - P268 = JOG or DI7 - P269 = JOG or DI8 - P270 = JOG or DI9 - P271 = JOG or DI10 - P272 = JOG</td> </tr> </tbody> </table> <ul style="list-style-type: none"> During the JOG command, the motor accelerates to the value defined at P122, following the acceleration ramp setting. The direction of rotation is defined by the direction of rotation function (P223 or P226). JOG can only be activated when the motor is disabled (stopped). JOG+ function activation. 	JOG Key	DI1 to DI3 Digital Inputs (P225 = 2 and/or P228 = 2)	P225 = 1 and/or P228 = 1	DI3 - P265 = JOG or DI4 - P266 = JOG or DI5 - P267 = JOG or DI6 - P268 = JOG or DI7 - P269 = JOG or DI8 - P270 = JOG or DI9 - P271 = JOG or DI10 - P272 = JOG		
JOG Key	DI1 to DI3 Digital Inputs (P225 = 2 and/or P228 = 2)							
P225 = 1 and/or P228 = 1	DI3 - P265 = JOG or DI4 - P266 = JOG or DI5 - P267 = JOG or DI6 - P268 = JOG or DI7 - P269 = JOG or DI8 - P270 = JOG or DI9 - P271 = JOG or DI10 - P272 = JOG							

Parameter	Range [Factory Setting] Unit	Description/Notes																																													
		<p><i>Table 11.5: JOG+ command selection</i></p> <table border="1"> <thead> <tr> <th>Digital Inputs</th> <th>Parameters</th> </tr> </thead> <tbody> <tr> <td>DI3 to DI10</td> <td>P265 to P272 = JOG+</td> </tr> </tbody> </table> <ul style="list-style-type: none"> JOG- function activation: <p><i>Table 11.6: JOG- command selection</i></p> <table border="1"> <thead> <tr> <th>Digital Inputs</th> <th>Parameters</th> </tr> </thead> <tbody> <tr> <td>DI3 to DI10</td> <td>P265 to P272 = JOG-</td> </tr> </tbody> </table> <ul style="list-style-type: none"> During the JOG+ or JOG- commands the values of P122 or P123 are, respectively, added to or subtracted from the speed reference, to generate the total reference - refer to the Figure 11.26 on page 11-48. 	Digital Inputs	Parameters	DI3 to DI10	P265 to P272 = JOG+	Digital Inputs	Parameters	DI3 to DI10	P265 to P272 = JOG-																																					
Digital Inputs	Parameters																																														
DI3 to DI10	P265 to P272 = JOG+																																														
Digital Inputs	Parameters																																														
DI3 to DI10	P265 to P272 = JOG-																																														
P124 ⁽²⁾ Multispeed Reference 1	P133 to P134 [90] 1 rpm	<ul style="list-style-type: none"> The parameters from P124 to P131 will only be shown when P221 = 8 and/or P222 = 8 (Multispeed). Multispeed is used when up to 8 fixed pre-programmed speeds are required. 																																													
P125 ⁽²⁾ Multispeed Reference 2	P133 to P134 [300] 1 rpm	<ul style="list-style-type: none"> When just 2 or 4 speeds are required, any combination of inputs between DI4, DI5 and DI6 can be used. Verify the speed reference parameters according to the used DIs. 																																													
P126 ⁽²⁾ Multispeed Reference 3	P133 to P134 [600] 1 rpm	<ul style="list-style-type: none"> The inputs programmed for other functions must be considered as 0 V in the Table 11.8 on page 11-18. 																																													
P127 ⁽²⁾ Multispeed Reference 4	P133 to P134 [900] 1 rpm	<ul style="list-style-type: none"> The stability of the fixed pre-programmed references and their immunity against electric noises (isolated digital inputs) are advantages of the Multispeed function. 																																													
P128 ⁽²⁾ Multispeed Reference 5	P133 to P134 [1200] 1 rpm	<ul style="list-style-type: none"> The Multispeed function is active only when P221 or P222 = Multispeed. 																																													
P129 ⁽²⁾ Multispeed Reference 6	P133 to P134 [1500] 1 rpm	<ul style="list-style-type: none"> It allows control of the output speed by associating the values defined in the parameters P124 to P131 to the logic combination of the digital inputs. <p><i>Table 11.7: Multispeed function selected by digital input</i></p> <table border="1"> <thead> <tr> <th>Enabled Digital Input</th> <th>Programming</th> </tr> </thead> <tbody> <tr> <td>4</td> <td>P266 = 7</td> </tr> <tr> <td>5</td> <td>P267 = 7</td> </tr> <tr> <td>6</td> <td>P268 = 7</td> </tr> </tbody> </table>	Enabled Digital Input	Programming	4	P266 = 7	5	P267 = 7	6	P268 = 7																																					
Enabled Digital Input	Programming																																														
4	P266 = 7																																														
5	P267 = 7																																														
6	P268 = 7																																														
P130 ⁽²⁾ Multispeed Reference 7	P133 to P134 [1800] 1 rpm	<p><i>Table 11.8: Multispeed references</i></p> <table border="1"> <thead> <tr> <th colspan="3">8 Speeds</th> <th rowspan="3">Speed Reference</th> </tr> <tr> <th colspan="3">4 Speeds</th> </tr> <tr> <th colspan="2">2 Speeds</th> <th rowspan="2">DI4</th> </tr> <tr> <th>DI6</th> <th>DI5</th> <th>DI4</th> </tr> </thead> <tbody> <tr> <td>0</td> <td>0</td> <td>0</td> <td>P124</td> </tr> <tr> <td>0</td> <td>0</td> <td>1</td> <td>P125</td> </tr> <tr> <td>0</td> <td>1</td> <td>0</td> <td>P126</td> </tr> <tr> <td>0</td> <td>1</td> <td>1</td> <td>P127</td> </tr> <tr> <td>1</td> <td>0</td> <td>0</td> <td>P128</td> </tr> <tr> <td>1</td> <td>0</td> <td>1</td> <td>P129</td> </tr> <tr> <td>1</td> <td>1</td> <td>0</td> <td>P130</td> </tr> <tr> <td>1</td> <td>1</td> <td>1</td> <td>P131</td> </tr> </tbody> </table>	8 Speeds			Speed Reference	4 Speeds			2 Speeds		DI4	DI6	DI5	DI4	0	0	0	P124	0	0	1	P125	0	1	0	P126	0	1	1	P127	1	0	0	P128	1	0	1	P129	1	1	0	P130	1	1	1	P131
8 Speeds			Speed Reference																																												
4 Speeds																																															
2 Speeds		DI4																																													
DI6	DI5		DI4																																												
0	0	0	P124																																												
0	0	1	P125																																												
0	1	0	P126																																												
0	1	1	P127																																												
1	0	0	P128																																												
1	0	1	P129																																												
1	1	0	P130																																												
1	1	1	P131																																												
P131 ⁽²⁾ Multispeed Reference 8	P133 to P134 [1650] 1 rpm																																														

Parameter	Range [Factory Setting] Unit	Description/Notes
<p>P132 Maximum level of Overspeed</p> <p> This parameter is only visible in the display(s) when P202 = 3 or 4 (Vector Control)</p>	<p>0 to 100 [10] 1 %</p>	<ul style="list-style-type: none"> ■ When the actual speed exceeds the value of P134 + P132 for over 20 ms, the MVW-01 will disable the pulses of the PWM and it will indicate fault F112. ■ The setting of P132 is a percentage valued of P134. ■ When setting P132 = 100 % the function will be disabled.

Parameter	Range [Factory Setting] Unit	Description/Notes
-----------	------------------------------------	-------------------

P133 ⁽²⁾
Minimum Speed
Reference
0 to (P134-1)
[90]
1 rpm

P134 ⁽²⁾
Maximum Speed
Reference
(P133+1) to
(3.4xP402)
[1800]
1 rpm

- They define the minimum and the maximum motor speed reference values. They are valid for any type of reference signal.
- For more details about the actuation of P133 refer to P233 (Analog Inputs Dead Zone).

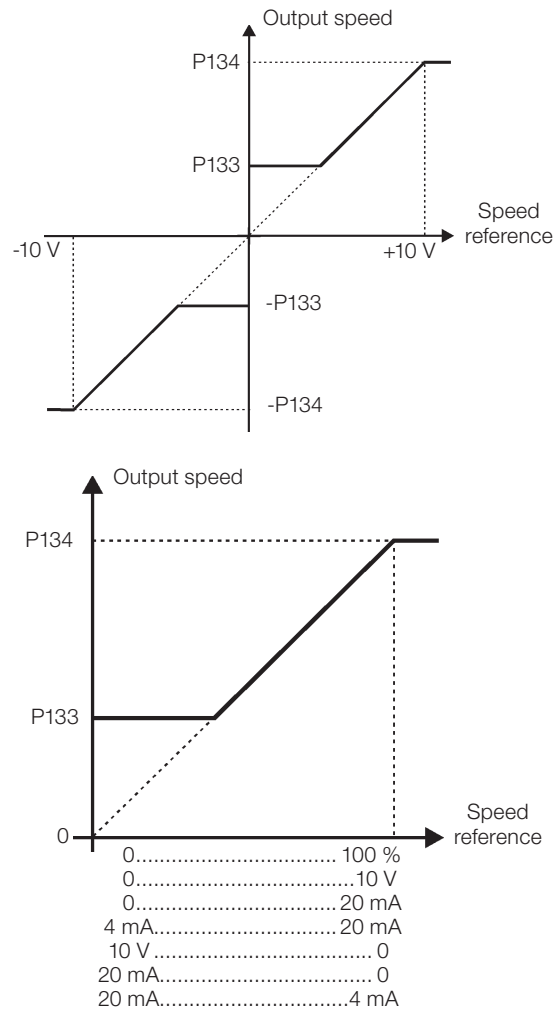

Figure 11.4: Speed limits considering an active dead zone (P233 = 1)

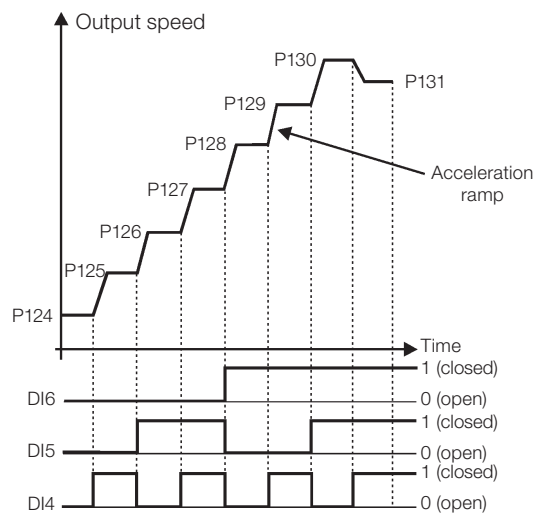

Figure 11.5: Multispeed

Parameter	Range [Factory Setting] Unit	Description/Notes
P136 Manual Torque Boost (IxR)	0 to 100 [0] 1	<ul style="list-style-type: none"> It compensates the voltage drop across the motor stator resistance at low speeds, by increasing the inverter output voltage, in order to maintain a constant motor torque in V/F operation. The optimum setting is the lowest P136 value that allows a satisfactory motor starting. Values higher than the necessary increase the motor current at low speeds, being able to cause overcurrent conditions (F070, F071 or F072). The maximum voltage increase occurs at 0 Hz and is equal to 20 % of the rated voltage, at null frequency, when P136 = 100. The setting 0 means inactive function.

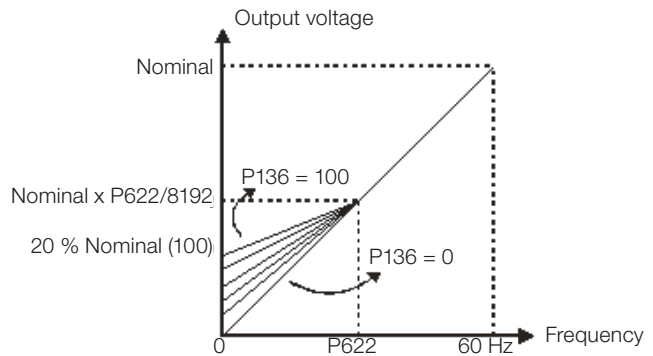

Figure 11.6: P202 = 0, V/F 60 Hz curve

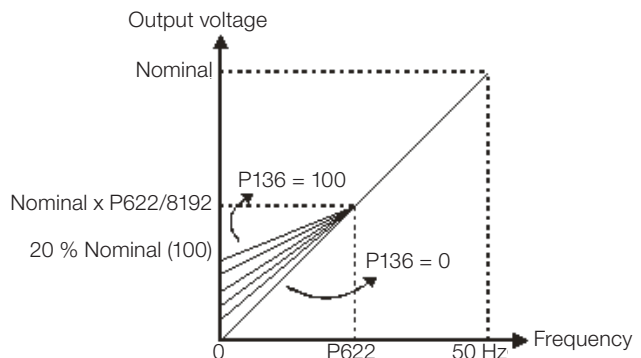

Figure 11.7: P202 = 1, V/F 50 Hz curve

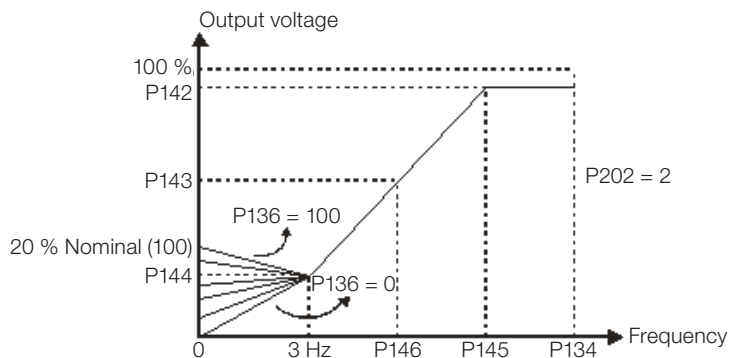

Figure 11.8: P202 = 2, adjustable V/f curve

Parameter	Range [Factory Setting] Unit	Description/Notes
-----------	------------------------------------	-------------------

P137
Automatic Torque Boost
(Automatic IxR)

0.000 to 1.000
[0.000]
0.001

- The Automatic Torque Boost compensates the voltage drop across the motor stator resistance as a function of the motor active current.
- The criteria for adjusting P137 are the same as for adjusting P136.

✓ This parameter is only visible on the display when P202 = 0, 1 or 2 (V/F Control)

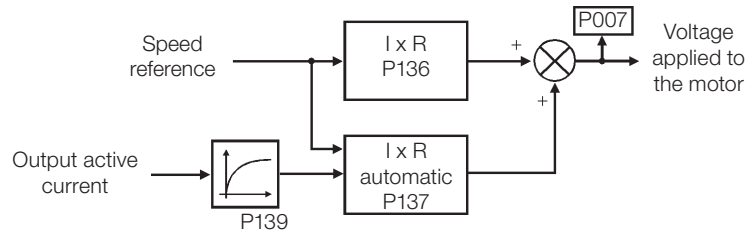

Figure 11.9: P137 block diagram

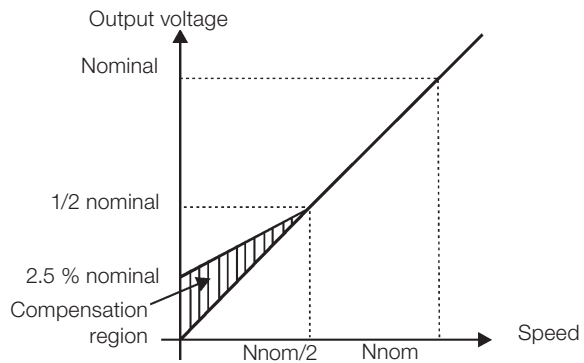

Figure 11.10: V/F curve with automatic torque boost

Parameter	Range [Factory Setting] Unit	Description/Notes
P138 ⁽²⁾ Rated Slip	-10.00 to +10.00 [0.00] 0.01 %	<p>Scalar mode:</p> <ul style="list-style-type: none"> ■ The parameter P138 (for values between -10.00 % and +10.00 %) is used to adjust the motor Slip Compensation function. It compensates the speed drop due to load application, by increasing the output frequency as a function of the motor active current increase. ■ P138 allows the user to accurately adjust the MVW-01 slip compensation. Once P138 is set, the inverter keeps a constant speed even with load variations, through the automatic adjustment of output voltage and frequency.

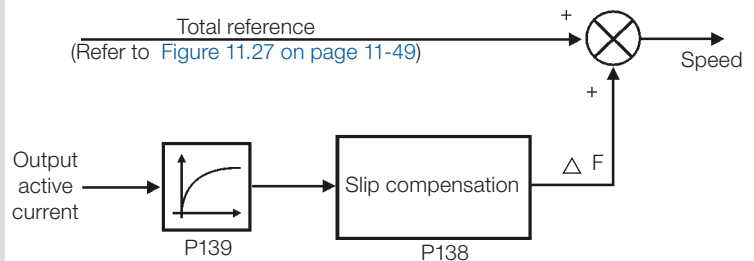

Figure 11.11: P138 block diagram (V/F)

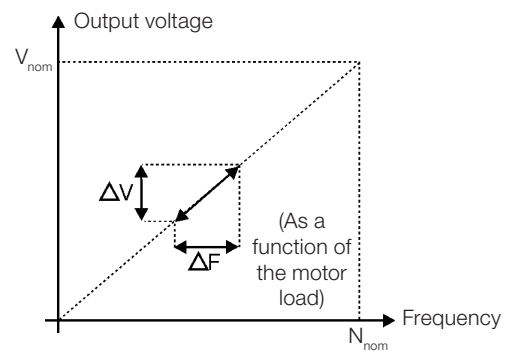

Figure 11.12: V/F curve with slip compensation

- P138 adjustment procedure:
Add motor with no load, at approximately half the utilization speed range.
Measure the speed of the motor or equipment. Apply rated load to the equipment.
Increment parameter P138 until the speed reaches the value with no load.
- Values P138 < 0.0 are used in special applications where you wish to reduce the output speed due to the increase of the motor current. E.g.: load distribution in motors driven in parallel.

Parameter	Range [Factory Setting] Unit	Description/Notes
		<ul style="list-style-type: none"> ■ Vector Mode (Droop Control): <div data-bbox="683 376 1369 607" style="text-align: center;"> </div> <p style="text-align: center;"><i>Figure 11.13: P138 block diagram (vector)</i></p> <ul style="list-style-type: none"> ■ In vector mode (with encoder or sensorless), the parameter P138 has the function described in the Figure 11.13 on page 11-24. ■ A value proportional to the motor load is added to the total reference speed. ■ This parameter is used in multimotor applications.
<p>P139 Output Current Filter (V/F Control)</p> <p> This parameter is only visible on the display when P202 = 0, 1 or 2 (V/F Control)</p>	<p>0.0 to 16.0 [0.2] 0.1 s</p>	<ul style="list-style-type: none"> ■ It adjusts the active current filter time constant. ■ It adjusts the response time of the slip compensation and the automatic torque boost. Refer to Figure 11.9 on page 11-22 and Figure 11.11 on page 11-23.

Parameter	Range [Factory Setting] Unit	Description/Notes												
<p>P140 Redundant Ventilation Selection</p>	<p>0 to 4 [0] -</p>	<ul style="list-style-type: none"> ■ It selects the active ventilation set and the redundant ventilation operation mode. <p style="text-align: center;"><i>Table 11.9: Redundant ventilation selection</i></p> <table border="1" data-bbox="850 454 1339 636"> <thead> <tr> <th>Function</th> <th>Description</th> </tr> </thead> <tbody> <tr> <td>0</td> <td>Inactive</td> </tr> <tr> <td>1</td> <td>Set A</td> </tr> <tr> <td>2</td> <td>Set B</td> </tr> <tr> <td>3</td> <td>Alternating A</td> </tr> <tr> <td>4</td> <td>Alternating B</td> </tr> </tbody> </table> <ul style="list-style-type: none"> ■ With P140 = Inactive, the redundant ventilation function is deactivated and all the software internal records and timers are reset. ■ With P140 programmed for Set A or Set B, the redundant ventilation function operates with just one set of fans, and the periodical set alternation must be done manually, by changing P140 between 1 and 2. In this operating mode, an automatic test of the second set is carried out after the time set in P141 has elapsed. ■ With P140 programmed for Alternating A or Alternating B, the redundant ventilation function initiates the operation of the selected set and starts alternating automatically between the two sets, according to the time programmed in P141. ■ The redundant ventilation status can be visualized in P041. ■ In order that the redundant ventilation function operates properly, it is necessary to program a digital output (DO1 to DO2, or RL1 to RL5) for the selection of the active set, and two digital inputs (DI1 to DI10) for set A and set B operation failure. ■ A ventilation failure alarm is activated when one of the sets fails (A093/A094 or A113/A114 alarm for set A or set B, respectively). ■ The Redundant Ventilation function is only possible with the appropriated hardware installed (refer to the supplier specific project). 	Function	Description	0	Inactive	1	Set A	2	Set B	3	Alternating A	4	Alternating B
Function	Description													
0	Inactive													
1	Set A													
2	Set B													
3	Alternating A													
4	Alternating B													
<p>P141 Number of Hours for Alternating Ventilation Sets</p>	<p>1 to 9999 [720] 1 h</p>	<ul style="list-style-type: none"> ■ It defines the number of hours between ventilation sets alternation. 												

Parameter	Range [Factory Setting] Unit	Description/Notes
P142 ⁽¹⁾ Maximum Output Voltage	0.0 to 100.0 [100.0] 0.1 %	<ul style="list-style-type: none"> ■ These parameters allow changing the standard V/F curves defined at P202. They can be used to create approximately quadratic curves, or with motors with nominal voltages and/or frequencies different from the standard ones. ■ This function allows changing the predefined standard curves, which represent the relationship between the output voltage and the output frequency of the drive, and consequently, the motor magnetization flux. This feature may be useful with special applications that require rated voltage or frequency values different from the standard ones. ■ The function is activated by setting P202 = 2 (Adjustable V/F). ■ P144 factory default value of (8.0 %) is defined for standard 60 Hz motors. If the rated motor frequency (set at P403) is different from 60 Hz, the factory default value of P144 may be inappropriate and cause difficulties during the motor start. <p>If it becomes necessary to increase the starting torque, increase the value of P144 gradually.</p> <ul style="list-style-type: none"> ■ Adjustable V/F parameter setting procedure: <ol style="list-style-type: none"> 1. Disable the inverter. 2. Verify the inverter data (P295 and P296). 3. Set the motor data (P400 to P406). 4. Adjust the parameters for P001 and P002 indication (P208, P210, P207, P216 and P217). 5. Set the speed limits (P133 and P134). 6. Set the Adjustable V/F function parameters (P142 to P146). 7. Enable the Adjustable V/F function (P202 = 2).
P143 ⁽¹⁾ Intermediate Output Voltage	0.0 to 100.0 [50.0] 0.1 %	
P144 ⁽¹⁾ Output Voltage at 3 Hz	0.0 to 100.0 [8.0] 0.1 %	
P145 ⁽¹⁾⁽²⁾ Field Weakening Speed	P133(>90) to P134 [1800] 1 rpm	
P146 ⁽¹⁾⁽²⁾ Intermediate Speed	90 to P145 [900] 1 rpm	
These parameters are only visible on the display(s) when P202 = 0, 1 or 2 (V/F Control)		

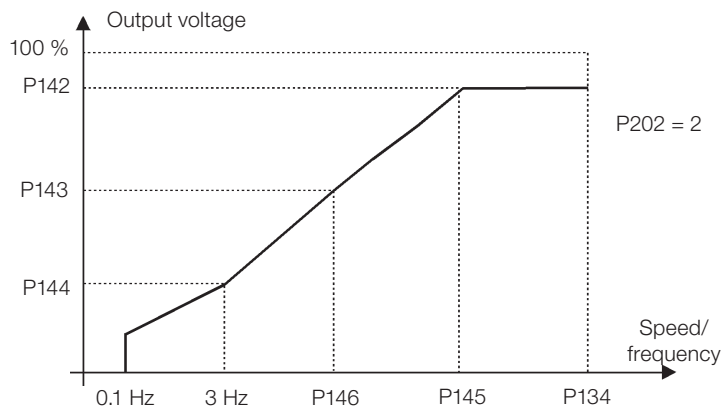



Figure 11.14: Adjustable V/F curve

Parameter	Range [Factory Setting] Unit	Description/Notes								
<p>P150 ⁽¹⁾ DC Link Voltage Regulation Mode</p> <p> This parameter is only visible in the display(s) when P202 = 3 or 4 (Vector Control)</p>	<p>0 to 2 [2] -</p>	<p><i>Table 11.10: DC Link voltage regulation mode</i></p> <table border="1"> <thead> <tr> <th data-bbox="726 358 877 392">P150</th> <th data-bbox="877 358 1468 392">Action</th> </tr> </thead> <tbody> <tr> <td data-bbox="726 392 877 481">0 = without losses (Normal)</td> <td data-bbox="877 392 1468 481">Deceleration ramp control equal to the scalar mode. Setting in P151.</td> </tr> <tr> <td data-bbox="726 481 877 616">1 = without losses (Automatic)</td> <td data-bbox="877 481 1468 616">Automatic deceleration ramp control. The Optimal Braking is inactive. The deceleration ram is automatically set to keep the DC link below the level set in P151. This procedure avoids F022 – overvoltage on the DC link. I can also be used with eccentric loads.</td> </tr> <tr> <td data-bbox="726 616 877 728">2 = with losses (Optimal Braking)</td> <td data-bbox="877 616 1468 728">The Optimal Braking is active as described in P151 for vector control. That gives the smallest deceleration time possible without using dynamic or regenerative braking. Maximum rotor flux set in in P179.</td> </tr> </tbody> </table>	P150	Action	0 = without losses (Normal)	Deceleration ramp control equal to the scalar mode. Setting in P151.	1 = without losses (Automatic)	Automatic deceleration ramp control. The Optimal Braking is inactive. The deceleration ram is automatically set to keep the DC link below the level set in P151. This procedure avoids F022 – overvoltage on the DC link. I can also be used with eccentric loads.	2 = with losses (Optimal Braking)	The Optimal Braking is active as described in P151 for vector control. That gives the smallest deceleration time possible without using dynamic or regenerative braking. Maximum rotor flux set in in P179.
P150	Action									
0 = without losses (Normal)	Deceleration ramp control equal to the scalar mode. Setting in P151.									
1 = without losses (Automatic)	Automatic deceleration ramp control. The Optimal Braking is inactive. The deceleration ram is automatically set to keep the DC link below the level set in P151. This procedure avoids F022 – overvoltage on the DC link. I can also be used with eccentric loads.									
2 = with losses (Optimal Braking)	The Optimal Braking is active as described in P151 for vector control. That gives the smallest deceleration time possible without using dynamic or regenerative braking. Maximum rotor flux set in in P179.									

Parameter	Range [Factory Setting] Unit	Description/Notes																								
P151 ⁽⁴⁾ DC Link Voltage Regulation Level	325 to 400 (P296 = 0) [375] 1 V	<p>Scalar Mode (P202 = 0, 1 or 2):</p> <ul style="list-style-type: none"> P151 adjust the DC link regulation level, in order to prevent F022 – DC link Overvoltage trips. This parameter, together with P152, allows two types of DC link regulation operation. See next the description and settings for both. <p>Ramp Holding – When P152 = 0.00 and P151 is different from the maximum value: Ramp holding – When the voltage of the DC link reaches the regulation level during deceleration, the deceleration ramp time is extended and the speed is maintained at a constant value until the DC link voltage leaves the actuation level. See Figure 11.15 on page 11-28.</p> <ul style="list-style-type: none"> This voltage regulation of the DC link (ramp holding) tries to avoid the locking of the inverter due to errors related to overvoltage on the DC link (F022) when the deceleration occurs with high-inertia loads or with short deceleration times. <div data-bbox="691 817 1339 1245" data-label="Figure"> </div>																								
	564 to 800 (P296 = 1) [618] 1 V																									
	3541 to 4064 (P296 = 2) [3571] 1 V																									
	5080 to 5831 (P296 = 3) [5123] 1 V																									
	6404 to 7350 (P296 = 4) [6428] 1 V																									
	5000 to 6500 (P296 = 5) [5800] 1 V																									
	7081 to 8127 (P296 = 6) [7107] 1 V																									
		<p>Ramp Holding – When P152 > 0.00 and P151 is different from the maximum value: When the DC link voltage reaches the regulation level (P151), the deceleration ramp is extended and the speed kept constant until the DC voltage becomes lower than the regulation level. Refer to the Figure 11.16 on page 11-29 and Figure 11.17 on page 11-29.</p>																								
		<p>Table 11.11: Recommended DC link voltage regulation levels</p> <table border="1"> <thead> <tr> <th>Inverter V_{nom}</th> <th>220 V / 230 V *</th> <th>380 V *</th> <th>2300 V</th> <th>3300 V</th> <th>4160 V</th> <th>6900 V</th> <th>4600 V</th> </tr> </thead> <tbody> <tr> <td>P296</td> <td>0</td> <td>1</td> <td>2</td> <td>3</td> <td>4</td> <td>5</td> <td>6</td> </tr> <tr> <td>P151</td> <td>375</td> <td>618</td> <td>3571</td> <td>5123</td> <td>6428</td> <td>6000</td> <td>7107</td> </tr> </tbody> </table> <p>Note: * Use of WEG</p>	Inverter V _{nom}	220 V / 230 V *	380 V *	2300 V	3300 V	4160 V	6900 V	4600 V	P296	0	1	2	3	4	5	6	P151	375	618	3571	5123	6428	6000	7107
Inverter V _{nom}	220 V / 230 V *	380 V *	2300 V	3300 V	4160 V	6900 V	4600 V																			
P296	0	1	2	3	4	5	6																			
P151	375	618	3571	5123	6428	6000	7107																			

Parameter	Range [Factory Setting] Unit	Description/Notes
		<ul style="list-style-type: none"> For inverters of rated voltage of 6000 V, 6300 V and 6600 V it must be parameterized P296 = 5; however, for those values of rated voltage, P151 must be manually set to: 6000 V - 5045 V 6300 V - 5300 V 6600 V - 5550 V

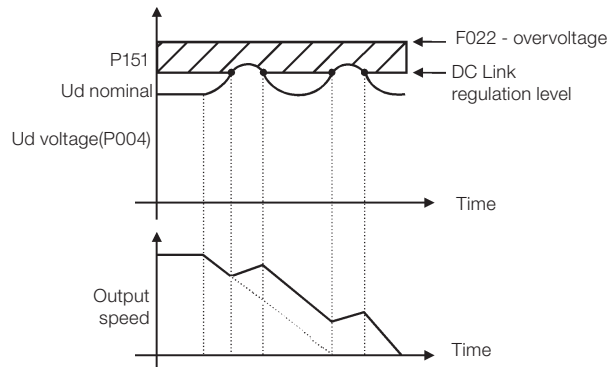

Figure 11.16: Deceleration with DC link voltage regulation



NOTE!

- In case locking for overvoltage (F022) still occurs during deceleration, the valued of parameter P152 must be gradually increased or the deceleration ramp time must be increased (P101 and/or P103). In case the line is permanently with overvoltage ($U_d > P151$), the inverter may not decelerate. Reduce the line voltage or increment P151.

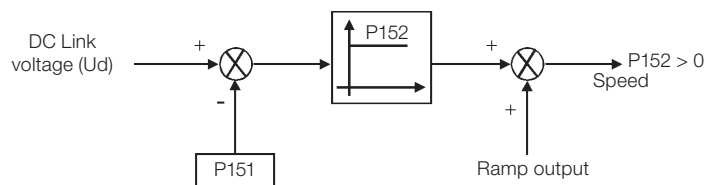

Figure 11.17: DC link voltage regulation block diagram

Vector mode (P202 = 3 or 4):

- P151 defines the DC link regulation level during braking. During the braking process, the deceleration ramp time is automatically extended, thus avoiding overvoltage fault F022.
- The DC link voltage regulation operation can be set in two forms:
 - With losses (Optimal Braking) - Set P150 = 2. In this mode the rotor flux current is applied in a manner that increases the losses in the motor, thus increasing the braking torque.
 - Without losses - Set P150 = 1. It only activates the DC link voltage regulation.

Parameter	Range [Factory Setting] Unit	Description/Notes																												
P152 Proportional Gain of the DC link Voltage Regulator [only for P202 = 0, 1 or 2 (V/F Control)]	0.00 to 9.99 [0.00] 0.01	<ul style="list-style-type: none"> Refer to P151 (with V/F control) and the Figure 11.16 on page 11-29. If P152 = 0.00 and P151 is different from the maximum value, then the Ramp Holding function will be active. Refer to P151 in V/F mode. P152 multiplies the voltage error of the DC link, that is, error = present DC link - P151. P152 is typically used to prevent overvoltage in applications with eccentric loads. 																												
P153⁽⁴⁾ Dynamic Braking Voltage Level	325 to 400 (P296 = 0) [375] 1 V 564 to 800 (P296 = 1) [618] 1 V 3541 to 4064 (P296 = 2) [3571] 1 V 5080 to 5831 (P296 = 3) [5123] 1 V 6404 to 7350 (P296 = 4) [6428] 1 V 7081 to 8127 (P296 = 6) [7107] 1 V	<ul style="list-style-type: none"> Dynamic braking can be used only if a braking resistor is connected to the MVW-01. The braking transistor operation voltage level must be set according to the supply line voltage. If P153 is adjusted at a level too close to the overvoltage (F022) trip level, then the fault may occur before the braking transistor and resistor are able to dissipate the regenerated energy. See Table 11.12 on page 11-30 and the Figure 11.18 on page 11-30. <p style="text-align: center;"><i>Table 11.12: Recommended adjustment</i></p> <table border="1" style="margin-left: auto; margin-right: auto;"> <thead> <tr> <th>Inverter V_{nom}</th> <th>P296</th> <th>P153</th> <th>F022</th> </tr> </thead> <tbody> <tr> <td>220 V / 230 V *</td> <td>0</td> <td>375 V</td> <td>> 420 V</td> </tr> <tr> <td>380 V *</td> <td>1</td> <td>618 V</td> <td>> 734 V</td> </tr> <tr> <td>2300 V</td> <td>2</td> <td>3571 V</td> <td>> 4064 V</td> </tr> <tr> <td>3300 V</td> <td>3</td> <td>5123 V</td> <td>> 5830 V</td> </tr> <tr> <td>4160 V</td> <td>4</td> <td>6428 V</td> <td>> 7350 V</td> </tr> <tr> <td>4600 V</td> <td>6</td> <td>7107 V</td> <td>> 8200 V</td> </tr> </tbody> </table> <p>* Use of WEG.</p> <ul style="list-style-type: none"> The MVW01-5L line does not offer the dynamic braking option. 	Inverter V _{nom}	P296	P153	F022	220 V / 230 V *	0	375 V	> 420 V	380 V *	1	618 V	> 734 V	2300 V	2	3571 V	> 4064 V	3300 V	3	5123 V	> 5830 V	4160 V	4	6428 V	> 7350 V	4600 V	6	7107 V	> 8200 V
Inverter V _{nom}	P296	P153	F022																											
220 V / 230 V *	0	375 V	> 420 V																											
380 V *	1	618 V	> 734 V																											
2300 V	2	3571 V	> 4064 V																											
3300 V	3	5123 V	> 5830 V																											
4160 V	4	6428 V	> 7350 V																											
4600 V	6	7107 V	> 8200 V																											
P154 Dynamic Braking Resistor	0.0 to 500.0 [0.0] 0.1 Ω (<100) - 1 Ω (≥100)	<ul style="list-style-type: none"> Set with value equal to the ohmic resistance of the braking resistor used. P154 = 0 disables the braking resistor overload protection. It must be programmed with 0 when no braking resistor is used. 																												

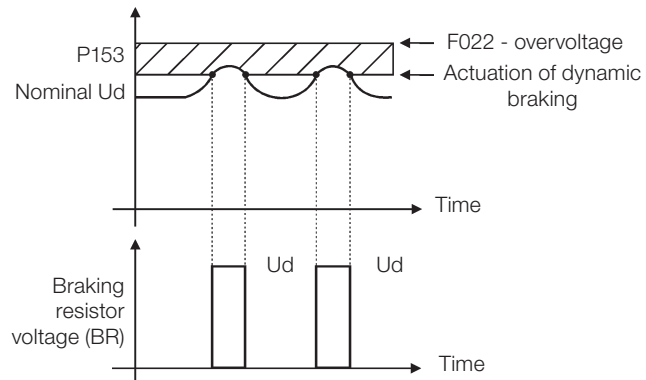

Figure 11.18: Dynamic Braking operation curve

- To actuate the dynamic braking:
 Install the dynamic braking resistor. Refer to the [Chapter 10 OPTIONAL ACCESSORIES AND BOARDS on page 10-1](#).
 Adjust P154 and P155 values according to the used braking resistor.

Parameter	Range [Factory Setting] Unit	Description/Notes
P155 Permitted Power on the Braking Resistor	10 to 1500 [50] 1 kW	<ul style="list-style-type: none"> It adjusts the overload protection for the dynamic braking resistor. Set according to the rated power of the braking resistor used. Operation: if the average power on the braking resistor is higher than the value set at P155 during 2 minutes, the inverter trips with F077 (Braking Resistor Overload) fault. Refer to the dynamic braking in the specific project.
P156 ⁽²⁾⁽⁵⁾ Motor Overload Current at 100 % of Nominal Speed	P157xP295 to 1.2xP295 [1.1xP401] 0.1 A (<100) - 1 A (>99.9)	<p>Figure 11.19: $I \times t$ function - overload detection</p>
P157 ⁽²⁾⁽⁵⁾ Motor Overload Current at 50 % of Nominal Speed	P158 to P156 [0.9xP401] 0.1 A (<100) - 1 A (>99.9)	
P158 ⁽²⁾⁽⁵⁾ Motor Overload Current at 5 % of Nominal Speed	0.2xP295 to P157 [0.5xP401] 0.1 A (<100) - 1 A (>99.9)	
		<p>Figure 11.20: Overload protection levels</p>
		<ul style="list-style-type: none"> It is for the motor and inverter overload protection ($I \times t$ - F072 - Motor Overload). The motor overload current is the value above which the inverter considers that the motor is operating under overload. The higher the difference between the motor current and the overload level, the sooner F072 occurs. P156 (Motor Overload Current at 100 % of Nominal Speed) must be adjusted 10 % higher than the used motor nominal current (P401).

Parameter	Range [Factory Setting] Unit	Description/Notes
		<ul style="list-style-type: none"> The overload current is obtained as a function of the speed being applied to the motor, according to the overload curve. Parameters P156, P157 and P158 are the three points used to form the motor overload curve, as shown in Figure 11.20 on page 11-31 for the factory setting. This curve is changed when P406 (ventilation type) is changed during the self-guided subroutine. Refer to Item 8.3.2 Initial Power-up (Parameter Settings) on page 8-18. With the overload current curve adjustment it is possible to program an overload value that varies according to the inverter operation speed (factory default), improving the protection for self-ventilated motors, or to use a constant overload level for any speed applied to the motor (motor with separated ventilation). <div style="border: 1px solid black; padding: 5px; margin-top: 10px;"> <p> NOTE! When P295 or P401 are changed, the values of P156 to P158 will be changed according to the new current: P156 = 1.10 x (P295 or P401) P157 = 0.90 x (P295 or P401) P158 = 0.50 x (P295 or P401)</p> </div>
P159 Temperature Alarm l x t	0 to 100 [80] 1 %	<ul style="list-style-type: none"> When the value visible in P076 reaches the value given in this parameter, the alarm A046 is indicated on the HMI.
P161 Speed Regulator Proportional Gain	0.0 to 200.0 [20.0] -	<ul style="list-style-type: none"> These gains are adjusted as a function of parameter P413 (Tm Constant). These gains can also be manually adjusted to optimize the speed dynamic response. Increase those gains in order to obtain a faster response. If the speed starts oscillating, reduce the gains.
P162 Integration Constant of the Speed Regulator	1 to 9999 [100] -	
P163 Local Reference Offset	-999 to +999 [0] 1	<ul style="list-style-type: none"> When the speed reference comes through the analog inputs AI1 to AI4, P163 or P164 can be used to compensate undesired offsets in these signals.
P164 Remote Reference Offset	-999 to +999 [0] 1	
P165 Speed Filter	0.001 to 1.000 [0.012] 0.001 s	<ul style="list-style-type: none"> It adjusts the time constant for the speed filter.

Parameter	Range [Factory Setting] Unit	Description/Notes
<p>P167 Current Regulator Proportional Gain</p> <p>P168 Current Regulator Integral Gain</p>	<p>0.000 to 9.999 [0.080] 0.001</p> <p>0.1 to 999.9 [12.3] 0.1</p>	<ul style="list-style-type: none"> P167 and P168 are adjusted as a function of parameters P411 and P409, respectively.
<p>P169 With V/F Control (P202 = 0, 1 or 2): Maximum Output Current</p>	<p>P295 ≤ 69 (G1) 0.2xP295 to 1.5xP295 [1.35xP295] 0.1 A(<100) - 1 A(>99.9)</p> <p>P295 > 69 (G2) 0.1xP295 to 1.5xP295 (HD) [1.0xP295 (MX)]</p>	<ul style="list-style-type: none"> It is intended to avoid the motor stalling (locking) during overloads. If the load on the motor increases, its current will increase. If the current exceeds the value set in P169, the motor speed will be reduced following the deceleration ramp until the current is below the value set in P169. When the overload disappears, the speed goes back to the normal value.
<p style="text-align: center;">Figure 11.21: Curves showing the current limitation actuation</p>		
<p> NOTE! The default value P169 is current in overload mode MX.</p>		
<p>P170 Maximum Reverse Torque Current</p> <p>P171 With Vector Control (P202 = 3 or 4): Maximum Current of Forward Torque</p>	<p>0 to P295/P401x150 [105] 1 %</p> <p>0 to P295/P401x150 [105] 1 %</p>	<ul style="list-style-type: none"> It limits the value of the motor current component that produce torque. The adjustment is expressed in percentage (%) of the inverter rated current (P295 value). During the current limitation process, the motor current can be calculated by: $I_{\text{motor}} = [(P170 \text{ or } P171)^2 + (P410)^2]^{1/2}$ During the optimal braking, P171 acts as the limitation of the maximum output current to generate the forward braking torque (refer to P151). Although the value of P170 and P171 depends on the relation between P295 and P401, its value is limited to 250 %.

Parameter	Range [Factory Setting] Unit	Description/Notes						
P175 ⁽¹⁾ Flux Regulator Proportional Gain	0.0 to 999.9 [50.0] 0.1	<ul style="list-style-type: none"> These gains are adjusted as a function of the parameter P412. 						
P176 ⁽³⁾ Integration Constant of the Flux Regulator	1 to 9999 [900] -							
P177 Minimum Flux	0 to 120 [0] 1 %	<ul style="list-style-type: none"> Motor flux conditions. 						
P178 Nominal Flux	0 to 120 [100] 1 %							
P179 Maximum Flux	0 to 200 [120] 1 %							
P180 Starting Point of the Field Weakening	0 to 120 [85] 1 %	<ul style="list-style-type: none"> It expresses the % of the modulation index from which the motor field weakening occurs. 						
This parameter is only visible with P202 > 2.								
P181 Magnetization Mode	0 or 1 [0] -	<p style="text-align: center;"><i>Table 11.13: Magnetization mode</i></p> <table border="1"> <thead> <tr> <th>P181</th> <th>Action</th> </tr> </thead> <tbody> <tr> <td>0 = General Enable</td> <td>It applies magnetization current after General Enable ON</td> </tr> <tr> <td>1 = Start/Stop</td> <td>It applies magnetization current after Start/Stop ON</td> </tr> </tbody> </table>	P181	Action	0 = General Enable	It applies magnetization current after General Enable ON	1 = Start/Stop	It applies magnetization current after Start/Stop ON
P181	Action							
0 = General Enable	It applies magnetization current after General Enable ON							
1 = Start/Stop	It applies magnetization current after Start/Stop ON							

Parameter	Range [Factory Setting] Unit	Description/Notes
P182 Flux Reference Regulator Proportional Gain This parameter is only visible with P202 > 2.	0.00 to 99.99 [0.20] 0.1	<ul style="list-style-type: none"> PI gains of the flux regulator.
P183 Flux Reference Regulator Integral Gain This parameter is only visible with P202 > 2.	1 to 9999 [25] -	

11.3 CONFIGURATION PARAMETERS - P200 TO P399

Parameter	Range [Factory Setting] Unit	Description/Notes										
P200 Password	0 or 1 [1] -	<p><i>Table 11.14: Password status</i></p> <table border="1"> <thead> <tr> <th>P200</th> <th>Result</th> </tr> </thead> <tbody> <tr> <td>0 (Inactive)</td> <td>Disables the password and allows changing parameters content regardless of P000 setting.</td> </tr> <tr> <td>1 (Active)</td> <td>Enables the password that allows changing parameter contents only when P000 is equal to that password.</td> </tr> </tbody> </table> <ul style="list-style-type: none"> The factory default value for the password is P000 = 5. Refer to P000 in order to change the password. 	P200	Result	0 (Inactive)	Disables the password and allows changing parameters content regardless of P000 setting.	1 (Active)	Enables the password that allows changing parameter contents only when P000 is equal to that password.				
P200	Result											
0 (Inactive)	Disables the password and allows changing parameters content regardless of P000 setting.											
1 (Active)	Enables the password that allows changing parameter contents only when P000 is equal to that password.											
P201 Language Selection	0 to 3 [To be defined by the user] -	<p><i>Table 11.15: Language selection</i></p> <table border="1"> <thead> <tr> <th>P201</th> <th>Language</th> </tr> </thead> <tbody> <tr> <td>0</td> <td>Portuguese</td> </tr> <tr> <td>1</td> <td>English</td> </tr> <tr> <td>2</td> <td>Español</td> </tr> <tr> <td>3</td> <td>Deutsch</td> </tr> </tbody> </table>	P201	Language	0	Portuguese	1	English	2	Español	3	Deutsch
P201	Language											
0	Portuguese											
1	English											
2	Español											
3	Deutsch											

Parameter	Range [Factory Setting] Unit	Description/Notes
-----------	------------------------------------	-------------------

P202 ⁽¹⁾⁽²⁾
Control Type

0 to 4
[0]
-

Table 11.16: Control type selection

P202	Control Type
0	V/F 60 Hz
1	V/F 50 Hz
2	Adjustable V/F (refer to P142 to P146)
3	Sensorless Vector
4	Vector with Encoder

Self-Guided Menu:

- When P202 is programmed for sensorless vector (P202 = 3) or vector with encoder (P202 = 4), the inverter enters the guided start-up routine (refer to the [Figure 11.22 on page 11-36](#)).
- In this mode, the user must adjust a series of motor parameters, so that the vector control operates properly.

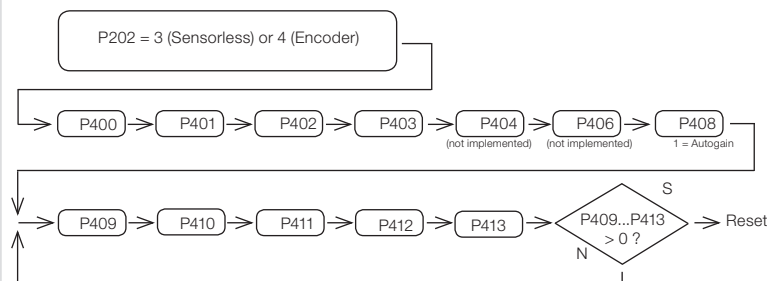

Figure 11.22: Guided start-up routine sequence

The table below shows the summarized description of each parameter:

Table 11.17: Guided start-up routine

Parameter	Description
P400	Motor rated voltage
P401	Motor rated current
P402	Motor rated speed
P403	Motor rated frequency
P404	Not implemented in this software version
P406	Not implemented in this software version
P408	Self-tuning 0 = Inactive 1 = Autogain (automatic calculation of the gains of the controllers)
P409	Motor stator resistance
P410	Motor magnetization current
P411	Leakage inductance
P412	Motor rotor time constant (Lr/Rr)
P413	Motor mechanical time constant (Tm)

- Refer to the specific description of each parameter for more details.
- Parameters from P409 to P413 correspond to motor internal parameters, and they must be programmed according to the motor nameplate data.
- The values programmed at P409 to P413 must be different from zero; otherwise, the inverter will not leave the guided start-up routine.
- The configuration of this parameter must be done under the orientation of WEG technical assistance.



Parameter	Range [Factory Setting] Unit	Description/Notes										
P203 ⁽¹⁾ Special Function Selection	0 to 3 [0] -	<ul style="list-style-type: none"> It defines the special function selection: <div style="text-align: center;"> <p><i>Table 11.18: Selection of the special functions</i></p> <table border="1"> <thead> <tr> <th>P203</th> <th>Functions</th> </tr> </thead> <tbody> <tr> <td>0</td> <td>None</td> </tr> <tr> <td>1</td> <td>PID Regulator</td> </tr> <tr> <td>2</td> <td>Trace</td> </tr> <tr> <td>3</td> <td>Trace + PID</td> </tr> </tbody> </table> </div> For the PID regulator special function, refer to the detailed description of the related parameters P520 to P535. When P203 is changed to 1 or 3, P265 is automatically changed to 15 - Manual/Automatic. 	P203	Functions	0	None	1	PID Regulator	2	Trace	3	Trace + PID
P203	Functions											
0	None											
1	PID Regulator											
2	Trace											
3	Trace + PID											
P204 ⁽¹⁾ Load/Save Parameters	0 to 11 [0] -	<ul style="list-style-type: none"> Parameters P295 (Rated Current), P296 (Rated Voltage), P297 (Switching Frequency), P308 (Serial Address) and P201 (Language selection) will not be changed when P204 = 5 (factory default). To load parameter of User 1 (P204 = 7) and/or User 2 (P204 = 8) to the operating area of the MVW-01, it is necessary that the User 1 Memory and/or User 2 Memory have been previously saved (P204 = 10 and/or P204 = 11). Options P204 = 5, 7, 8, 10 and 11 are disabled when P309 ≠ 0 (Fieldbus active). <div style="text-align: center;"> </div>										

Figure 11.23: Parameter transference

Parameter	Range [Factory Setting] Unit	Description/Notes																		
P206 Auto-Reset Time	0 to 255 [0] 1 s	<ul style="list-style-type: none"> ■ In the event of a fault trip the inverter can initiate an automatic reset after the time given by P206 has elapsed. ■ If $P206 \leq 2$, then auto-reset does not occur. ■ If after the auto-reset the same fault is repeated three times consecutively, then the Auto-Reset function will be disabled. A fault is considered consecutive if it happens again within 30 seconds after an auto-reset. Therefore, if an error occurs four consecutive times, it will be permanently indicated and the drive will be disabled (in such case a reset command becomes necessary. Eg.: HMI, DI, serial, etc). 																		
<i>Table 11.19: Load/save parameters</i>																				
<table border="1" style="width: 100%; border-collapse: collapse;"> <thead> <tr> <th data-bbox="687 371 836 394">P204</th> <th data-bbox="1059 371 1134 394">Action</th> </tr> </thead> <tbody> <tr> <td data-bbox="703 416 820 439">0, 1, 2, 6, 9</td> <td data-bbox="847 405 1011 450">Without function: No action.</td> </tr> <tr> <td data-bbox="751 472 772 495">3</td> <td data-bbox="847 461 1171 506">Reset P043: It resets the enabled time counter.</td> </tr> <tr> <td data-bbox="751 528 772 551">4</td> <td data-bbox="847 517 1091 562">Reset P044: It resets the MWh counter.</td> </tr> <tr> <td data-bbox="751 595 772 618">5</td> <td data-bbox="847 573 1283 651">Load WEG - 60 Hz: It reset all the parameters to the 60 Hz factory default values.</td> </tr> <tr> <td data-bbox="751 685 772 707">7</td> <td data-bbox="847 663 1315 741">Load User 1: It resets all the parameters to the values stored in the User Memory 1.</td> </tr> <tr> <td data-bbox="751 775 772 797">8</td> <td data-bbox="847 752 1315 831">Load User 2: It resets all the parameters to the values stored in the User Memory 2.</td> </tr> <tr> <td data-bbox="743 864 780 887">10</td> <td data-bbox="847 842 1299 920">Save User 1: It saves all the current inverter parameters in the User Memory 1.</td> </tr> <tr> <td data-bbox="743 954 780 976">11</td> <td data-bbox="847 931 1299 1010">Save User 2: It saves all the current inverter parameters in the User Memory 2.</td> </tr> </tbody> </table>			P204	Action	0, 1, 2, 6, 9	Without function: No action.	3	Reset P043: It resets the enabled time counter.	4	Reset P044: It resets the MWh counter.	5	Load WEG - 60 Hz: It reset all the parameters to the 60 Hz factory default values.	7	Load User 1: It resets all the parameters to the values stored in the User Memory 1.	8	Load User 2: It resets all the parameters to the values stored in the User Memory 2.	10	Save User 1: It saves all the current inverter parameters in the User Memory 1.	11	Save User 2: It saves all the current inverter parameters in the User Memory 2.
P204	Action																			
0, 1, 2, 6, 9	Without function: No action.																			
3	Reset P043: It resets the enabled time counter.																			
4	Reset P044: It resets the MWh counter.																			
5	Load WEG - 60 Hz: It reset all the parameters to the 60 Hz factory default values.																			
7	Load User 1: It resets all the parameters to the values stored in the User Memory 1.																			
8	Load User 2: It resets all the parameters to the values stored in the User Memory 2.																			
10	Save User 1: It saves all the current inverter parameters in the User Memory 1.																			
11	Save User 2: It saves all the current inverter parameters in the User Memory 2.																			
<div style="display: flex; align-items: flex-start;"> <div style="margin-right: 10px;"> </div> <div> <p>NOTE! The action of loading/saving parameters will occur only after P204 has been set and the key has been pressed.</p> </div> </div>																				

Parameter	Range [Factory Setting] Unit	Description/Notes																					
P208 ⁽²⁾ Reference Scale Factor	1 to 18000 [1800] 1	<ul style="list-style-type: none"> It defines how the Speed Reference (P001) and the Motor Speed (P002) will be presented when the motor is running at synchronous speed. To indicate the values in rpm: Adjust P208 for the synchronous speed, according to the table below. <p style="text-align: center;"><i>Table 11.20: Synchronous speed reference in rpm</i></p> <table border="1" style="margin-left: auto; margin-right: auto;"> <thead> <tr> <th>Frequency</th> <th>Number of Motor Poles</th> <th>Synchronous Speed</th> </tr> </thead> <tbody> <tr> <td rowspan="4">50 Hz</td> <td>2</td> <td>3000</td> </tr> <tr> <td>4</td> <td>1500</td> </tr> <tr> <td>6</td> <td>1000</td> </tr> <tr> <td>8</td> <td>750</td> </tr> <tr> <td rowspan="4">60 Hz</td> <td>2</td> <td>3600</td> </tr> <tr> <td>4</td> <td>1800</td> </tr> <tr> <td>6</td> <td>1200</td> </tr> <tr> <td>8</td> <td>900</td> </tr> </tbody> </table> <ul style="list-style-type: none"> In order to indicate other units: <p>The value shown can be calculated using the formulas: $P002 = \text{speed} \times P208 / \text{synchronous speed} \times (10)^{P210}$ $P001 = \text{reference} \times P208 / \text{synchronous speed} \times (10)^{P210}$</p> <p>where: Speed = actual speed in rpm. Synchronous Speed = $120 \times P403 / \text{poles}$. Poles = $120 \times P403 / P402$, can be equivalent to 2, 4, 6, 8 or 10. Reference = speed reference in rpm. The number of places after the decimal point is defined in P210.</p> <p>Example: If speed = synchronous speed = 1800, P207 = L/s, P208 = 900 (desired indication 90.0, therefore P210 = 1), thus the value shown will be: 90.0 L/s.</p>	Frequency	Number of Motor Poles	Synchronous Speed	50 Hz	2	3000	4	1500	6	1000	8	750	60 Hz	2	3600	4	1800	6	1200	8	900
Frequency	Number of Motor Poles	Synchronous Speed																					
50 Hz	2	3000																					
	4	1500																					
	6	1000																					
	8	750																					
60 Hz	2	3600																					
	4	1800																					
	6	1200																					
	8	900																					
P209 Motor Phase Loss Detection	0 or 1 [0] -	<p style="text-align: center;"><i>Table 11.21: Motor phase loss</i></p> <table border="1" style="margin-left: auto; margin-right: auto;"> <thead> <tr> <th>P209</th> <th>Function</th> </tr> </thead> <tbody> <tr> <td>0</td> <td>Inactive</td> </tr> <tr> <td>1</td> <td>Active</td> </tr> </tbody> </table> <ul style="list-style-type: none"> The Motor Phase Loss Detection trips indicating F076 (Motor Phase Loss) when the following conditions are simultaneously satisfied: <ol style="list-style-type: none"> P209 = active. Enabled inverter. Speed reference higher than 3 %. $I_{\text{max}} > 1.125 \times I_{\text{min}}$. Where: I_{max} is the highest current of the three phases. I_{min} is the lowest current of the three phases. 	P209	Function	0	Inactive	1	Active															
P209	Function																						
0	Inactive																						
1	Active																						

Parameter	Range [Factory Setting] Unit	Description/Notes						
P211 Disable by N = 0 (Stop Logic)	0 or 1 [1] -	<p><i>Table 11.22: Disable by N = 0</i></p> <table border="1"> <thead> <tr> <th>P211</th> <th>Function</th> </tr> </thead> <tbody> <tr> <td>0</td> <td>Inactive</td> </tr> <tr> <td>1</td> <td>Active</td> </tr> </tbody> </table> <ul style="list-style-type: none"> When active it disables the inverter (general disable) when the speed reference and the actual speed become lower than the value adjusted in P291 (Zero Speed Zone) and after the time adjusted in P213 has elapsed. The inverter is enabled again when any of the conditions defined in P212 is fulfilled. 	P211	Function	0	Inactive	1	Active
P211	Function							
0	Inactive							
1	Active							
P212 Condition for Disable Output by N = 0	0 or 1 [0] -	<p><i>Table 11.23: Condition for disable output</i></p> <table border="1"> <thead> <tr> <th>P212 (P211 = 1)</th> <th>Inverter Leaves the Disable Condition by N = 0</th> </tr> </thead> <tbody> <tr> <td>0</td> <td>P001 (N*) > P291 or P002 (N) > P291</td> </tr> <tr> <td>1</td> <td>P001 (N*) > 0</td> </tr> </tbody> </table> <ul style="list-style-type: none"> When the PID regulator is active (P203 = 1 or 3) and in automatic mode, besides the condition programmed in P212, it is also necessary that the PID error (the difference between the setpoint and the process variable) be more than the value programmed in P535, so that the inverter be able to leave the zero speed disable. 	P212 (P211 = 1)	Inverter Leaves the Disable Condition by N = 0	0	P001 (N*) > P291 or P002 (N) > P291	1	P001 (N*) > 0
P212 (P211 = 1)	Inverter Leaves the Disable Condition by N = 0							
0	P001 (N*) > P291 or P002 (N) > P291							
1	P001 (N*) > 0							
P213 Time Delay for Zero Speed Disable	0 to 999 [0] 1 s	<ul style="list-style-type: none"> P213 = 0: zero Speed Disable without timing. P213 > 0: zero Speed Disable with timing. Timing begins after the speed reference and the actual speed become lower than the speed set in P291. When the time programmed at P213 has elapsed the inverter will be disabled. If during that timing any of the conditions for the disable no longer exists, the timer is reset and normal operation continues. 						
P214 ^{(1) (6)} Line Phase Loss Detection	0 or 1 [1] -	<p><i>Table 11.24: Line phase loss detection</i></p> <table border="1"> <thead> <tr> <th>P214</th> <th>Function</th> </tr> </thead> <tbody> <tr> <td>0</td> <td>Inactive</td> </tr> <tr> <td>1</td> <td>Active</td> </tr> </tbody> </table> <ul style="list-style-type: none"> When P214 is active it controls the following faults and alarms: A001: line undervoltage alarm. A002: line overvoltage alarm. F003: line undervoltage. F004: line overvoltage. F006: unbalance / line phase loss. The phase loss detector is released to actuate when: <ol style="list-style-type: none"> P214 = active. Enabled inverter. Finished pre-charge. No active Ride-through function. 	P214	Function	0	Inactive	1	Active
P214	Function							
0	Inactive							
1	Active							

Parameter	Range [Factory Setting] Unit	Description/Notes								
P215 ⁽¹⁾ Keypad Copy Function	0 to 2 [0] -	<p style="text-align: center;"><i>Table 11.25: Copy function</i></p> <table border="1" data-bbox="759 367 1430 568"> <thead> <tr> <th>P215</th> <th>Action</th> </tr> </thead> <tbody> <tr> <td>0 = Inactive</td> <td>None.</td> </tr> <tr> <td>1 = INV → HMI</td> <td>It transfers the current parameter values to the nonvolatile EEPROM memory of the HMI. The current inverter parameters are not changed.</td> </tr> <tr> <td>2 = HMI → INV</td> <td>It transfers the contents of the HMI memory to the current inverter parameters.</td> </tr> </tbody> </table> <ul style="list-style-type: none"> ■ The copy function is used to transfer the parameter contents from one inverter to another. The inverters must be of the same type (voltage/current) and with the same software version installed. <p>Note: If parameters from an inverter with a software version different from software version of the inverter where they are supposed to be transferred have been previously copied into the keypad, then the operation will not be executed and the keypad will indicate F082 (Fault in the Copy function). A version is understood as different when the digits x and y, of a Vx.yz version, are different.</p> <p>Example: version V1.60 → (x = 1, y = 6 and z = 0) previously stored on the HMI.</p> <ol style="list-style-type: none"> I. Inverter Version: V1.75 → (x' = 1, y' = 7 and z' = 5). P215 = 2 → F082 [(y = 6) ≠ (y' = 7)]. II. Inverter Version: V1.62 → (x' = 1, y' = 6 and z' = 2). P215 = 2 → normal copy [(y = 6) = (y' = 6)]. <p>Procedure:</p> <ol style="list-style-type: none"> 1. Connect the HMI to the inverter on which you wish to copy the parameters (Inverter A). 2. Set P215 = 1 (INV → HMI) in order to transfer the parameters from the inverter A to the HMI. Press the  key. P215 resets to 0 (inactive) automatically after the parameter transferring has been completed. 3. Turn off the inverter HMI. <div style="border: 1px solid black; padding: 5px; margin: 10px 0;"> <p> NOTE! The calibration parameters (WEG use) are also copied.</p> </div> <ol style="list-style-type: none"> 4. Connect the keypad to the inverter B, to which the parameters have to be transferred. 5. Set P215 = 2 (HMI → INV) in order to transfer the parameters from the HMI to the inverter B. Press the  key. P215 resets to 0 (Inactive) automatically after the parameter transferring has been completed. From that moment on, the inverters A and B have the same parameters. 6. If the inverters A and B drive different motors, then verify the inverter B motor parameters. 	P215	Action	0 = Inactive	None.	1 = INV → HMI	It transfers the current parameter values to the nonvolatile EEPROM memory of the HMI. The current inverter parameters are not changed.	2 = HMI → INV	It transfers the contents of the HMI memory to the current inverter parameters.
P215	Action									
0 = Inactive	None.									
1 = INV → HMI	It transfers the current parameter values to the nonvolatile EEPROM memory of the HMI. The current inverter parameters are not changed.									
2 = HMI → INV	It transfers the contents of the HMI memory to the current inverter parameters.									

Parameter	Range [Factory Setting] Unit	Description/Notes
-----------	------------------------------------	-------------------

7. To copy the parameters from the inverter A to more inverters, repeat the steps from 4 to 6.

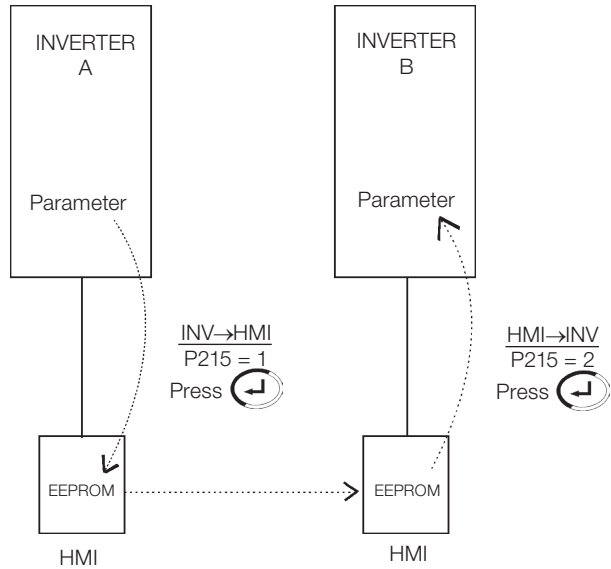









Figure 11.24: Copy of the parameters from inverter A to B

















It is not possible to operate the HMI while it is performing the Copy function.









Note: Inverters that received parameters from the other inverter must undergo the calibration process.

 **NOTE!** The transfer process from one inverter to another must be performed/oriented by WEG technical assistance.

Parameter	Range [Factory Setting] Unit	Description/Notes																												
P220 ⁽¹⁾ LOCAL/REMOTE Selection Source	0 to 12 [11] -	<ul style="list-style-type: none"> It defines the origin of the command that will select between the Local situation and the Remote situation. <p style="text-align: center;"><i>Table 11.26: Local/Remote selection</i></p> <table border="1" style="margin-left: auto; margin-right: auto;"> <thead> <tr> <th>P220</th> <th>Function</th> </tr> </thead> <tbody> <tr> <td>0</td> <td>Always Local.</td> </tr> <tr> <td>1</td> <td>Always Remote.</td> </tr> <tr> <td>2</td> <td>HMI  key (LOCAL default).</td> </tr> <tr> <td>3</td> <td>HMI  key (REMOTE default).</td> </tr> <tr> <td>4</td> <td>Digital Inputs DI2...DI10 (P264...P272).</td> </tr> <tr> <td>5</td> <td>Serial (Local Default).</td> </tr> <tr> <td>6</td> <td>Serial (Remote Default).</td> </tr> <tr> <td>7</td> <td>Fieldbus (Local Default).</td> </tr> <tr> <td>8</td> <td>Fieldbus (Remote Default).</td> </tr> <tr> <td>9</td> <td>Local PLC.</td> </tr> <tr> <td>10</td> <td>Remote PLC.</td> </tr> <tr> <td>11</td> <td>Graphic HMI (Local Default).</td> </tr> <tr> <td>12</td> <td>Graphic HMI (Remote Default).</td> </tr> </tbody> </table> <ul style="list-style-type: none"> With the factory default settings the  key selects between Local and Remote. After powering up the inverter, it will initiate in Local mode (Local default). 	P220	Function	0	Always Local.	1	Always Remote.	2	HMI  key (LOCAL default).	3	HMI  key (REMOTE default).	4	Digital Inputs DI2...DI10 (P264...P272).	5	Serial (Local Default).	6	Serial (Remote Default).	7	Fieldbus (Local Default).	8	Fieldbus (Remote Default).	9	Local PLC.	10	Remote PLC.	11	Graphic HMI (Local Default).	12	Graphic HMI (Remote Default).
P220	Function																													
0	Always Local.																													
1	Always Remote.																													
2	HMI  key (LOCAL default).																													
3	HMI  key (REMOTE default).																													
4	Digital Inputs DI2...DI10 (P264...P272).																													
5	Serial (Local Default).																													
6	Serial (Remote Default).																													
7	Fieldbus (Local Default).																													
8	Fieldbus (Remote Default).																													
9	Local PLC.																													
10	Remote PLC.																													
11	Graphic HMI (Local Default).																													
12	Graphic HMI (Remote Default).																													

Parameter	Range [Factory Setting] Unit	Description/Notes																														
P221 ⁽¹⁾ Speed Reference Selection – LOCAL Situation	0 to 13 [13] -	<ul style="list-style-type: none"> The Alx' designation refers to the analog signal obtained after the addition of the Alx input to the OFFSET and its multiplication by the applied gain (refer to the Figure 11.31 on page 11-52). <p style="text-align: center;"><i>Table 11.27: Local/Remote speed reference selection</i></p> <table border="1"> <thead> <tr> <th>P221/P222</th> <th>Function</th> </tr> </thead> <tbody> <tr> <td>0</td> <td>HMI and keys.</td> </tr> <tr> <td>1</td> <td>Analog Input AI1' (P234 to P236).</td> </tr> <tr> <td>2</td> <td>Analog Input AI2' (P237 to P240 and P248).</td> </tr> <tr> <td>3</td> <td>Analog Input AI3' (P241 to P244).</td> </tr> <tr> <td>4</td> <td>Analog Input AI4' (P245 to P247).</td> </tr> <tr> <td>5</td> <td>Sum of Analog Inputs (AI1' + AI2') > 0 (Negative values are zeroed).</td> </tr> <tr> <td>6</td> <td>Sum of Analog Inputs (AI1' + AI2').</td> </tr> <tr> <td>7</td> <td>Electronic Potentiometer (E.P.).</td> </tr> <tr> <td>8</td> <td>Multispeed (P124 to P131).</td> </tr> <tr> <td>9</td> <td>Serial.</td> </tr> <tr> <td>10</td> <td>Fieldbus.</td> </tr> <tr> <td>11</td> <td>Analog Input AI5' (P721 to P724).</td> </tr> <tr> <td>12</td> <td>PLC.</td> </tr> <tr> <td>13</td> <td>Graphic HMI.</td> </tr> </tbody> </table>	P221/P222	Function	0	HMI and keys.	1	Analog Input AI1' (P234 to P236).	2	Analog Input AI2' (P237 to P240 and P248).	3	Analog Input AI3' (P241 to P244).	4	Analog Input AI4' (P245 to P247).	5	Sum of Analog Inputs (AI1' + AI2') > 0 (Negative values are zeroed).	6	Sum of Analog Inputs (AI1' + AI2').	7	Electronic Potentiometer (E.P.).	8	Multispeed (P124 to P131).	9	Serial.	10	Fieldbus.	11	Analog Input AI5' (P721 to P724).	12	PLC.	13	Graphic HMI.
P221/P222	Function																															
0	HMI and keys.																															
1	Analog Input AI1' (P234 to P236).																															
2	Analog Input AI2' (P237 to P240 and P248).																															
3	Analog Input AI3' (P241 to P244).																															
4	Analog Input AI4' (P245 to P247).																															
5	Sum of Analog Inputs (AI1' + AI2') > 0 (Negative values are zeroed).																															
6	Sum of Analog Inputs (AI1' + AI2').																															
7	Electronic Potentiometer (E.P.).																															
8	Multispeed (P124 to P131).																															
9	Serial.																															
10	Fieldbus.																															
11	Analog Input AI5' (P721 to P724).																															
12	PLC.																															
13	Graphic HMI.																															
P222 ⁽¹⁾ Speed Reference Selection – REMOTE Situation	0 to 13 [0] -	<ul style="list-style-type: none"> The factory default for the Local speed reference is via HMI and keys, and for Remote speed reference is via Analog Input AI1. The reference value adjusted with the and keys is contained in the parameter P121. Check the operation of the Electronic Potentiometer in Figure 11.39 on page 11-66. When the option 7 (E.P.), set P265 or P267 to 5 and P266 or P268 to 5. When selecting option 8, set P266 and/or P267 and/or P268 to 7. 																														
P223 ⁽¹⁾ Forward/Reverse Selection – LOCAL Situation	0 to 13 [12] -	<p style="text-align: center;"><i>Table 11.28: Forward/Reverse selection - Local situation</i></p> <table border="1"> <thead> <tr> <th>P223</th> <th>Function</th> </tr> </thead> <tbody> <tr> <td>0</td> <td>Always Forward.</td> </tr> <tr> <td>1</td> <td>Always Reverse.</td> </tr> <tr> <td>2</td> <td>HMI key (Forward default).</td> </tr> <tr> <td>3</td> <td>HMI key (Reverse default).</td> </tr> <tr> <td>4</td> <td>Digital Input DI2 (P264 = 0).</td> </tr> <tr> <td>5</td> <td>Serial (Forward default).</td> </tr> <tr> <td>6</td> <td>Serial (Reverse default).</td> </tr> <tr> <td>7</td> <td>Fieldbus (Forward default).</td> </tr> <tr> <td>8</td> <td>Fieldbus (Reverse default).</td> </tr> <tr> <td>9</td> <td>AI4 Polarity.</td> </tr> <tr> <td>10</td> <td>Forward PLC.</td> </tr> <tr> <td>11</td> <td>Reverse PLC.</td> </tr> <tr> <td>12</td> <td>Graphic HMI (Forward).</td> </tr> <tr> <td>13</td> <td>Graphic HMI (Reverse).</td> </tr> </tbody> </table>	P223	Function	0	Always Forward.	1	Always Reverse.	2	HMI key (Forward default).	3	HMI key (Reverse default).	4	Digital Input DI2 (P264 = 0).	5	Serial (Forward default).	6	Serial (Reverse default).	7	Fieldbus (Forward default).	8	Fieldbus (Reverse default).	9	AI4 Polarity.	10	Forward PLC.	11	Reverse PLC.	12	Graphic HMI (Forward).	13	Graphic HMI (Reverse).
P223	Function																															
0	Always Forward.																															
1	Always Reverse.																															
2	HMI key (Forward default).																															
3	HMI key (Reverse default).																															
4	Digital Input DI2 (P264 = 0).																															
5	Serial (Forward default).																															
6	Serial (Reverse default).																															
7	Fieldbus (Forward default).																															
8	Fieldbus (Reverse default).																															
9	AI4 Polarity.																															
10	Forward PLC.																															
11	Reverse PLC.																															
12	Graphic HMI (Forward).																															
13	Graphic HMI (Reverse).																															

Parameter	Range [Factory Setting] Unit	Description/Notes																														
P224 ⁽¹⁾ Start/Stop Selection LOCAL Situation	0 to 5 [0] -	<p>Table 11.29: Start/Stop selection – Local situation</p> <table border="1"> <thead> <tr> <th>P224</th> <th>Function</th> </tr> </thead> <tbody> <tr> <td>0</td> <td>HMI  and  keys.</td> </tr> <tr> <td>1</td> <td>Digital input DIx.</td> </tr> <tr> <td>2</td> <td>Serial.</td> </tr> <tr> <td>3</td> <td>Fieldbus.</td> </tr> <tr> <td>4</td> <td>PLC.</td> </tr> <tr> <td>5</td> <td>Graphic HMI.</td> </tr> </tbody> </table> <p>Note: When the DIx inputs have the FORWARD/REVERSE function, the keys  and  HMI will remain inactive regardless of the value set in P224.</p>	P224	Function	0	HMI  and  keys.	1	Digital input DIx.	2	Serial.	3	Fieldbus.	4	PLC.	5	Graphic HMI.																
P224	Function																															
0	HMI  and  keys.																															
1	Digital input DIx.																															
2	Serial.																															
3	Fieldbus.																															
4	PLC.																															
5	Graphic HMI.																															
P225 ⁽¹⁾ Selection of JOG Source LOCAL Situation	0 to 6 [6] -	<p>Table 11.30: JOG selection – Local situation</p> <table border="1"> <thead> <tr> <th>P225</th> <th>Function</th> </tr> </thead> <tbody> <tr> <td>0</td> <td>Disabled</td> </tr> <tr> <td>1</td> <td>HMI  key.</td> </tr> <tr> <td>2</td> <td>Digital inputs DI3 to DI10 (P265 to P272).</td> </tr> <tr> <td>3</td> <td>Serial.</td> </tr> <tr> <td>4</td> <td>Fieldbus.</td> </tr> <tr> <td>5</td> <td>PLC.</td> </tr> <tr> <td>6</td> <td>Graphic HMI.</td> </tr> </tbody> </table> <ul style="list-style-type: none"> The speed reference value for JOG is provided by parameter P122. 	P225	Function	0	Disabled	1	HMI  key.	2	Digital inputs DI3 to DI10 (P265 to P272).	3	Serial.	4	Fieldbus.	5	PLC.	6	Graphic HMI.														
P225	Function																															
0	Disabled																															
1	HMI  key.																															
2	Digital inputs DI3 to DI10 (P265 to P272).																															
3	Serial.																															
4	Fieldbus.																															
5	PLC.																															
6	Graphic HMI.																															
P226 ⁽¹⁾ Selection of Direction of ROTATION REMOTE Situation	0 to 13 [4] -	<p>Table 11.31: Selection of direction of rotation - Remote</p> <table border="1"> <thead> <tr> <th>P226</th> <th>Function</th> </tr> </thead> <tbody> <tr> <td>0</td> <td>Always Forward.</td> </tr> <tr> <td>1</td> <td>Always Reverse.</td> </tr> <tr> <td>2</td> <td>HMI  key (Forward default).</td> </tr> <tr> <td>3</td> <td>HMI  key (Reverse default).</td> </tr> <tr> <td>4</td> <td>Digital input DI2 (P264 = 0).</td> </tr> <tr> <td>5</td> <td>Serial (Forward default).</td> </tr> <tr> <td>6</td> <td>Serial (Reverse default).</td> </tr> <tr> <td>7</td> <td>Fieldbus (Forward default).</td> </tr> <tr> <td>8</td> <td>Fieldbus (Reverse default).</td> </tr> <tr> <td>9</td> <td>AI4 polarity.</td> </tr> <tr> <td>10</td> <td>Forward PLC.</td> </tr> <tr> <td>11</td> <td>Reverse PLC.</td> </tr> <tr> <td>12</td> <td>Graphic HMI (Forward Default).</td> </tr> <tr> <td>13</td> <td>Graphic HMI (Reverse Default).</td> </tr> </tbody> </table>	P226	Function	0	Always Forward.	1	Always Reverse.	2	HMI  key (Forward default).	3	HMI  key (Reverse default).	4	Digital input DI2 (P264 = 0).	5	Serial (Forward default).	6	Serial (Reverse default).	7	Fieldbus (Forward default).	8	Fieldbus (Reverse default).	9	AI4 polarity.	10	Forward PLC.	11	Reverse PLC.	12	Graphic HMI (Forward Default).	13	Graphic HMI (Reverse Default).
P226	Function																															
0	Always Forward.																															
1	Always Reverse.																															
2	HMI  key (Forward default).																															
3	HMI  key (Reverse default).																															
4	Digital input DI2 (P264 = 0).																															
5	Serial (Forward default).																															
6	Serial (Reverse default).																															
7	Fieldbus (Forward default).																															
8	Fieldbus (Reverse default).																															
9	AI4 polarity.																															
10	Forward PLC.																															
11	Reverse PLC.																															
12	Graphic HMI (Forward Default).																															
13	Graphic HMI (Reverse Default).																															

Parameter	Range [Factory Setting] Unit	Description/Notes																
P227 ⁽¹⁾ Start/Stop Selection – REMOTE Situation	0 to 5 [0] -	<p style="text-align: center;"><i>Table 11.32: Start/Stop selection – Remote situation</i></p> <table border="1" data-bbox="683 367 1355 607"> <thead> <tr> <th>P227</th> <th>Function</th> </tr> </thead> <tbody> <tr> <td>0</td> <td>HMI  and  keys.</td> </tr> <tr> <td>1</td> <td>Digital inputs DIx.</td> </tr> <tr> <td>2</td> <td>Serial.</td> </tr> <tr> <td>3</td> <td>Fieldbus.</td> </tr> <tr> <td>4</td> <td>PLC.</td> </tr> <tr> <td>5</td> <td>Graphic HMI.</td> </tr> </tbody> </table> <p>Note: If the Digital Inputs are programmed for Forward Run / Reverse, Run, the  and  keys will remain disabled, regardless of the value programmed at P227.</p>	P227	Function	0	HMI  and  keys.	1	Digital inputs DIx.	2	Serial.	3	Fieldbus.	4	PLC.	5	Graphic HMI.		
P227	Function																	
0	HMI  and  keys.																	
1	Digital inputs DIx.																	
2	Serial.																	
3	Fieldbus.																	
4	PLC.																	
5	Graphic HMI.																	
P228 ⁽¹⁾ JOG Selection - REMOTE Situation	0 to 6 [1] -	<p style="text-align: center;"><i>Table 11.33: JOG selection – Remote situation</i></p> <table border="1" data-bbox="683 826 1355 1066"> <thead> <tr> <th>P228</th> <th>Function</th> </tr> </thead> <tbody> <tr> <td>0</td> <td>Inactive.</td> </tr> <tr> <td>1</td> <td>HMI key.</td> </tr> <tr> <td>2</td> <td>Digital inputs DI3 to DI10 (P265 to P272).</td> </tr> <tr> <td>3</td> <td>Serial.</td> </tr> <tr> <td>4</td> <td>Fieldbus.</td> </tr> <tr> <td>5</td> <td>PLC.</td> </tr> <tr> <td>6</td> <td>Graphic HMI.</td> </tr> </tbody> </table> <ul style="list-style-type: none"> ■ The speed reference value for JOG is provided by parameter P122. 	P228	Function	0	Inactive.	1	HMI key.	2	Digital inputs DI3 to DI10 (P265 to P272).	3	Serial.	4	Fieldbus.	5	PLC.	6	Graphic HMI.
P228	Function																	
0	Inactive.																	
1	HMI key.																	
2	Digital inputs DI3 to DI10 (P265 to P272).																	
3	Serial.																	
4	Fieldbus.																	
5	PLC.																	
6	Graphic HMI.																	

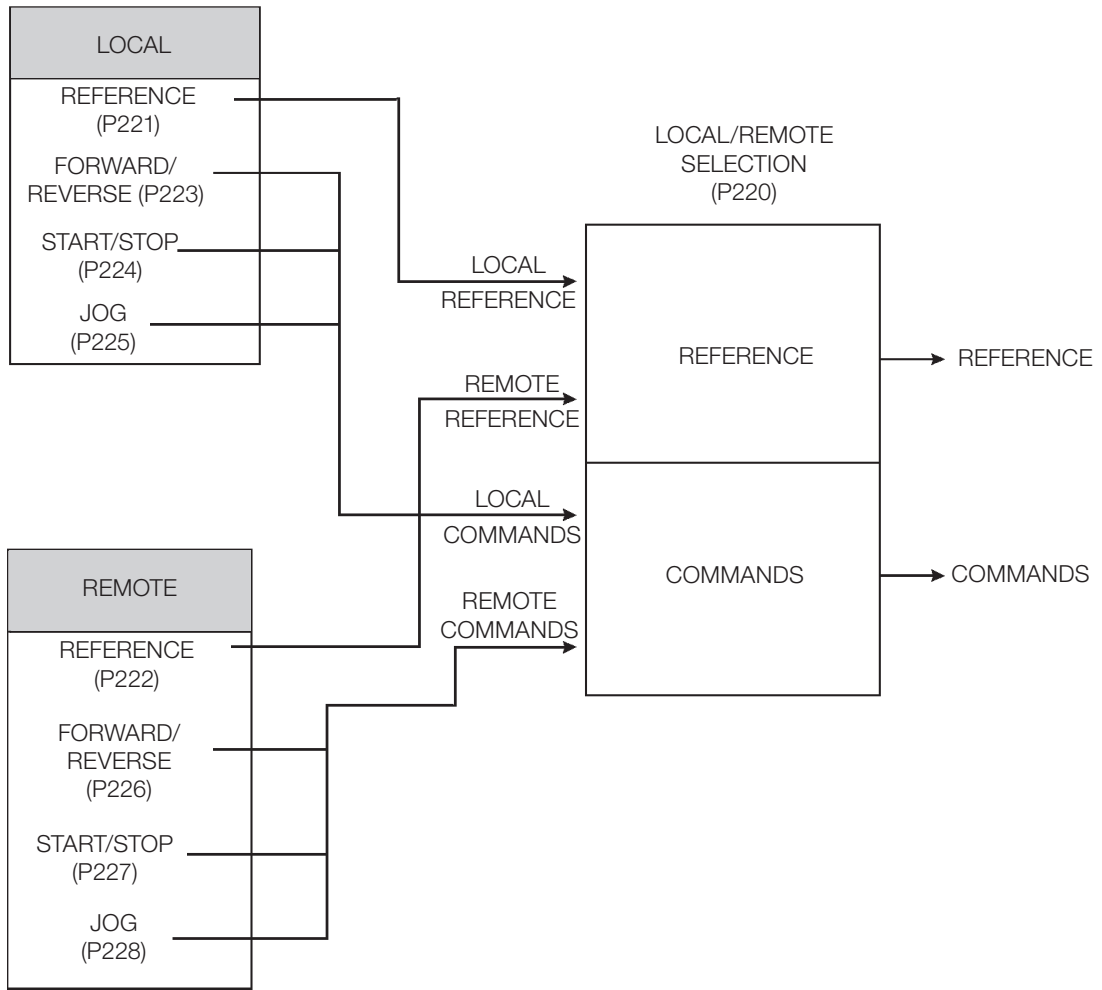

Figure 11.25: Local/Remote situation block diagram

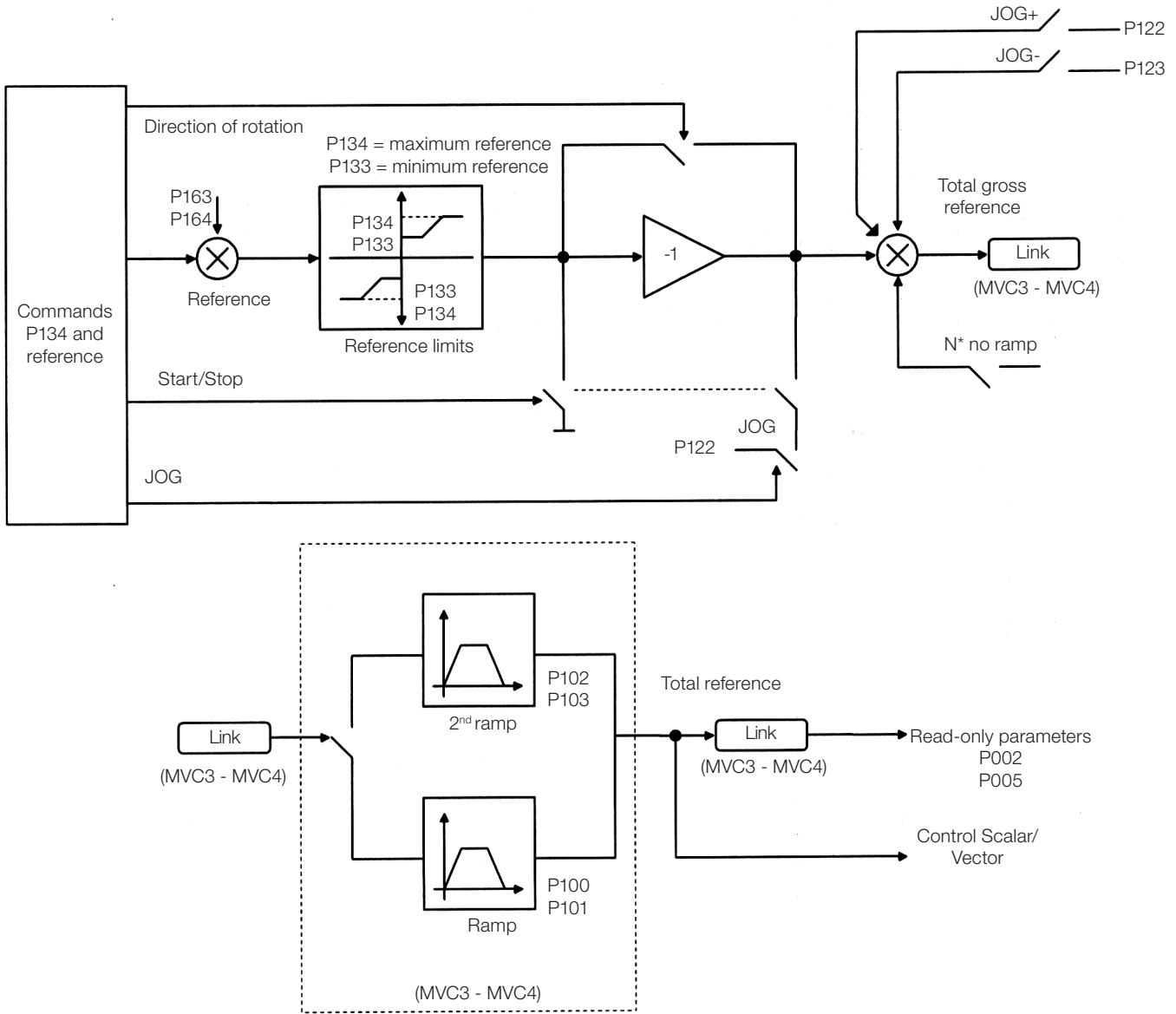

Figure 11.26: Speed reference block diagram

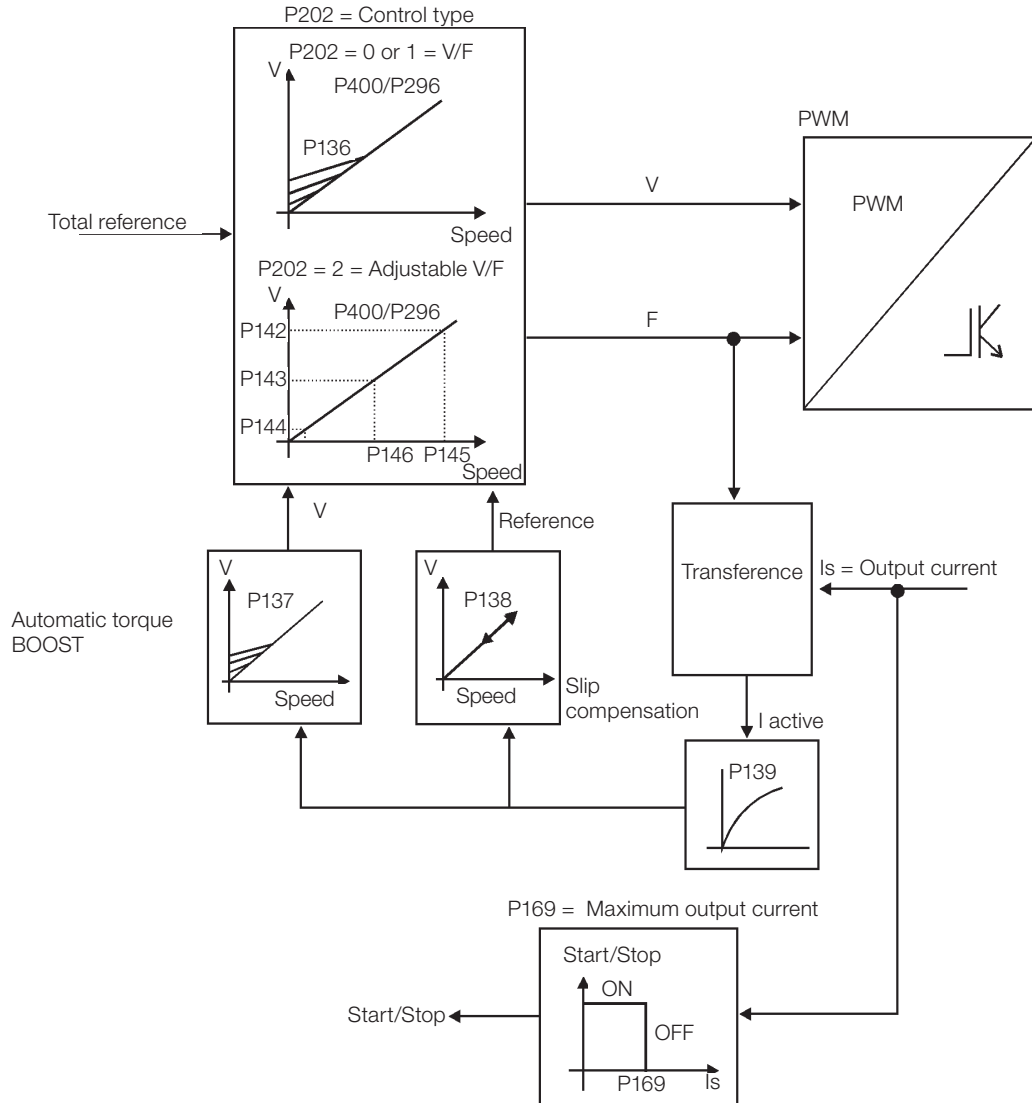

Figure 11.27: Block diagram of scalar control with sinusoidal output filter

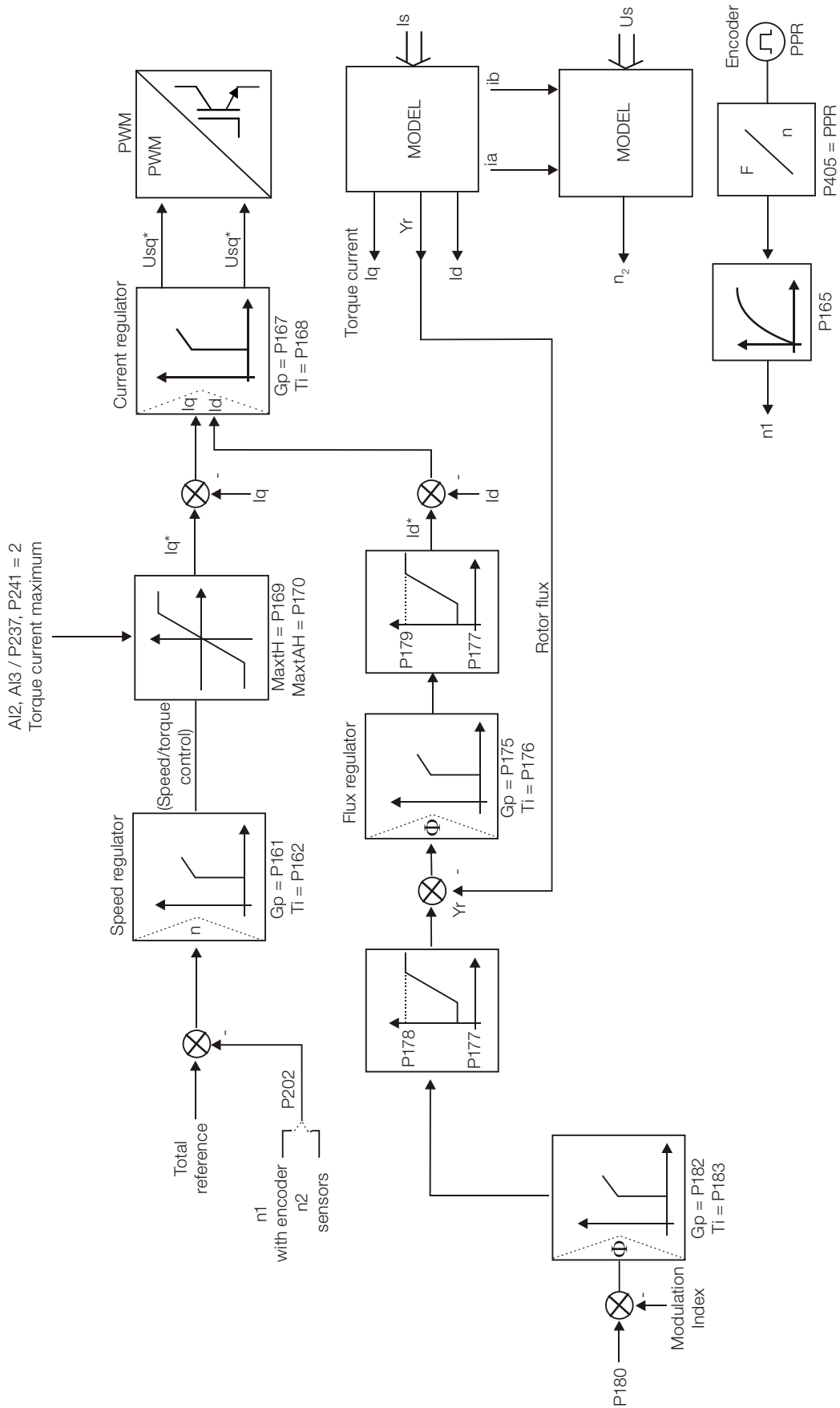

Figure 11.28: Vector control block diagram

Parameter	Range [Factory Setting] Unit	Description/Notes																		
P231 Actuation in the transition between Local and Remote for the HMIG	0 to 2 [0] -	<ul style="list-style-type: none"> P231 it defines the action to be taken by the inverter when the transition between LOCAL and REMOTE occurs for HMIG. This parameter only actuates when P224 = 5 or P227 = 5. <p style="text-align: center;"><i>Table 11.34: Stop mode selection</i></p> <table border="1" style="margin-left: auto; margin-right: auto;"> <thead> <tr> <th>P231</th> <th>Function</th> </tr> </thead> <tbody> <tr> <td>0</td> <td>It keeps the motor state</td> </tr> <tr> <td>1</td> <td>It keeps the HMI state</td> </tr> <tr> <td>2</td> <td>It turns off the motor *</td> </tr> </tbody> </table> <p>(*) The option P231 = 2 (Turn off the motor) actuates according to the programming of P232 (Stop mode selection).</p>	P231	Function	0	It keeps the motor state	1	It keeps the HMI state	2	It turns off the motor *										
P231	Function																			
0	It keeps the motor state																			
1	It keeps the HMI state																			
2	It turns off the motor *																			
P232 Stop Mode Selection	0 or 1 [0] -	<p style="text-align: center;"><i>Table 11.35: Stop mode selection</i></p> <table border="1" style="margin-left: auto; margin-right: auto;"> <thead> <tr> <th>P232</th> <th>Function</th> </tr> </thead> <tbody> <tr> <td>0</td> <td>Run/Stop</td> </tr> <tr> <td>1</td> <td>General Disable</td> </tr> </tbody> </table> <ul style="list-style-type: none"> With the P232 setting, it is possible to select between the stop modes (START/STOP and GENERAL DISABLE) for the key or for the STOP function (via DIx). <div style="border: 1px solid black; padding: 10px; margin-top: 10px;"> <p>NOTE! When the "DISABLE GENERAL" stop mode is programmed, only drive the motor if it is stopped or set the necessary time for which the inverter is disabled (COAST) in P725 to ensure the motor stop, or enable the Flystart function.</p> </div>	P232	Function	0	Run/Stop	1	General Disable												
P232	Function																			
0	Run/Stop																			
1	General Disable																			
P233 Analog Input Dead Zone	0 or 1 [1] -	<ul style="list-style-type: none"> It defines if the Dead Zone in the Analog Inputs is 0 = Inactive or 1 = Active. If P233 = 0 (Inactive), the signal in the Analog Inputs acts on the Speed Reference from the minimum point: <ul style="list-style-type: none"> (0 to 10) V/(0 to 20) mA/(4 to 20) mA:0 V/0 mA/4 mA. (10 to 0) V/(20 to 0) mA/(20 to 4) mA:10 V/20 mA/20 mA. If P233 = 1 (Active), the signal in the Analog Inputs has a dead zone, where the Speed Reference remains at the value of the Minimum Value (P133), even with the variation of the input signal. <div style="text-align: center; margin-top: 20px;"> <p>a) P233 = 0 inactive dead zone</p> <table style="margin-left: auto; margin-right: auto;"> <tr> <td>0</td> <td>.....</td> <td>10 V</td> </tr> <tr> <td>0</td> <td>.....</td> <td>20 mA</td> </tr> <tr> <td>4 mA</td> <td>.....</td> <td>20 mA</td> </tr> <tr> <td>10 V</td> <td>.....</td> <td>0</td> </tr> <tr> <td>20 mA</td> <td>.....</td> <td>0</td> </tr> <tr> <td>20 mA</td> <td>.....</td> <td>4 mA</td> </tr> </table> </div>	0	10 V	0	20 mA	4 mA	20 mA	10 V	0	20 mA	0	20 mA	4 mA
0	10 V																		
0	20 mA																		
4 mA	20 mA																		
10 V	0																		
20 mA	0																		
20 mA	4 mA																		

Figure 11.29: Analog input dead zone inactive

Parameter	Range [Factory Setting] Unit	Description/Notes
		<p>b) P233 = 1 Active dead zone</p> <p>Reference</p> <p>P134</p> <p>P133</p> <p>0</p> <p>Alx signal</p> <p>0 10 V 0 20 mA 4 mA 20 mA 10 V 0 20 mA 0 20 mA 4 mA</p> <p>Figure 11.30: Analog input dead zone active</p> <ul style="list-style-type: none"> ■ If the analog input AI2 or AI4 is programmed for -10 V to +10 V (P246 = 4), curves identical to those of the Figure 11.30 on page 11-52, only when AI2 or AI4 is negative will the Direction of Rotation be inverted.

<p>P234 Analog Input AI1 Gain</p>	<p>0.000 to 9.999 [1.000] 0.001</p>	<p>Read</p> <p>AI1' - P018</p> <p>AI3' - P020</p> <p>AI4' - P021</p> <p>AI5' - P028</p> <p>Alx</p> <p>P235 P243 P246 P723</p> <p>+</p> <p>+</p> <p>OFFSET (P236, P244, P247, P724)</p> <p>P234, P242, P245, P722</p> <p>GAIN</p>
--	---	--

Figure 11.31: Analog inputs AI1, AI3, AI4 and AI5 block diagram

- The internal values AI1', AI3', AI4' and AI5' are the results of the following equation:

$$Alx' = (Alx + \frac{OFFSET}{100} \times 10\text{ V}) \times \text{gain}$$

Example: AI1 = 5 V, OFFSET = -70 % and gain = 1.00:

$$AI1' = (5 + \frac{-70}{100} \times 10\text{ V}) \times 1 = -2\text{ V}$$

AI1' = -2 V, meaning that the motor will run in reverse direction with a speed reference absolute value equal to 2 V.

Parameter	Range [Factory Setting] Unit	Description/Notes										
P235 ⁽¹⁾ Analog Input AI1 Signal	0 to 3 [0] -	<p><i>Table 11.36: Analog input AI1 signal</i></p> <table border="1"> <thead> <tr> <th>P235</th> <th>Signal</th> </tr> </thead> <tbody> <tr> <td>0</td> <td>(0 to 10) V/(0 to 20) mA</td> </tr> <tr> <td>1</td> <td>(4 to 20) mA</td> </tr> <tr> <td>2</td> <td>(10 to 0) V/(20 to 0) mA</td> </tr> <tr> <td>3</td> <td>(20 to 4) mA</td> </tr> </tbody> </table> <ul style="list-style-type: none"> When current signals are used in AI1 input, put S2. A switch on the MVC4 control card in the "ON" position. For options 2 and 3 inverse reference is attained, that is, maximum speed is obtained with minimum reference. 	P235	Signal	0	(0 to 10) V/(0 to 20) mA	1	(4 to 20) mA	2	(10 to 0) V/(20 to 0) mA	3	(20 to 4) mA
P235	Signal											
0	(0 to 10) V/(0 to 20) mA											
1	(4 to 20) mA											
2	(10 to 0) V/(20 to 0) mA											
3	(20 to 4) mA											
P236 Analog Input AI1 Offset	-100.0 to +100.0 [0.0] 0.1%	<ul style="list-style-type: none"> Refer to the P234 description. 										
P237 ⁽¹⁾ Analog Input AI2 Function	0 to 3 [0] -	<p><i>Table 11.37: Analog input AI2 function</i></p> <table border="1"> <thead> <tr> <th>P237</th> <th>Function</th> </tr> </thead> <tbody> <tr> <td>0</td> <td>P221/P222</td> </tr> <tr> <td>1</td> <td>Without function</td> </tr> <tr> <td>2</td> <td>Maximum torque current</td> </tr> <tr> <td>3</td> <td>PID process variable</td> </tr> </tbody> </table> <ul style="list-style-type: none"> When the option 0 (P221/P222) is selected, AI2 is able to receive the speed reference, which will be subjected to the speed limits (P133 and P134) and ramp action (P100 to P103), providing that it has been programmed so in P221 and/or P222. Refer to the Figure 11.26 on page 11-48. The option 3, process variable, defines the AI2 input as the PID regulator feedback signal (e.g., pressure or temperature sensor, etc.), provided that P524 = 0. 	P237	Function	0	P221/P222	1	Without function	2	Maximum torque current	3	PID process variable
P237	Function											
0	P221/P222											
1	Without function											
2	Maximum torque current											
3	PID process variable											
P238 Analog Input AI2 Gain	0.000 to 9.999 [1.000] 0.001	<div style="text-align: center;"> </div> <p><i>Figure 11.32: Analog input AI2 block diagram</i></p> <ul style="list-style-type: none"> The internal value AI2' is the results of the following equation: $AI2' = (AI2 + \frac{OFFSET}{100} \times 10\text{ V}) \times \text{gain}$ For example: AI2 = 5 V, OFFSET = -70 % and gain = 1.00: $AI2' = (5 + \frac{-70}{100} \times 10\text{ V}) \times 1 = -2\text{ V}$ AI2' = -2 V, meaning that the motor will run in reverse direction with a speed reference absolute value equal to 2 V. 										

Parameter	Range [Factory Setting] Unit	Description/Notes												
		<ul style="list-style-type: none"> AI2 has a variation range from -10 V to 10 V, no matter if P239 = 0 or 4, that is, an input voltage of 0 V corresponds in P019 = 50 %. <p>If it is necessary that 0 V correspond to P019 = 0 %, the following setting must be done:</p> <p>P238 = 2 P240 = - 50 %</p>												
P239 ⁽¹⁾ Analog Input AI2 Signal	0 to 4 [0] -	<p><i>Table 11.38: Analog input AI2 signal</i></p> <table border="1"> <thead> <tr> <th>P239</th> <th>Signal</th> </tr> </thead> <tbody> <tr> <td>0</td> <td>(0 to 10) V/(0 to 20) mA</td> </tr> <tr> <td>1</td> <td>(4 to 20) mA</td> </tr> <tr> <td>2</td> <td>(10 to 0) V/(20 to 0) mA</td> </tr> <tr> <td>3</td> <td>(20 to 4) mA</td> </tr> <tr> <td>4</td> <td>(-10 to +10) V</td> </tr> </tbody> </table> <ul style="list-style-type: none"> Set the S2.B switch on the MVC4 control board to the on position when a current signal is used at the analog input AI2. Inverse reference is obtained with the options 2 and 3, i.e., the maximum speed is obtained with the minimum reference. 	P239	Signal	0	(0 to 10) V/(0 to 20) mA	1	(4 to 20) mA	2	(10 to 0) V/(20 to 0) mA	3	(20 to 4) mA	4	(-10 to +10) V
P239	Signal													
0	(0 to 10) V/(0 to 20) mA													
1	(4 to 20) mA													
2	(10 to 0) V/(20 to 0) mA													
3	(20 to 4) mA													
4	(-10 to +10) V													
P240 Analog Input AI2 Offset	-100.0 to +100.0 [0.0] 0.1%	<ul style="list-style-type: none"> Refer to the P238 description. 												
P241 ⁽¹⁾ Analog Input AI3 Function (Isolated Analog Input located on the Optional Board EBB. Refer to the Chapter 10 OPTIONAL ACCESSORIES AND BOARDS on page 10-1)	0 to 3 [0] -	<p><i>Table 11.39: Analog input AI3 function</i></p> <table border="1"> <thead> <tr> <th>P241</th> <th>Function</th> </tr> </thead> <tbody> <tr> <td>0</td> <td>P221/P222</td> </tr> <tr> <td>1</td> <td>Without function</td> </tr> <tr> <td>2</td> <td>Maximum torque current</td> </tr> <tr> <td>3</td> <td>PID process variable</td> </tr> </tbody> </table> <ul style="list-style-type: none"> When the option 0 (P221/P222) is selected, AI3 is able to receive the speed reference, which will be subjected to the speed limits (P133 and P134) and ramp action (P100 to P103), providing that it has been programmed so in P221 and/or P222. Refer to the Figure 11.26 on page 11-48. The option 3, process variable, defines the AI3 input as the PID regulator feedback signal (e.g., pressure or temperature sensor, etc.), provided that P524 = 1. 	P241	Function	0	P221/P222	1	Without function	2	Maximum torque current	3	PID process variable		
P241	Function													
0	P221/P222													
1	Without function													
2	Maximum torque current													
3	PID process variable													
P242 Analog Input AI3 Gain	0.000 to 9.999 [1.000] 0.001	<ul style="list-style-type: none"> Refer to the P234 description. 												

Parameter	Range [Factory Setting] Unit	Description/Notes												
P243 ⁽¹⁾ Analog Input AI3 Signal	0 to 3 [0] -	<p style="text-align: center;"><i>Table 11.40: Analog input AI3 signal type</i></p> <table border="1" style="margin-left: auto; margin-right: auto;"> <thead> <tr> <th>P243</th> <th>Signal</th> </tr> </thead> <tbody> <tr> <td>0</td> <td>(0 to 10) V/(0 to 20) mA</td> </tr> <tr> <td>1</td> <td>(4 to 20) mA</td> </tr> <tr> <td>2</td> <td>(10 to 0) V/(20 to 0) mA</td> </tr> <tr> <td>3</td> <td>(20 to 4) mA</td> </tr> </tbody> </table> <ul style="list-style-type: none"> Set the S4.1 switch on the EBB optional board to the on position when a current signal is used at the analog input AI3. Inverse reference is obtained with the options 2 and 3, i.e., the maximum speed is obtained with the minimum reference. 	P243	Signal	0	(0 to 10) V/(0 to 20) mA	1	(4 to 20) mA	2	(10 to 0) V/(20 to 0) mA	3	(20 to 4) mA		
P243	Signal													
0	(0 to 10) V/(0 to 20) mA													
1	(4 to 20) mA													
2	(10 to 0) V/(20 to 0) mA													
3	(20 to 4) mA													
P244 Analog Input AI3 Offset	-100.0 to +100.0 [0.0] 0.1%	<ul style="list-style-type: none"> Refer to the P234 description. 												
P245 Analog Input AI4 Gain (14 bit Analog Input located on the EBA Optional Board. Refer to the Chapter 10 OPTIONAL ACCESSORIES AND BOARDS on page 10-1)	0.000 to 9.999 [1.000] 0.001	<ul style="list-style-type: none"> Refer to the P234 description. 												
P246 ⁽¹⁾ Analog Input AI4 Signal	0 to 4 [0] -	<p style="text-align: center;"><i>Table 11.41: Analog input AI4 signal</i></p> <table border="1" style="margin-left: auto; margin-right: auto;"> <thead> <tr> <th>P246</th> <th>Signal</th> </tr> </thead> <tbody> <tr> <td>0</td> <td>(0 to 10) V/ (0 to 20) mA</td> </tr> <tr> <td>1</td> <td>(4 to 20) mA</td> </tr> <tr> <td>2</td> <td>(10 to 0) V/ (20 to 0) mA</td> </tr> <tr> <td>3</td> <td>(20 to 4) mA</td> </tr> <tr> <td>4</td> <td>(-10 to +10) V</td> </tr> </tbody> </table> <ul style="list-style-type: none"> Inverse reference is obtained with the options 2 and 3, i.e., the maximum speed is obtained with the minimum reference. When current signals are used in AI4 input, put S2.1 switch on the EBA optional card in the "ON" position. 	P246	Signal	0	(0 to 10) V/ (0 to 20) mA	1	(4 to 20) mA	2	(10 to 0) V/ (20 to 0) mA	3	(20 to 4) mA	4	(-10 to +10) V
P246	Signal													
0	(0 to 10) V/ (0 to 20) mA													
1	(4 to 20) mA													
2	(10 to 0) V/ (20 to 0) mA													
3	(20 to 4) mA													
4	(-10 to +10) V													
P247 Analog Input AI4 Offset	-100.0 to +100.0 [0.0] 0.1 %	<ul style="list-style-type: none"> Refer to the P234 description. 												
P248 Analog Input AI2 Filter	0.0 to 16.0 [0.0] 0.1 s	<ul style="list-style-type: none"> It adjusts the analog input AI2 RC filter time constant. (Refer to the Figure 11.32 on page 11-53). 												

Parameter	Range [Factory Setting] Unit	Description/Notes
P251 Analog Output AO1 Function	0 to 21 [2] -	<ul style="list-style-type: none"> See Table 11.42 on page 11-57 for further details related to the function of analog outputs. For values in the factory default (P251 = 2 and P252 = 1.000) AO1 = 10 V when Actual Speed = Maximum Speed (P134). AO1 output may be located on the control card MVC4 (0 to 10) V or on the optional card EBB [AO1', (0 to 20) mA/ (4 to 20) mA]. Refer to Chapter 10 OPTIONAL ACCESSORIES AND BOARDS on page 10-1. When EBB is used, the same signal is available for MVC4.
P252 Analog Output AO1 Gain	0.000 to 9.999 [1.000] 0.001	<ul style="list-style-type: none"> It adjusts the analog output AO1 gain. For a setting of P252 = 1.000, the AO1 value is adjusted according to the description of the analog output indication scales presented at P262 description.
P253 Analog Output AO2 Function	0 to 21 [5] -	<ul style="list-style-type: none"> Refer to Table 11.42 on page 11-57 for further details regarding the functions of the analog outputs. With factory default values (P253 = 5 and P254 = 1.000) AO2 = 10 V when the output current is = 1.5 x P295. The AO2 output can be located on the MVC4 control board (as 0 to 10 V) or on the option board EBB [AO2', (0 to 20) mA/ (4 to 20) mA]. Refer to the Chapter 10 OPTIONAL ACCESSORIES AND BOARDS on page 10-1. When EBB is used, the same signal is available for MVC4.
P254 Analog Output AO2 Gain	0.000 to 9.999 [1.000] 0.001	<ul style="list-style-type: none"> It adjusts the analog output AO2 gain. For a setting of P254 = 1.000, the AO2 value is adjusted according to the description of the analog output indication scales presented at P262 description.
P255 Analog Output AO3 Function (Located on the EBA optional board)	0 to 21 [2] -	<ul style="list-style-type: none"> Refer to the Table 11.42 on page 11-57 for further details regarding the functions of the analog outputs. With factory default values (P255 = 2 and P256 = 1.000) AO3 = 10 V when Actual Speed = Maximum Speed (P134). For information on the AO3 output, refer to Chapter 10 OPTIONAL ACCESSORIES AND BOARDS on page 10-1.
P256 Analog Output AO3 Gain	0.000 to 9.999 [1.000] 0.001	<ul style="list-style-type: none"> It adjusts the analog output AO3 gain. For a setting of P256 = 1.000, the AO3 value is adjusted according to the description of the analog output indication scales presented at P262 description.
P257 Analog Output AO4 Function (Located on the EBA optional board)	0 to 21 [5] -	<ul style="list-style-type: none"> Refer to Table 11.42 on page 11-57 for further details regarding the functions of the analog outputs. For values in the factory default (P257 = 5 and P258 = 1.000) AO4 = 10 V when Output Current = 1.5 x P295. For information on the AO4 output, refer to Chapter 10 OPTIONAL ACCESSORIES AND BOARDS on page 10-1.
P258 Analog Output AO4 Gain	0.000 to 9.999 [1.000] 0.001	<ul style="list-style-type: none"> It adjusts the analog output AO4 gain. For a setting of P258 = 1.000, the AO4 value is adjusted according to the description of the analog output indication scales presented at P262 description.

Parameter	Range [Factory Setting] Unit	Description/Notes
P259 Analog Output AO5 Function (isolated single-pole)	0 to 21 [2] -	<ul style="list-style-type: none"> Refer to Table 11.42 on page 11-57 for further details regarding the functions of the analog outputs. For values in the factory default (P259 = 2 and P260 = 1.000) AO5 = 20 mA when Actual Speed = Maximum Speed (P134).
P260 Analog Output AO5 Gain	0.000 to 9.999 [1.000] 0.001	<ul style="list-style-type: none"> It adjusts the analog output AO5 gain, for a setting of P260 = 1.000, the AO5 value is adjusted according to the description of the analog output indication scales presented at P262 description.
P261 Analog Output AO6 Function (isolated single-pole)	0 to 21 [5] -	<ul style="list-style-type: none"> Refer to Table 11.42 on page 11-57 for further details regarding the functions of the analog outputs. With factory default values (P261 = 5 and P262 = 1.000) AO6 = 20 mA when Output Current = 1.5 x P295.
P262 Analog Output AO6 Gain	0.000 to 9.999 [1.000] 0.001	<ul style="list-style-type: none"> It adjusts the analog output AO6 gain. For a setting of P262 = 1.000, the AO6 value is adjusted according to the description of the analog output indication scales presented here at P262 description.

Table 11.42: Analog output functions

Function	P251 (AO1)	P253 (AO2)	P255 (AO3)	P257 (AO4)	P259 (AO5)	P261 (AO6)	Full Scale (10 V)
Speed Reference	0	0	0	0	0	0	1 x P134
Total Reference	1	1	1	1	1	1	1 x P134
Actual Speed	2	2	2	2	2	2	1 x P134
Not Used	3/4	3/4	3/4	3/4	3/4	3/4	
Output Current (with 0.5 sec filter)	5	5	5	5	5	5	1.5 x P295
PID Process Variable	6	6	6	6	6	6	1 x P528
Output Active Current	7	7	7	7	7	7	100 % P295/P401
Real Power in the Output	8	8	8	8	8	8	2 x P295 x P296 x $\sqrt{3}$
PID Reference	9	9	9	9	9	9	1 x P528
Not Used	10	10	10	10	10	10	
Trace Channels 1 to 8	11 to 18	11 to 18	11 to 18	11 to 18	11 to 18	11 to 18	Same parameter chosen
Inverter Temperature	19	19	19	19	19	19	200 °C
PLC	20	20	20	20	20	20	
Output Voltage	21	21	21	21	21	21	1 x P296

Parâmetro	Faixa [Ajuste de Fábrica] Unidade	Descrição / Observações
		<p>Figure 11.33: Analog outputs block diagram</p> <ul style="list-style-type: none"> ■ Analog output indication scales: <ul style="list-style-type: none"> - Full scale of 10 V for AO1 and AO2 outputs located on the MVC4 control board, and for AO3 and AO4 located on the EBA optional board. - Full scale of 20 mA for AO1' and AO2' outputs located on the EBB optional board, and for AO5 and AO6 located on the MVC4 control board. Speed reference (P001): full scale = P134. Total reference: full scale = P134. Actual speed (P002): full scale = P134. Output current: full scale = 1.5 x P295. PID process variable: full scale = 1.0 x P528. PID reference: full scale = 1.0 x P528. Inverter temperature = 200 °C. Output power: full scale = 2.0 x P295 x P296 x $\sqrt{3}$.

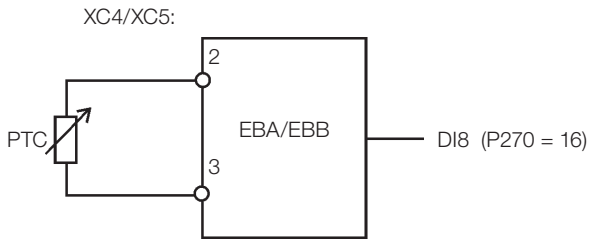
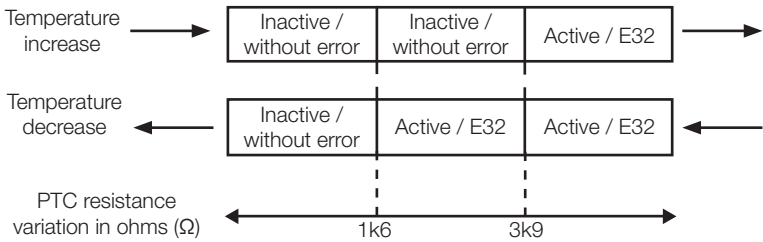
Parâmetro	Faixa [Ajuste de Fábrica] Unidade	Descrição / Observações
P263 ⁽¹⁾ Digital Input DI1 Function	0 to 3 [0 (Not used)] -	<ul style="list-style-type: none"> Refer to the Table 11.43 on page 11-62 and the Figure 11.34 on page 11-59 and Figure 11.37 on page 11-61 for further details regarding the functions of the digital inputs. The digital input status can be monitored at the parameter P012. <p>Notes:</p> <p>'Increase EP' (Electronic Potentiometer) is active when DI3 or DI5 are closed = +24 V.</p> <p>'Decrease EP' (Electronic Potentiometer) is active when DI4 or DI6 are open = 0 V.</p> <p>'LOCAL/REMOTE' = 0 V/24 V in the digital input respectively.</p> <p>DI8 digital input is linked to the input for 'Motor Thermistor' (PTC) present on the EBA/EBB optional cards:</p>  <p style="text-align: center;">XC4/XC5:</p>  <p style="text-align: center;">Figure 11.34: DI8 as a PTC input</p>
P264 ⁽¹⁾ Digital Input DI2 Function	0 or 1 [0 (Forward/Reverse)] -	
P265 ⁽¹⁾ Digital Input DI3 Function	0 to 26 [0 (Not used)] -	
P266 ⁽¹⁾ Digital Input DI4 Function	0 to 26 [0 (Not used)] -	
P267 ⁽¹⁾ Digital Input DI5 Function	0 to 26 [3 (JOG)] -	
P268 ⁽¹⁾ Digital Input DI6 Function	0 to 26 [6 (2 nd ramp)] -	
P269 ⁽¹⁾ Digital Input DI7 Function (Located on the optional board)	0 to 24 [0 (Not used)] -	
P270 ⁽¹⁾ Digital Input DI8 Function (Located on the optional board)	0 to 24 [0 (Not used)] -	

Parâmetro	Faixa [Ajuste de Fábrica] Unidade	Descrição / Observações
-----------	-----------------------------------	-------------------------

P271 ⁽¹⁾
Digital Input DI9
Function

0 to 24
[0 (Not used)]
-

P272 ⁽¹⁾
Digital Input DI10
Function

0 to 24
[0 (Not used)]
-

- In order to use the DI8 as a normal digital input, program the designated function at P270, and connect a resistor, ranging from 270 to 1600 Ω, in series with the contact:

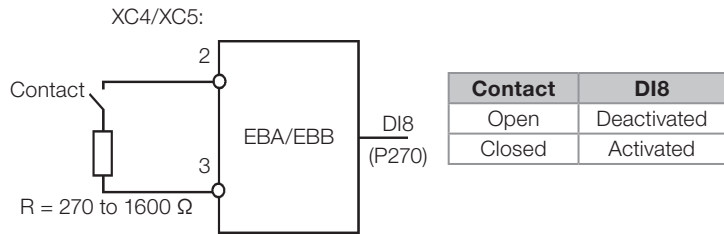

Figure 11.35: DI8 as a normal digital input

- The function 'Load User via DIx' allows the selection between the user memories 1 and 2, performing actions similar to the setting of P204 = 7 or 8; however, the user memories are loaded by the transition of a digital input programmed for that function.
- When the DIx state changes from low to high level (transition from 0 V to 24 V), and P265 to P270 = 20, the user memory 1 is loaded, provided that the contents of the inverter actual parameters had been previously transferred to the user memory 1 (P204 = 10).
- When the DIx state changes from high to low level (transition from 24 V to 0 V) and P265 to P270 = 20, the user memory 2 is loaded, provided that the contents of the inverter actual parameters had been previously transferred to the user memory 2 (P204 = 11).

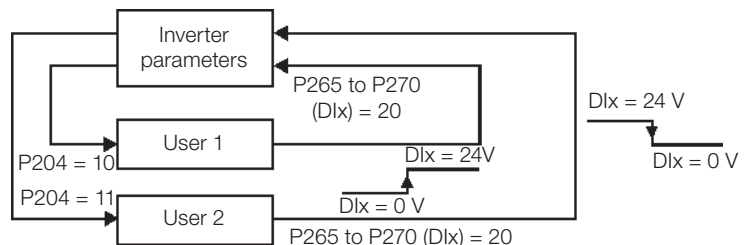

Figure 11.36: Details on the load user via DIx operation



NOTE!

Make sure that when using those functions the parameter sets (user memory 1 and 2) be entirely compatible with the application (motors, Start/Stop commands, etc.). It will not be possible to load the user memory with the motor enabled. If two parameter sets from different motors were saved in the user memories 1 and 2, the correct motor current values for each user memory must be adjusted at the parameters P156, P157 and P158.

Parâmetro	Faixa [Ajuste de Fábrica] Unidade	Descrição / Observações
		<ul style="list-style-type: none"> - If the function 'Parameterization Disabling' is programmed and the correspondent DIx in +24 V input is closed, then parameter changes are not allowed, regardless of P000 and P200 settings. When the DIx input is open, parameter changes are conditioned to P000 and P200 settings. - 'RL2 and RL3 Timer': this function acts as a timer to activate and deactivate the relays 2 and 3 (RL2 and RL3). When the timer function for the relay 2 or 3 is programmed at any DIx, and a transition from open to closed occurs, the programmed relay will be activated with the delay set in P283 (RL2) or P285 (RL3). When a transition from closed to open occurs, the programmed relay will be deactivated with the delay adjusted in P284 (RL2) or P286 (RL3). After the transition of the DIx, either for activating or deactivating the programmed relay, it is necessary that the DIx remains closed or open during at least the time set in P283/P285 and P284/P286. Otherwise, the timer will be reset. Refer to the Figure 11.37 on page 11-61. <p>Note: In order to enable that function it is also necessary to program P279 and/or P280 = 29 (Timer).</p> <div data-bbox="724 1048 1481 1276" data-label="Figure"> </div> <p style="text-align: center;"><i>Figure 11.37: RL2 and RL3 timer function operation</i></p> <ul style="list-style-type: none"> - The 'Ventilation OK' function generates an inverter ventilation fault (F048). <div data-bbox="724 1451 1485 1637" data-label="Figure"> </div> <p style="text-align: center;"><i>Figure 11.38: Ventilation OK function operation</i></p>
		<p>Feedback of the sinusoidal filter circuit breaker</p> <ul style="list-style-type: none"> ■ In order to improve the degree of protection of the opening function of the sinusoidal filter circuit breaker, a new function was created for the DI of the opening feedback. This DI waits for 1 second after the closing signal of the circuit breaker, and then it starts monitoring the feedback signal. If an error occurs in this closing device, fault F013 is activated. Diagram of Figure 11.39 on page 11-66 describes the operation of this new function. For details on fault F013, refer to Chapter 14 DIAGNOSTICS AND TROUBLESHOOTING on page 14-1.

Table 11.43: Digital input functions

Function	Parameter Dlx	P263 (DI1)	P264 (DI2)	P265 (DI3)	P266 (DI4)	P267 (DI5)	P268 (DI6)	P269 (DI7)	P270 (DI8)	P271 (DI9)	P272 (DI10)
Not used		0	-	0, 7, 17 and 18	0, 17 and 18	0, 17 and 18	0, 17 and 18	0, 5, 7, 9, 16, 17 and 18	0, 5, 7, 9, 17 and 18	0, 5, 7, 9, 17 and 18	0, 5, 7, 9, 17 and 18
Start/Stop		1	-	-	-	-	-	-	-	-	-
General Enable		2	-	2	2	2	2	2	2	2	2
Fast Stop		3	-	-	-	8	8	8	8	8	8
Forward/Reverse		-	0	-	-	-	-	-	-	-	-
Local/Remote		-	1	1	1	1	1	1	1	1	1
JOG		-	-	3	3	3	3	3	3	3	3
No External Fault		-	-	4	4	4	4	4	4	4	4
Increase EP		-	-	5	-	5	-	-	-	-	-
Decrease EP		-	-	-	5	-	5	-	-	-	-
2 nd Ramp		-	-	6	6	6	6	6	6	6	6
Multispeed (MSx)		-	-	-	7	7	7	-	-	-	-
Forward Run		-	-	8	-	-	-	-	-	-	-
Reverse Run		-	-	-	8	-	-	-	-	-	-
Sinusoidal Filter Circuit Breaker		-	-	9	9	9	9	-	-	-	-
JOG+		-	-	10	10	10	10	10	10	10	10
JOG-		-	-	11	11	11	11	11	11	11	11
Reset		-	-	12	12	12	12	12	12	12	12
Fieldbus		-	-	13	13	13	13	13	13	13	13
Start		-	-	14	-	14	-	14	-	-	-
Stop		-	-	-	14	-	14	-	14	14	14
Manual/Automatic		-	-	15	15	15	15	15	15	15	15
No External Alarm		-	-	16	16	16	16	-	-	16	16
Motor Thermistor		-	-	-	-	-	-	-	16	-	-
Parameterization Disabling		-	-	19	19	19	19	19	19	-	-
Load User 1/2		-	-	20	20	20	20	20	20	-	-
RL2 Timer		-	-	21	21	21	21	21	21	-	-
RL3 Timer		-	-	22	22	22	22	22	22	-	-
No Motor Fault		-	-	-	-	-	-	-	-	19	19
No Motor Alarm		-	-	-	-	-	-	-	-	20	20
No Alarm in the Redundant Ventilation Set A		-	-	23	23	23	23	-	-	21	21
No Alarm in the Redundant Ventilation Set B		-	-	24	24	24	24	-	-	22	22
Initiates Synchronous Transfer		-	-	25	25	25	25	23	23	23	23
Ventilation OK		-	-	26	26	26	26	24	24	24	24



NOTE!

In order that Start/Stop works, program also P224 and/or P227 = 1.
 The selection of P265 or P267 = 5, and P266 or P268 = 5, also requires the programming of P221 and/or P222 = 7.
 The programming of P266 and/or P267 and/or P268 = 7 also requires the programming of P221 and/or P222 = 8.

a) START/STOP

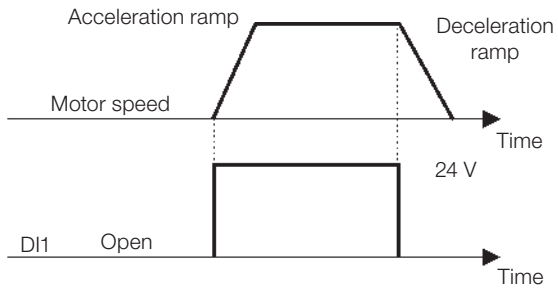

Note: All the inputs programmed for General Enable must be closed, so that the MVW-01 operates as showed above

b) GENERAL ENABLE

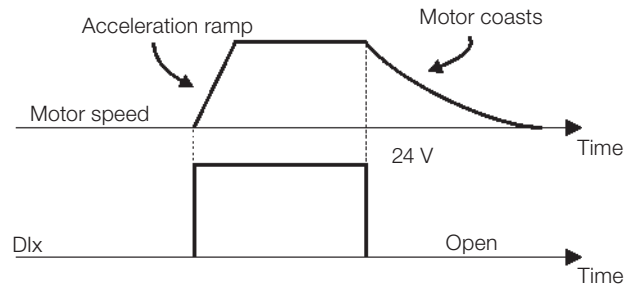

Note: All the inputs programmed for Start/Stop must be closed, so that the MVW-01 operates as showed above

c) NO EXTERNAL FAULT

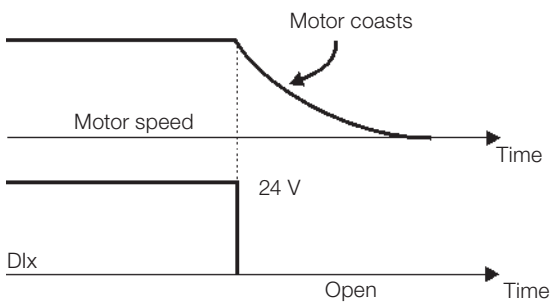

d) FORWARD/REVERSE

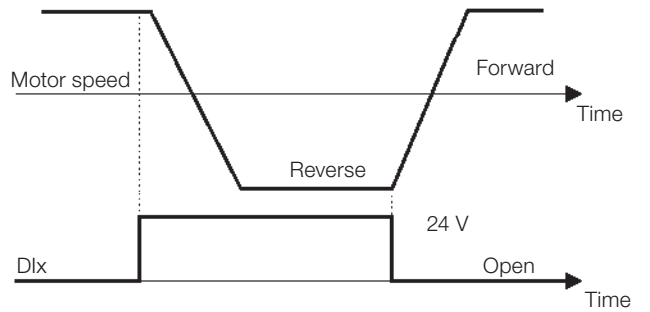

e) 2nd RAMP

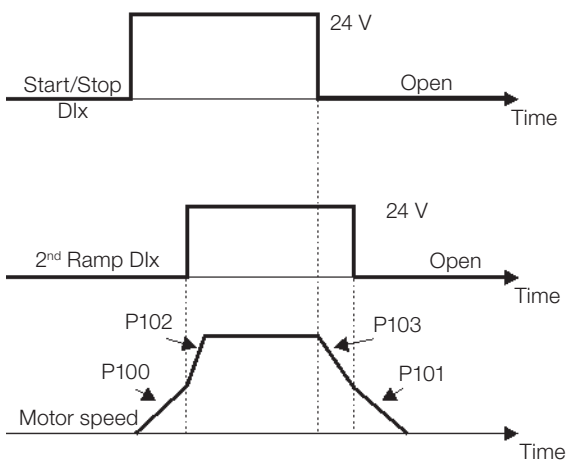

f) LOAD USER VIA DIX

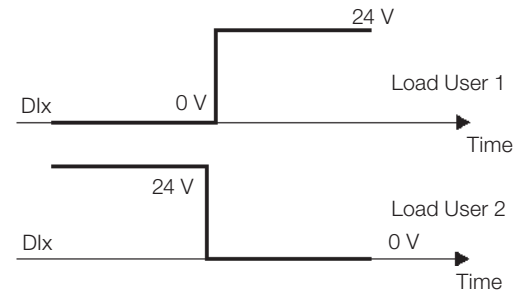

g) JOG

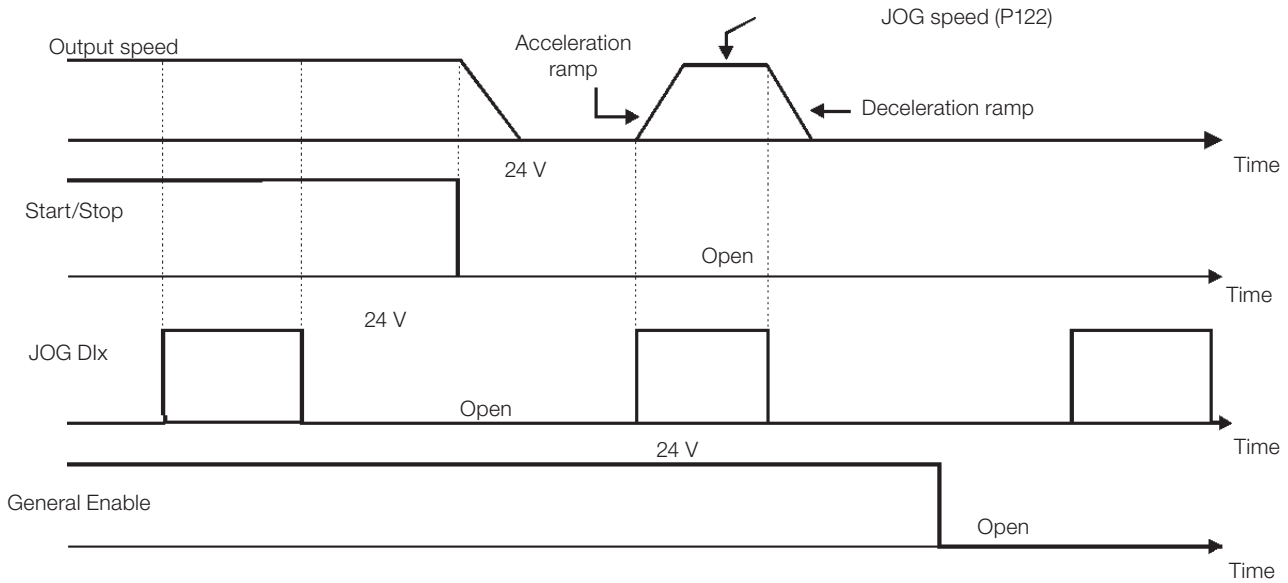

h) JOG+ AND JOG-

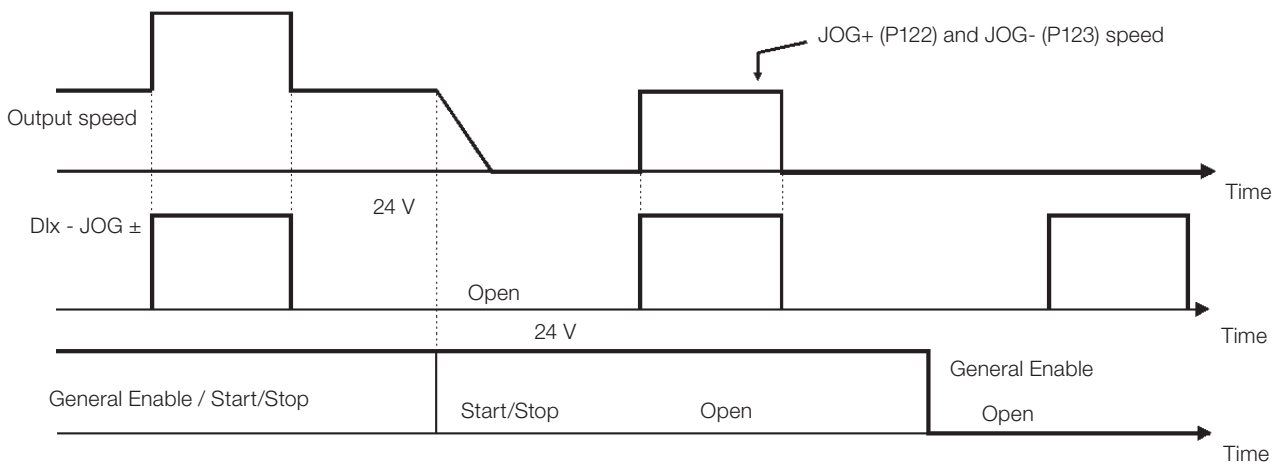

i) RESET

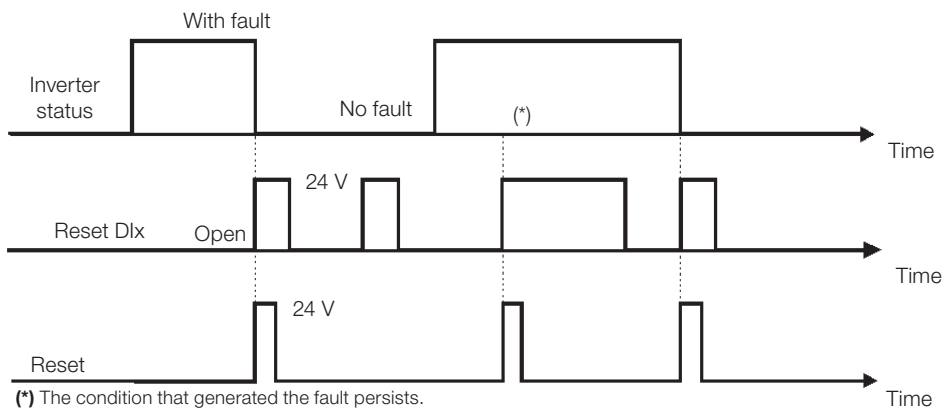

j) 3-WIRE START/STOP

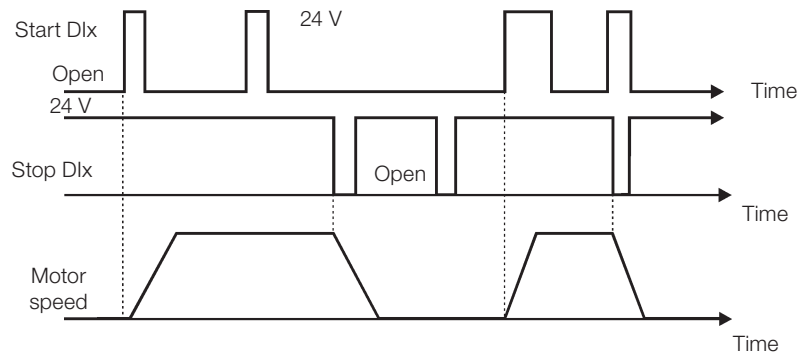

k) FORWARD RUN/REVERSE RUN

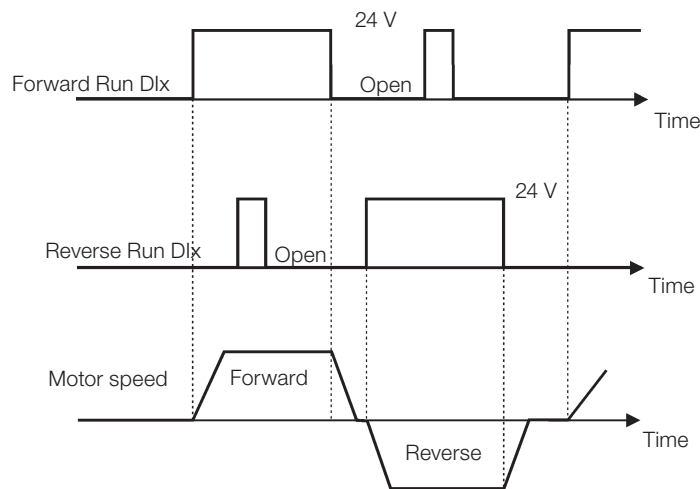

l) ELECTRONIC POTENTIOMETER (EP)

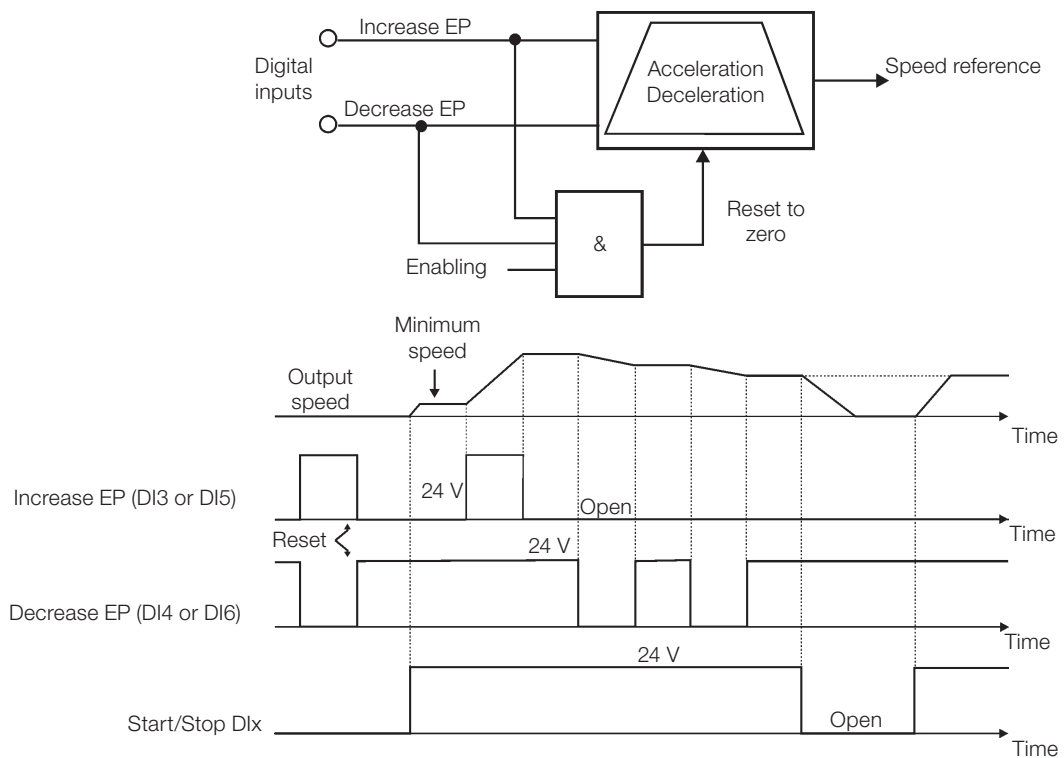

m) FEEDBACK OF THE SINUSOIDAL FILTER CIRCUIT BREAKER

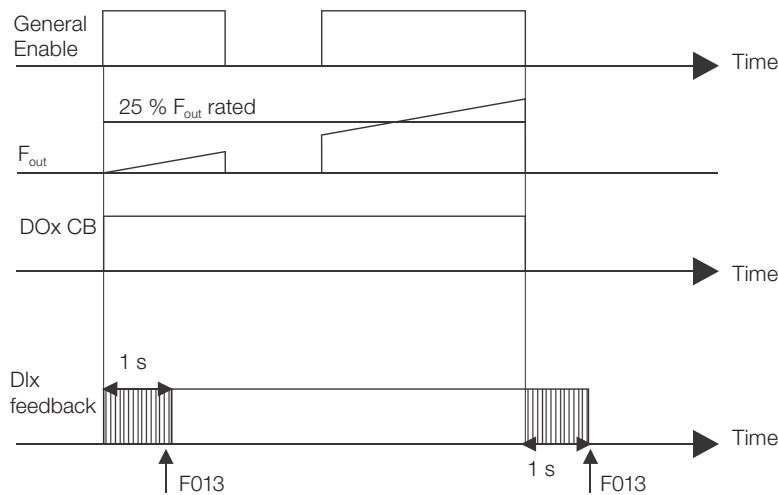

Figure 11.39: (a) to (m) Details on the operation of the digital input functions

Parameter	Range [Factory Setting] Unit	Description/Notes
P275 ⁽¹⁾ Digital Output DO1 Function (Located on the Optional Board)	0 to 38 [0 (Not used)] -	<ul style="list-style-type: none"> For more details about the digital and relay output, refer to Table 11.44 on page 11-68 and Figure 11.40 on page 11-70. The digital and relay output status can be monitored at the parameter P013. When the condition declared by the function is true, the digital output will be activated, i.e., a saturated transistor at a DOx output and/or a relay with energized coil for a RLx output.
P276 ⁽¹⁾ Digital Output DO2 Function (Located on the Optional Board)	0 to 38 [0 (Not used)] -	<ul style="list-style-type: none"> Example: $I_s > I_x$ function – when $I_s > I_x$, then DOx = saturated transistor and/or RLx = relay with the coil energized. When $I_s \leq I_x$ then DOx = open transistor and/or RLx = relay with the coil not energized.
P277 ⁽¹⁾ Relay Output RL1 Function	0 to 38 [13 (No fault)] -	<p>Notes:</p> <ul style="list-style-type: none"> 'Not used': it means that the digital outputs will remain always in a resting state, i.e., DOx = open transistor and/or RLx = relay with the coil not energized.
P279 ⁽¹⁾ Relay Output RL2 Function	0 to 38 [2 (N>Nx)] -	<ul style="list-style-type: none"> 'N = 0' it means that the motor speed is below the value adjusted in P291 (Zero Speed Zone).
P280 ⁽¹⁾ Relay Output RL3 Function	0 to 38 [1 (N*>Nx)] -	<ul style="list-style-type: none"> 'Remote' it means that the inverter is operating in Remote situation. 'Run' it corresponds to enabled inverter. In this state, the IGBTs are commutating, and the motor may be at any speed, even zero speed.
P281 ⁽¹⁾ Relay Output RL4 Function	0 to 38 [0 (Not used)] -	<ul style="list-style-type: none"> 'Ready' it corresponds to the inverter without error and without undervoltage. 'No Fault' it means that the inverter is not disabled by any type of fault.
P282 ⁽¹⁾ Relay Output RL5 Function	0 to 38 [0 (Not used)] -	<ul style="list-style-type: none"> 'No F070 + F071' it means that the inverter is not disabled by faults F070 or F071. 'No E003+E006+E021+E022' means the inverter is not disabled by error E003, E006, E021 or E022. 'No E011+E020+E051+E054+E057+E060+E062' means the inverter is not disabled by error E011, E020, E051, E054, E057, E060 or E062. 'No E072': means the inverter is not disabled by error E072. '4 to 20 mA Reference OK' it means that the reference in current is within the 4 to 20 mA range.

Parameter	Range [Factory Setting] Unit	Description/Notes
		<ul style="list-style-type: none"> - 'Forward' it means that when the motor is rotating in the forward direction, the DOx = saturated transistor and/or RLx = relay with the coil energized. When the motor is rotating in the reverse direction, the DOx = open transistor and/or RLx = relay with the coil not energized. - 'Pre-charge OK' it means that the DC Link voltage is above the pre-charge voltage level. - 'Fault' it means that the inverter is disabled by a fault. - 'N > Nx and Nt > Nx' it means that both the conditions must be satisfied, so that DOx = saturated transistor and/or RLx = relay with the coil energized. In order that the digital outputs go back to the resting state, i.e., DOx = open transistor and/or RLx = relay with the coil not energized, it is necessary that only the condition N > Nx not be satisfied anymore (regardless of the Nt > Nx condition). <p>Definition of the symbols used with the functions:</p> <ul style="list-style-type: none"> - N = P002 (Motor Speed). - N* = P001 (Speed Reference). - Nx = P288 (Nx Speed) - It is a reference point of the speed selected by the user. - Ny = P289 (Ny Speed) - It is a reference point of the speed selected by the user. - Ix = P290 (Ix Current) - It is a reference point of the current selected by the user. - Is = P003 (Motor Current) Torque = P009 (Motor Torque) - Tx = P293 (Tx Torque) - It is a reference point of the torque selected by the user. <p>Note: Function not implemented in this software version.</p> <ul style="list-style-type: none"> - VPx = P533 (PVx Process Variable) - It is a reference point of the process variable selected by the user. - VPy = P534 (Variável Processo y) - It is a reference point of the process variable selected by the user. - Nt = Total Reference (refer to the Figure 11.26 on page 11-48). - Safety Stop. - Sinusoidal Filter Circuit Breaker. - Normal Slave.

Table 11.44: Digital and relay output functions

Function	Dlx Parameter	P275 (DO1)	P276 (DO2)	P277 (RL1)	P279 (RL2)	P280 (RL3)	P281 (RL4)	P282 (RL5)
	Not used	0, 8, 9, 23 and 29	0, 8, 9, 23 and 29	0, 8, 9, 23 and 29	0, 8, 9 and 23	0, 8, 9 and 23	0, 8, 9, 23 and 29	0, 8, 9, 23 and 29
	N* > Nx	1	1	1	1	1	1	1
	N > Nx	2	2	2	2	2	2	2
	N < Ny	3	3	3	3	3	3	3
	N = N*	4	4	4	4	4	4	4
	N = 0	5	5	5	5	5	5	5
	Is > Ix	6	6	6	6	6	6	6
	Is < Ix	7	7	7	7	7	7	7
	Remote	10	10	10	10	10	10	10
	Run	11	11	11	11	11	11	11
	Ready	12	12	12	12	12	12	12
	No Fault	13	13	13	13	13	13	13
	No E070+E071	14	14	14	14	14	14	14
	No E003+E006+E021+E022	15	15	15	15	15	15	15
	No E011+E020+E051+E054+E057+E060+E062	16	16	16	16	16	16	16
	No E072	17	17	17	17	17	17	17
	4 to 20 mA OK	18	18	18	18	18	18	18
	Fieldbus	19	19	19	19	19	19	19
	Forward	20	20	20	20	20	20	20
	Process Variable > VPx	21	21	21	21	21	21	21
	Process Variable < VPy	22	22	22	22	22	22	22
	Pre-charge OK	24	24	24	24	24	24	24
	Fault	25	25	25	25	25	25	25
	N > Nx and Nt > Nx	26	26	26	26	26	26	26
	Without error with delay	27	27	27	27	27	27	27
	No Alarm	28	28	28	28	28	28	28
	Timer	-	-	-	29	29	-	-
	Redundant ventilation	30	30	30	30	30	30	30
	PLC	-	-	31	31	31	-	-
	Circuit Break ON (Input Circuit Breaker ON)	32	32	32	32	32	32	32
	Transference OK	33	33	33	33	33	33	33
	Synchronism OK	34	34	34	34	34	34	34
	Serial	35	35	35	35	35	35	35
	Safety Stop	36	36	36	36	36	36	36
	Sinusoidal Filter Circuit Breaker	37	37	37	37	37	37	37
	Normal/Slave	38	38	38	38	38	38	38

a) $N > N_x$

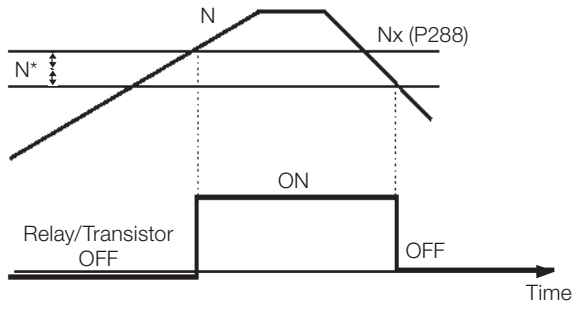

b) $N < N_y$

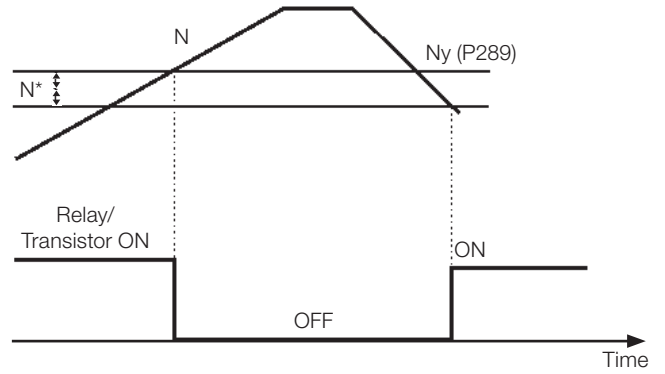

c) $N = N^*$

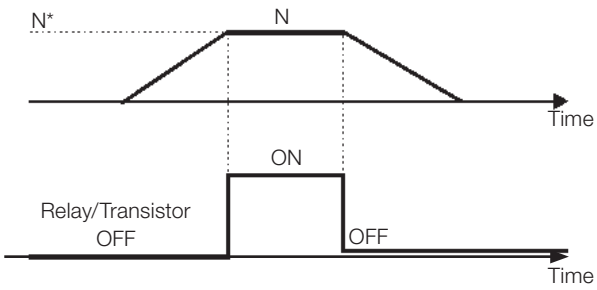

d) $I_s > I_x$

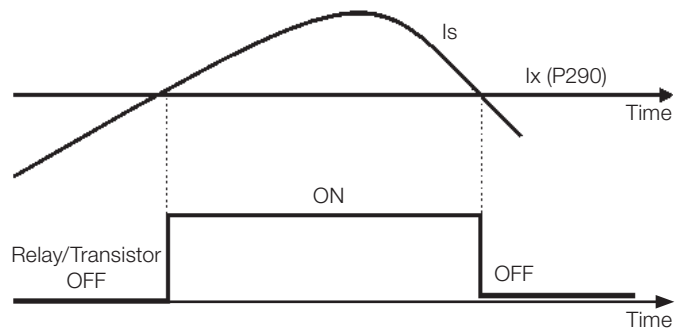

e) $N^* > N_x$

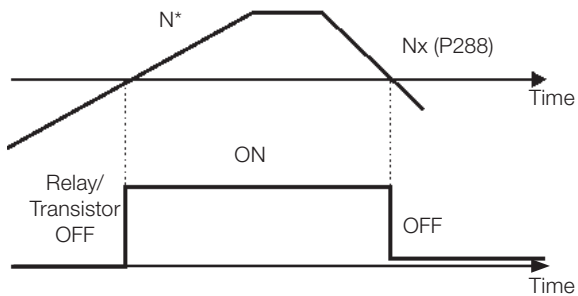

f) $I_s < I_x$

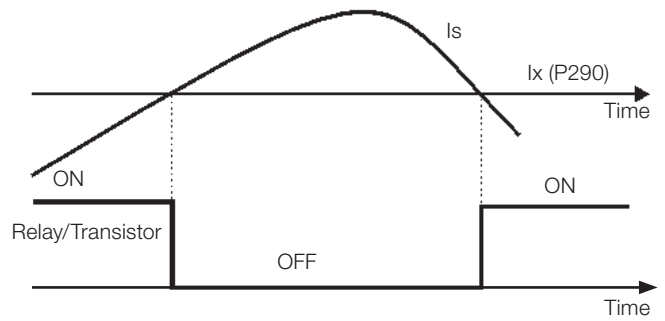

g) Torque < T_x

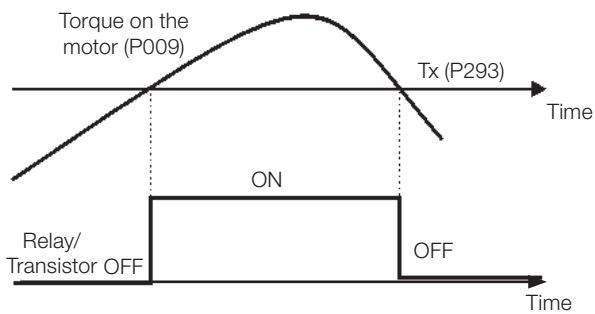

h) Torque < T_x

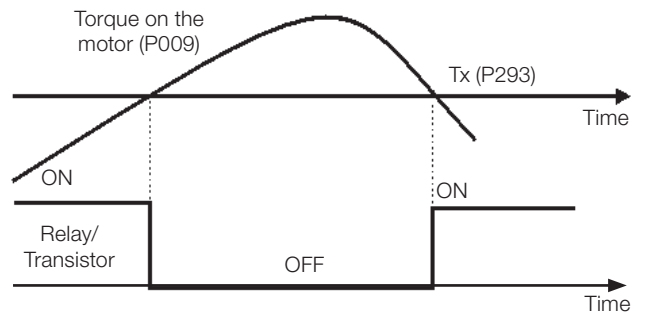

i) $N > N_x$ and $N_t > N_x$

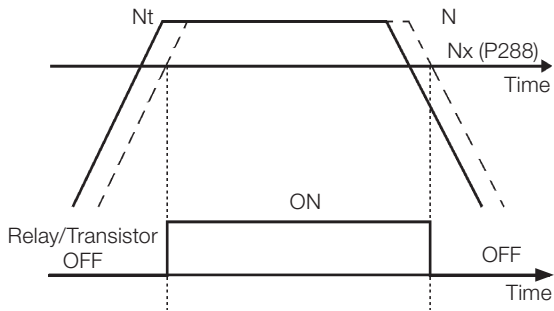

j) No external error

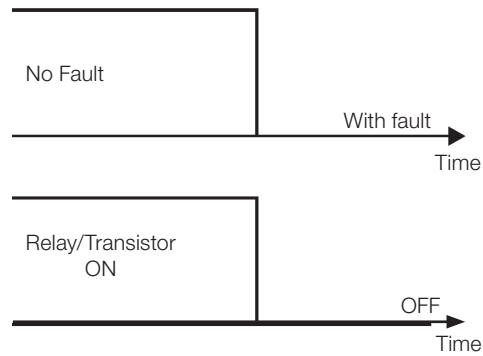

k) 4 to 20 mA reference

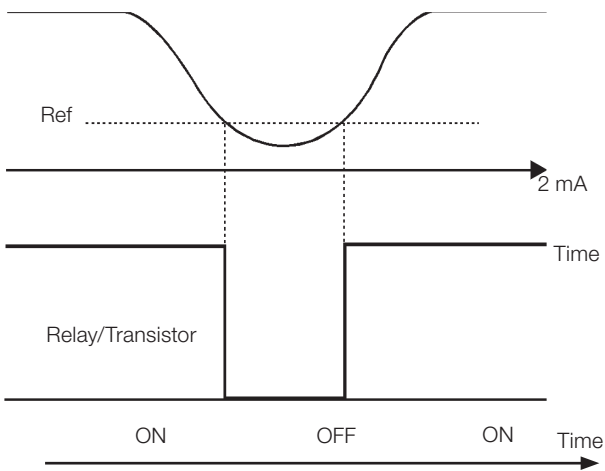

l) $N = 0$

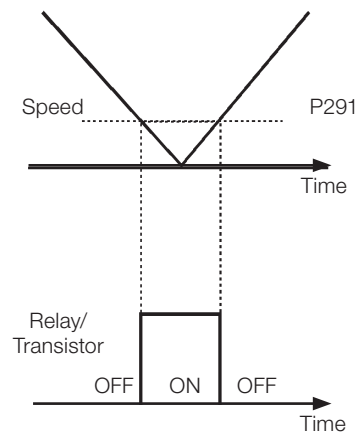

m) Process variable $X > VP_x$

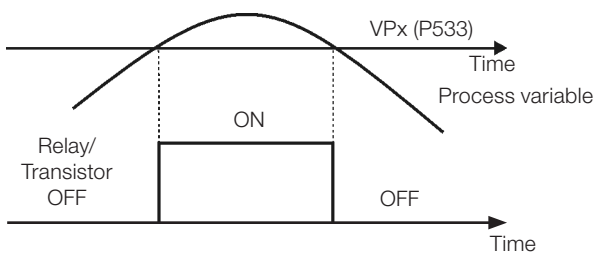

n) Pre-charge OK

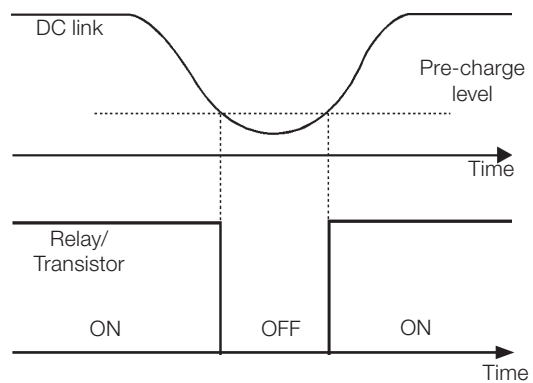

o) Process variable $Y < VP_y$

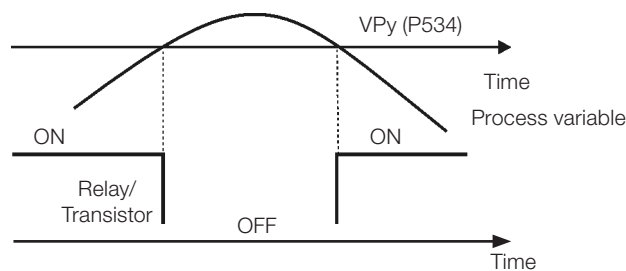

Figure 11.40: (a) to (o) Details on the operation of the digital output functions

Parameter	Range [Factory Setting] Unit	Description/Notes
P283 RL2 On Time	0.0 to 300.0 [0.0] 0.1 s	■ It is used with the output relay function: Relay 2 timer.
P284 RL2 Off Time	0.0 to 300.0 [0.0] 0.1 s	■ It is used with the output relay function: Relay 2 timer.
P285 RL3 On Time	0.0 to 300.0 [0.0] 0.1 s	■ It is used with the output relay function: Relay 3 timer.
P286 RL3 Off Time	0.0 to 300.0 [0.0] 0.1 s	■ It is used with the output relay function: Relay 3 timer.
P288 ⁽²⁾ Nx Speed	0 to P134 [120] 1 rpm	■ It is used with the output relay function: N* > Nx, N > Nx and N < Ny.
P289 ⁽²⁾ Ny Speed	0 to P134 [1800] 1 rpm	
P290 ⁽⁵⁾ Ix Current	0 to 2.0xP295 [1.0xP295] 0.1 A (<100) -1 A (>99.9)	■ It is used with the output relay function: Is > Ix and Is < Ix.
P291 Zero Speed Zone	1 to 100 [1] 1 %	■ It is used with the output relay function: N = 0 and Zero Speed Disable (Refer to P211 and P212 descriptions).
P292 N = N* Band (Reached Speed)	1 to 100 [1] 1 %	■ It is used with the output relay function: N = N*.
P293 Tx Torque	0 to 200 (P401) 100 (P401) %	■ Function not implemented in this software version.

P294
Overload Class

0 to 2
[0]
-

Table 11.45: Overload class

P294	Operation	Overload
0	Normal Overload Duty (ND)	115 % *
1	Heavy Overload Duty (HD)	150 % *
2	Maximum Current (MX)	100 % *

* For 60 s / 10 min

Parameter	Range [Factory Setting] Unit	Description/Notes					
P295 ⁽¹⁾ Inverter Rated Current	0 to 143 [According to the inverter rated current] A	<i>Table 11.46: Current available models</i>					
		P295	Rated Current G1	P295	Rated Current G2	P295	Rated Current G2
		0	32 A	70	54 A	122	627 A
		1	53 A	71	58 A	123	631 A
		2	70 A	72	67 A	124	664 A
		3	80 A	73	73 A	125	713 A
		4	85 A	74	78 A	126	740 A
		5	94 A	75	86 A	127	741 A
		6	100 A	76	91 A	128	779 A
		7	110 A	77	92 A	129	816 A
		8	112 A	78	96 A	130	835 A
		9	120 A	79	108 A	131	934 A
		10	130 A	80	109 A	132	941 A
		11	138 A	81	113 A	133	1069 A
		12	140 A	82	114 A	134	1087 A
		13	150 A	83	128 A	135	1234 A
		14	160 A	84	131 A	136	1254 A
		15	162 A	85	139 A	137	1425 A
		16	165 A	86	144 A	138	1482 A
		17	170 A	87	151 A	139	1632 A
		18	175 A	88	152 A	140	1881 A
		19	186 A	89	176 A	141	2138 A
		20	188 A	90	177 A	142	2508 A
		21	210 A	91	180 A	143	2850 A
		22	235 A	92	181 A		
		23	250 A	93	204 A		
		24	265 A	94	205 A		
		25	280 A	95	212 A		
		26	300 A	96	216 A		
		27	310 A	97	237 A		
		28	357 A	98	241 A		
		29	375 A	99	251 A		
		30	386 A	100	260 A		
		31	450 A	101	276 A		
		32	475 A	102	283 A		
		33	490 A	103	294 A		
		34	500 A	104	295 A		
		35	560 A	105	322 A		
		36	580 A	106	330 A		
		37	1064 A	107	332 A		
		38	712 A	108	348 A		
		39	880 A	109	376 A		
		40	950 A	110	390 A		
		41	1178 A	111	405 A		
		42	200 A	112	410 A		
		43	125 A	113	440 A		
		44	536 A	114	458 A		
		45	1072 A	115	481 A		
		46	1340 A	116	494 A		
		47	1424 A	117	517 A		
		48	1760 A	118	538 A		
		49	1900 A	119	561 A		
50	2356 A	120	565 A				
51	301 A	121	607 A				

Parameter	Range [Factory Setting] Unit	Description/Notes																
P296 ⁽¹⁾ Rated Voltage	0 to 6 [According to the inverter rated voltage] V	<p><i>Table 11.47: Voltage available models</i></p> <table border="1"> <thead> <tr> <th>P296</th> <th>Inverter Rated Voltage</th> </tr> </thead> <tbody> <tr> <td>0</td> <td>220 V *</td> </tr> <tr> <td>1</td> <td>380 V *</td> </tr> <tr> <td>2</td> <td>2300 V</td> </tr> <tr> <td>3</td> <td>3300 V</td> </tr> <tr> <td>4</td> <td>4160 V</td> </tr> <tr> <td>5</td> <td>6900 V</td> </tr> <tr> <td>6</td> <td>4600 V</td> </tr> </tbody> </table> <p>* Use of WEG.</p> <ul style="list-style-type: none"> For inverters of rated voltage of 6000 V, 6300 V and 6600 V, you must set P296 = 5. <div style="border: 1px solid black; padding: 5px;"> <p>ATTENTION! Adjust P296 according to the input AC voltage to be used!</p> </div>	P296	Inverter Rated Voltage	0	220 V *	1	380 V *	2	2300 V	3	3300 V	4	4160 V	5	6900 V	6	4600 V
P296	Inverter Rated Voltage																	
0	220 V *																	
1	380 V *																	
2	2300 V																	
3	3300 V																	
4	4160 V																	
5	6900 V																	
6	4600 V																	
P303 Skipped Speed 1 P304 Skipped Speed 2 P305 Skipped Speed 3 P306 Skipped Range	P133 to P134 [600] 1rpm P133 to P134 [900] 1rpm P133 to P134 [1200] 1rpm 0 to 750 [0] 1rpm	<p><i>Figure 11.41: Skipped speed curve</i></p> <ul style="list-style-type: none"> It avoids permanent motor operation at speeds in which, for instance, the mechanical system enters into resonance causing high vibration or noise levels. The passage through the skipped range ($2 \times P306$) occurs through the acceleration and deceleration ramps. The function does not operate properly if two bands of skipped speed overlap. 																
P308 ⁽¹⁾ Inverter Address	1 to 30 [1] -	<ul style="list-style-type: none"> It sets the inverter address for serial communication. Refer to the Section 13.2 WEGBUS SERIAL on page 13-12. 																

Parameter	Range [Factory Setting] Unit	Description/Notes																														
P309 ⁽¹⁾ Fieldbus	0 to 13 [0] -	<ul style="list-style-type: none"> ■ 0 = Inactive Fieldbus. ■ 1 to 6 = define the fieldbus standard to be used (Profibus DP or DeviceNet) and the number of variables to be exchanged with the master. Refer to the Item 13.1.6 Fieldbus Application/MVW-01 Related Parameters on page 13-7. ■ It is only applicable for the Profibus DP or DeviceNet optional kits. ■ For P309 = 10, refer to the DeviceNet Drive Profile guide. <p style="text-align: center;"><i>Table 11.48: Type of fieldbus protocol</i></p> <table border="1" data-bbox="683 611 1353 1066"> <thead> <tr> <th>P309</th> <th>Type</th> </tr> </thead> <tbody> <tr><td>0</td><td>Inactive</td></tr> <tr><td>1</td><td>Profibus-DP 2 I/O</td></tr> <tr><td>2</td><td>Profibus-DP 4 I/O</td></tr> <tr><td>3</td><td>Profibus-DP 6 I/O</td></tr> <tr><td>4</td><td>DeviceNet 2 I/O</td></tr> <tr><td>5</td><td>DeviceNet 4 I/O</td></tr> <tr><td>6</td><td>DeviceNet 6 I/O</td></tr> <tr><td>7</td><td>Modbus-RTU 2 I/O</td></tr> <tr><td>8</td><td>Modbus-RTU 4 I/O</td></tr> <tr><td>9</td><td>Modbus-RTU 6 I/O</td></tr> <tr><td>10</td><td>DeviceNet Drive Profile</td></tr> <tr><td>11</td><td>Ethernet/IP 2 I/O</td></tr> <tr><td>12</td><td>Ethernet/IP 4 I/O</td></tr> <tr><td>13</td><td>Ethernet/IP 6 I/O</td></tr> </tbody> </table>	P309	Type	0	Inactive	1	Profibus-DP 2 I/O	2	Profibus-DP 4 I/O	3	Profibus-DP 6 I/O	4	DeviceNet 2 I/O	5	DeviceNet 4 I/O	6	DeviceNet 6 I/O	7	Modbus-RTU 2 I/O	8	Modbus-RTU 4 I/O	9	Modbus-RTU 6 I/O	10	DeviceNet Drive Profile	11	Ethernet/IP 2 I/O	12	Ethernet/IP 4 I/O	13	Ethernet/IP 6 I/O
P309	Type																															
0	Inactive																															
1	Profibus-DP 2 I/O																															
2	Profibus-DP 4 I/O																															
3	Profibus-DP 6 I/O																															
4	DeviceNet 2 I/O																															
5	DeviceNet 4 I/O																															
6	DeviceNet 6 I/O																															
7	Modbus-RTU 2 I/O																															
8	Modbus-RTU 4 I/O																															
9	Modbus-RTU 6 I/O																															
10	DeviceNet Drive Profile																															
11	Ethernet/IP 2 I/O																															
12	Ethernet/IP 4 I/O																															
13	Ethernet/IP 6 I/O																															
P312 Type of Serial Protocol	0 to 11 [0] -	<p style="text-align: center;"><i>Table 11.49: Type of serial protocol</i></p> <table border="1" data-bbox="683 1160 1353 1554"> <thead> <tr> <th>P312</th> <th>Type</th> </tr> </thead> <tbody> <tr><td>0</td><td>WEG Protocol</td></tr> <tr><td>1</td><td>Modbus-RTU, 9600 bps, no parity</td></tr> <tr><td>2</td><td>Modbus-RTU, 9600 bps, odd parity</td></tr> <tr><td>3</td><td>Modbus-RTU, 9600 bps, even parity</td></tr> <tr><td>4</td><td>Modbus-RTU, 19200 bps, no parity</td></tr> <tr><td>5</td><td>Modbus-RTU, 19200 bps, odd parity</td></tr> <tr><td>6</td><td>Modbus-RTU, 19200 bps, even parity</td></tr> <tr><td>7</td><td>Modbus-RTU, 38400 bps, no parity</td></tr> <tr><td>8</td><td>Modbus-RTU, 38400 bps, odd parity</td></tr> <tr><td>9</td><td>Modbus-RTU, 38400 bps, even parity</td></tr> <tr><td>10</td><td>WEG Protocol, 19200 bps</td></tr> <tr><td>11</td><td>WEG Protocol, 38400 bps</td></tr> </tbody> </table> <ul style="list-style-type: none"> ■ It defines the type of protocol used for the serial communication. 	P312	Type	0	WEG Protocol	1	Modbus-RTU, 9600 bps, no parity	2	Modbus-RTU, 9600 bps, odd parity	3	Modbus-RTU, 9600 bps, even parity	4	Modbus-RTU, 19200 bps, no parity	5	Modbus-RTU, 19200 bps, odd parity	6	Modbus-RTU, 19200 bps, even parity	7	Modbus-RTU, 38400 bps, no parity	8	Modbus-RTU, 38400 bps, odd parity	9	Modbus-RTU, 38400 bps, even parity	10	WEG Protocol, 19200 bps	11	WEG Protocol, 38400 bps				
P312	Type																															
0	WEG Protocol																															
1	Modbus-RTU, 9600 bps, no parity																															
2	Modbus-RTU, 9600 bps, odd parity																															
3	Modbus-RTU, 9600 bps, even parity																															
4	Modbus-RTU, 19200 bps, no parity																															
5	Modbus-RTU, 19200 bps, odd parity																															
6	Modbus-RTU, 19200 bps, even parity																															
7	Modbus-RTU, 38400 bps, no parity																															
8	Modbus-RTU, 38400 bps, odd parity																															
9	Modbus-RTU, 38400 bps, even parity																															
10	WEG Protocol, 19200 bps																															
11	WEG Protocol, 38400 bps																															

Parameter	Range [Factory Setting] Unit	Description/Notes														
P313 Disabling with Alarm A128, A129 and A130	0 to 5 [0] -	<p><i>Table 11.50: Disabling with Alarm A128, A129 and A130</i></p> <table border="1"> <thead> <tr> <th>P313</th> <th>Function</th> </tr> </thead> <tbody> <tr> <td>0</td> <td>Disable via Run/Stop</td> </tr> <tr> <td>1</td> <td>Disable via General Enable</td> </tr> <tr> <td>2</td> <td>Inactive</td> </tr> <tr> <td>3</td> <td>Go to Local</td> </tr> <tr> <td>4</td> <td>Without Function</td> </tr> <tr> <td>5</td> <td>Fatal Failure</td> </tr> </tbody> </table> <ul style="list-style-type: none"> Defines the inverter behavior when the serial communication is inactive (causing A128), when the physical connection with the Fieldbus network master is interrupted (causing A129), when the Fieldbus board is inactive (causing A130) or when the communication between MVC3 and MVC4 boards is interrupted. 	P313	Function	0	Disable via Run/Stop	1	Disable via General Enable	2	Inactive	3	Go to Local	4	Without Function	5	Fatal Failure
P313	Function															
0	Disable via Run/Stop															
1	Disable via General Enable															
2	Inactive															
3	Go to Local															
4	Without Function															
5	Fatal Failure															
P314 Time for Serial Watchdog Action	0.0 to 999.0 [0.0] 0.1s	<p><i>Table 11.51: Time for serial watchdog action</i></p> <table border="1"> <thead> <tr> <th>P314</th> <th>Function</th> </tr> </thead> <tbody> <tr> <td>0.0</td> <td>Disabled</td> </tr> <tr> <td>0.1 to 999.0</td> <td>Enabled</td> </tr> </tbody> </table> <ul style="list-style-type: none"> If the inverter does not receive any valid serial telegram after the time programmed at P314 has elapsed, A128 will be indicated on the HMI and the inverter will execute the action programmed in P313 – Disabling with A128, A129 or A130. In order that the inverter be able to execute that action, it is necessary that the commands be programmed for the “Serial” option at the parameters P220 to P228. 	P314	Function	0.0	Disabled	0.1 to 999.0	Enabled								
P314	Function															
0.0	Disabled															
0.1 to 999.0	Enabled															
P315 Function of the MVC3 Control Board SCI1 Serial Channel	0 to 2 [0] -	<ul style="list-style-type: none"> It selects the function of the MVC3 control board SCI1 serial channel. <p><i>Table 11.52: Serial channel SCI1 function</i></p> <table border="1"> <thead> <tr> <th>P315</th> <th>Function</th> </tr> </thead> <tbody> <tr> <td>0</td> <td>Service HMI</td> </tr> <tr> <td>1</td> <td>Modbus serial for Tecsystem module</td> </tr> <tr> <td>2</td> <td>Modbus Serial for Pextron module</td> </tr> </tbody> </table>	P315	Function	0	Service HMI	1	Modbus serial for Tecsystem module	2	Modbus Serial for Pextron module						
P315	Function															
0	Service HMI															
1	Modbus serial for Tecsystem module															
2	Modbus Serial for Pextron module															
P320 ⁽¹⁾ Flying Start/ Ride-Through	0 to 3 [0] -	<p><i>Table 11.53: Flying Start/ Ride-Through</i></p> <table border="1"> <thead> <tr> <th>P320</th> <th>Function</th> </tr> </thead> <tbody> <tr> <td>0</td> <td>Inactive.</td> </tr> <tr> <td>1</td> <td>Only Flying Start is active [Valid only for P202 = 0, 1 or 2 (V/f Control)].</td> </tr> <tr> <td>2</td> <td>Flying Start and Ride-Through are active [Valid only for P202 = 0,1 or 2 (V/f Control)].</td> </tr> <tr> <td>3</td> <td>Only Ride-Through is active.</td> </tr> </tbody> </table> <div style="border: 1px solid black; padding: 5px; margin-top: 10px;"> <p> NOTE! With the Ride-Through function active, disable function 27 of the protection relay of the input.</p> </div>	P320	Function	0	Inactive.	1	Only Flying Start is active [Valid only for P202 = 0, 1 or 2 (V/f Control)].	2	Flying Start and Ride-Through are active [Valid only for P202 = 0,1 or 2 (V/f Control)].	3	Only Ride-Through is active.				
P320	Function															
0	Inactive.															
1	Only Flying Start is active [Valid only for P202 = 0, 1 or 2 (V/f Control)].															
2	Flying Start and Ride-Through are active [Valid only for P202 = 0,1 or 2 (V/f Control)].															
3	Only Ride-Through is active.															

The operation of these functions depends on the configuration of P331, P332, P333

Parameter	Range [Factory Setting] Unit	Description/Notes
P321 ⁽⁴⁾ Ud Line Loss Level This parameter is only visible on the display when P202 = 3 or 4 (Vector Control)	166 V to 800 V (P296 = 0) 252 V 1 V	<ul style="list-style-type: none"> ■ The occurrence of the Ride-Through function can be visualized at the outputs DO1, DO2, RL1, RL2 and/or RL3 (P275, P276, P277, P279 and/or P280) if they have been programmed as "23 = Ride-Through". ■ For inverters of rated voltage of 6000 V, 6300 V and 6600 V you must set P296 = 5; however for those values of rated voltage, P321 must be manually set to: 6000 V - 4038 V 6300 V - 4240 V 6600 V - 4442 V <div style="border: 1px solid black; padding: 5px; margin-top: 10px;"> NOTE! When either Ride-Through, is activated, the parameter P214 (Line Phase Loss Detection) is automatically set to 0 = Inactive. </div> <div style="border: 1px solid black; padding: 5px; margin-top: 10px;"> NOTE! Ud = Vac x 1.35. </div> <p><u>Ride-Through Vector Control (P202 = 3 or 4):</u></p> <ul style="list-style-type: none"> ■ The purpose of the Ride-Through function in vector mode (P202 = 3 or 4) is to assure that the inverter keeps the motor running without interruption or fault storage during a power failure. The energy necessary to maintain the inverter operation is obtained from the motor/load kinetic energy (inertia) through its controlled deceleration. After the recovery of the line, the motor accelerates again to the speed reference value.
	287 V to 800 V (P296 = 1) 436 V 1 V	
	2000 V to 8000 V (P296 = 2) 2681 V 1 V	
	2000 V to 8000 V (P296 = 3) 3847 V 1 V	
	2000 V to 8000 V (P296 = 4) 4850 V 1 V	
	2000 V to 8000 V (P296 = 5) 4644 V 1 V	
	2000 V to 8000 V (P296 = 6) 5363 V 1 V	

Parameter	Range [Factory Setting] Unit	Description/Notes
P322 ⁽⁴⁾ Ud Ride-Through This parameter is only visible on the display when P202 = 3 or 4 (Vector Control)	166 V to 800 V (P296 = 0) 245 V 1 V	<ul style="list-style-type: none"> After the line loss (t0), the DC Link voltage (Ud) starts decreasing according to a rate dependent on the motor load, it could reach the undervoltage level (t2) if the Ride-Through function were not active. With the Ride-Through function active, the line loss is detected when the Ud voltage drops below the value "Ud Line loss" (t1). Immediately the inverter keeps the input circuit breaker closed and it begins the controlled deceleration of motor, regenerating energy for the DC link so as to keep the motor running with the Ud voltage regulated at the "Ud Ride-Through" value. If the line does not return, the inverter remains in this condition as long as possible (depending on the inertia load) until undervoltage fault (F021) occurs at (t5). If the line returns (t3) before the undervoltage fault, the inverter detects it when the Ud voltage reaches the "Ud Recovery Level" (t4). Then the motor is accelerated, according to the adjusted ramp time, from the actual speed up to the active speed reference value (Figure 11.42 on page 11-77). If the line voltage falls in a region between P322 and P323 the values of P321, P322 and P323 must be readjusted. For inverters of rated voltage of 6000 V, 6300 V and 6600 V, you must set P296 = 5; however for those values of rated voltage, P322 must be manually set to: 6000 V - 3914 V 6300 V - 4190 V 6600 V - 4305 V
	287 V to 800 V (P296 = 1) 423 V 1 V	
	2000 V to 8000 V (P296 = 2) 2598 V 1 V	
	2000 V to 8000 V (P296 = 3) 3728 V 1 V	
	2000 V to 8000 V (P296 = 4) 4700 V 1 V	
	2000 V to 8000 V (P296 = 5) 4500 V 1 V	
	2000 V to 8000 V (P296 = 6) 5197 V 1 V	
P323 ⁽⁴⁾ Ud Line Recovery Level This parameter is only visible on the display when P202 = 3 or 4 (Vector Control)	166 V to 800 V (P296 = 0) 267 V 1 V	<div style="border: 1px solid black; padding: 5px; margin-bottom: 10px;"> NOTE! The Ride-Through function activation occurs when the power supply voltage is lower than the value (P321÷1.35). </div>
	287 V to 800 V (P296 = 1) 461 V 1 V	
	2000 V to 8000 V (P296 = 2) 2930 V 1 V	
	2000 V to 8000 V (P296 = 3) 4204 V 1 V	
	2000 V to 8000 V (P296 = 4) 5300 V 1 V	
	2000 V to 8000 V (P296 = 5) 5075 V 1 V	
	2000 V to 8000 V (P296 = 5) 5075 V 1 V	

NOTE!
 The Ride-Through function activation occurs when the power supply voltage is lower than the value (P321÷1.35).

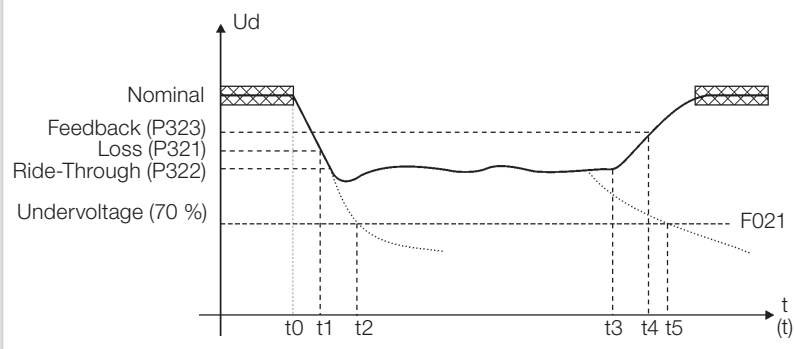

Figure 11.42: Actuation of the Ride-Through function in Vector Control mode

- t0 - line loss.
- t1 - line loss detection.
- t2 - Undervoltage fault trip (F021 without Ride-Through).
- t3 - line feedback.
- t4 - line feedback detection.
- t5 - Undervoltage fault trip (F021 with Ride-Through).
- For inverters of rated voltage of 6000 V, 6300 V and 6600 V, you must set P296 = 5; however for those values of rated voltage, P323 must be manually set to:

Parameter	Range [Factory Setting] Unit	Description/Notes						
	2000 V to 8000 V (P296 = 6) 5860 V 1 V	6000 V - 4413 V. 6300 V - 4634 V. 6600 V - 4855 V.						
<p>P325 Ride-Through Proportional Gain</p> <p>☑ This parameter is only visible on the display when P202 = 3 or 4 (Vector Control)</p> <p>P326 Ride-Through Integral Gain</p> <p>☑ This parameter is only visible on the display when P202 = 3 or 4 (Vector Control)</p>	<p>0.0 to 63.9 [1.0] 0.1</p> <p>0 to 9999 [201] 1</p>	<p>Figure 11.43: Ride-Through PI controller</p> <ul style="list-style-type: none"> The factory settings for P325 and P326 are adequate for the majority of the applications. Do not change these parameter settings. 						
<p>P327 Sensorless Flying Start Delay</p>	<p>0.000 to 9.999 0.100 0.001 s</p>	<ul style="list-style-type: none"> It is the delay to change the Sensorless Flying Start searching direction. 						
<p>P328 Sensorless Flying Start Frequency</p>	<p>0 = P134 1 = P001</p>	<p>Table 11.54: Flying Start frequency</p> <table border="1"> <thead> <tr> <th>P328</th> <th>Function</th> </tr> </thead> <tbody> <tr> <td>0</td> <td>P134 starting search speed</td> </tr> <tr> <td>1</td> <td>P001 starting search speed</td> </tr> </tbody> </table>	P328	Function	0	P134 starting search speed	1	P001 starting search speed
P328	Function							
0	P134 starting search speed							
1	P001 starting search speed							
<p>P329 Sensorless Flying Start Direction</p>	<p>0 = +P328 1 = -P328 2 = +P328 3 = -P328</p>	<ul style="list-style-type: none"> It is the Flying Start searching direction. 						

Parameter	Range [Factory Setting] Unit	Description/Notes
P331 Voltage Ramp	0.2 to 50.0 [8.0] 0.1 s	<p>Parameters are active with P202 = 0, 1 or 2 (V/F Control):</p> <ul style="list-style-type: none"> Parameter P331 sets the time required for the output voltage, starting from 0 V, to reach the nominal voltage. The Flying Start function allows starting a spinning motor. This function only acts when the inverter is enabled, then it imposes the speed of the reference and applies a voltage ramp with the time defined in P331. The parameter P332 sets the minimum time the inverter waits before restarting the motor after the line recovery in Ride-Through. This time is counted from the line voltage drop, and it is necessary for the motor de-magnetizing. P332 is also used in the start with Flying Start, before the beginning of the Flying Start. Set this time (P332) to twice the rotor constant of the motor The Ride-Through function allows the inverter recovery without F021 (DC link undervoltage), when a voltage dip occurs in the supply line. The inverter will indicate F003 (Input transformer secondary undervoltage fault) if the voltage dip lasts longer than P332 + P333 seconds. If Ride-Through is enabled and a voltage dip occurs, causing the DC link to drop below the undervoltage level, the output pulses are disabled and the motor coasts. If the line supply returns to its normal value, the inverter enables the pulses again, imposing the speed of the reference instantaneously and applying a voltage ramp with the time defined in P331. Refer to the Figure 11.44 on page 11-80. The Flying Start function does not work when P202 = 3 or 4. During the Ride-Through, the input circuit breaker is opened and the pre-charge relay is activated.
P332 Dead Time	0.1 to 20.0 [10.0] 0.1 s	
P333 Ride-Through Time	0.0 to 20.0 [10.0] 0.1 s	



The parameter P331 is only visible on the display if P202 = 0, 1 or 2 (V/F control)

Parameter	Range [Factory Setting] Unit	Description/Notes
		<p>(a) Line returns before the time set in P332</p>
		<p>(b) Line returns after the time set in P332, but before the time set P332 + P333</p>

Figure 11.44: (a) and (b) Actuation of the Ride-Through in V/F mode

11.4 MOTOR PARAMETERS - P400 TO P489

Parameter	Range [Factory Setting] Unit	Description/Notes
P400 ^{(1) (4)} Motor Rated Voltage	0 to 9999 [P296] 1 V	<ul style="list-style-type: none"> Set this parameter according to the motor nameplate data and the connection diagram used in the terminal box. In certain configurations, listed below, this parameter changes the inverter output voltage by applying a gain according to the relationship P400/P296 to the values defined by the V/f curves of the control mode chosen (P202) and of the torque boost set (P136 and P137) (see Figure 11.6 on page 11-21 to Figure 11.8 on page 11-21). This gain is added to the following configuration and control modes: <ul style="list-style-type: none"> - P202 = 0 with "sinusoidal output filter" option. - P202 = 1 with "sinusoidal output filter" option. - P202 = 2. The setting allowed for the relationship P400/P296 is represented in Figure 11.45 on page 11-81. There are only three operating regions: at 100 %, 79 % and 55 %, with variation of 5 %. For other requirements, contact WEG technical assistance. <div style="text-align: center;"> </div> <p><i>Figure 11.45: Recommended setting for P400/P296</i></p> <div style="border: 1px solid black; padding: 5px; margin-top: 10px;"> <p>NOTE! The motor output voltage (P400) must be lower than or equal to the inverter voltage (P296).</p> </div> <div style="border: 1px solid black; padding: 5px; margin-top: 10px;"> <p>NOTE! The change of P400 with the inverter enabled is only possible with P621 ≥ 1.</p> </div>
P401 ⁽¹⁾ Motor Rated Current	0.0 to 1.30xP295 [1.0xP295] 0.1 A(<100) 1 A(>99.9)	<ul style="list-style-type: none"> Adjust it according to the motor nameplate data, considering the motor operating voltage.
P402 ⁽¹⁾ Motor Rated Speed	0 to 7200 [1796] 1 rpm	<ul style="list-style-type: none"> Set this parameter according to the motor nameplate data. The range for V/F is from 0 to 7200 rpm.
P403 ⁽¹⁾ Motor Rated Frequency	0 to 120 [60] 1 Hz	<ul style="list-style-type: none"> Set this parameter according to the motor nameplate data. The range for V/F is from 0 to 120 Hz.

Parameter	Range [Factory Setting] Unit	Description/Notes						
P405 Encoder Data	100 to 9999 [1024] ppr	<ul style="list-style-type: none"> Program the number of pulses per revolution (PPR) of the used incremental encoder when P202 = 4 (Vector with Encoder). 						
P406 ^{(1) (2)} Motor Ventilation	0 or 1 [0] -	<p><i>Table 11.55: Type of motor ventilation</i></p> <table border="1"> <thead> <tr> <th>P406</th> <th>Motor Ventilation</th> </tr> </thead> <tbody> <tr> <td>0</td> <td>Self-ventilated</td> </tr> <tr> <td>1</td> <td>Separated ventilation</td> </tr> </tbody> </table> <ul style="list-style-type: none"> In the first power-up (refer to Chapter 8 INSTALLATION, CONNECTION AND ENERGIZATION on page 8-1) the value set in P406 automatically modifies the overload protection according to the description of parameters P156, P157 and P158. 	P406	Motor Ventilation	0	Self-ventilated	1	Separated ventilation
P406	Motor Ventilation							
0	Self-ventilated							
1	Separated ventilation							
P408 ⁽¹⁾ Self-Tuning	0 or 1 [0] -	<ul style="list-style-type: none"> With P408 = 1 (Autogain) the gains of the vector control regulators are automatically recalculated when the motor configuration parameters are changed. <p><i>Table 11.56: Self-Tuning</i></p> <table border="1"> <thead> <tr> <th>P408</th> <th>Function</th> </tr> </thead> <tbody> <tr> <td>0</td> <td>No autogain</td> </tr> <tr> <td>1</td> <td>Autogain</td> </tr> </tbody> </table>	P408	Function	0	No autogain	1	Autogain
P408	Function							
0	No autogain							
1	Autogain							
P409 ⁽¹⁾ Motor Stator Resistance (Rs)	0.000 to 9.999 [0.000] 0.001 Ω	<ul style="list-style-type: none"> It is the value of the motor stator resistance. 						
P410 Motor Magnetization Current (Imr)	0 to 1.25xP295 [0.0] 0.1 A	<ul style="list-style-type: none"> It is the value of the motor magnetization current. 						
P411 ⁽¹⁾ Motor Flux Leakage Inductance (ls)	0.00 to 99.99 [0.00] 0.01 mH	<ul style="list-style-type: none"> It is the value of the motor flux leakage inductance. 						
P412 ⁽¹⁾ Lr/Rr Constant (Rotor Time Constant-Tr)	0.000 to 9.999 [0.000] 0.001 s	<ul style="list-style-type: none"> Typical Tr values for standard WEG motors. 						
P413 ⁽¹⁾ TM Constant (Mechanical Time Constant)	0.00 to 99.99 [0.00] 0.01 s	<ul style="list-style-type: none"> It is the mechanical time constant of the driven load. 						

Parameter	Range [Factory Setting] Unit	Description/Notes
P414 Magnetizing Voltage This parameter is only visible when P202 = 0, 1 or 2 (V/F control)	0.0 to 20.0 [0.0] 0.1 %	<ul style="list-style-type: none"> It is a percentage of the nominal voltage applied during 2 x P412 to magnetize the motor when starting it.

11.5 PARAMETERS OF THE SYNCHRONOUS MOTOR - P427 TO P465

NOTE! Parameters of the Synchronous Motor only visible with P950 = 1 (Synchronous Motor).

Parameter	Range [Factory Setting] Unit	Description/Notes
P427 Inductance LD σ	0.00 to 99.99 [4.85] 1 mH	<ul style="list-style-type: none"> Motor parameter used on the stator flux observer. <div style="text-align: center;"> <p>Complete stator flux observer</p> <p>P427, P428, P429, P430, P431, P433, P434, P436 and P437</p> </div> <p><i>Figure 11.46: Complete model of the stator flow</i></p> <p><i>Figure 11.47: Electrical model of a synchronous motor</i></p>
P428 Inductance LQ σ	0.00 to 99.99 [4.41] 1 mH	<ul style="list-style-type: none"> Motor parameter used in stator flux model.

Parameter	Range [Factory Setting] Unit	Description/Notes
P429 Resistance RD	0.000 to 9.999 [1.139] 1 Ω	■ Motor parameter used in the stator flux model.
P430 Resistance RQ	0.000 to 9.999 [0.831] 1 Ω	■ Motor parameter used in the stator flux model.
P431 Number of Motor Poles	2 to 64 [4] -	■ Number of poles of the motor, which can be determined by: Number of poles = $\frac{120 \times \text{frequency}_{\text{rated}}}{\text{rpm}_{\text{rated}}}$
P433 Inductance LQ	000.0 to 999.9 [45.7] 1 mH	■ Stator LQ inductance of the synchronous motor.
P434 Inductance LD	000.0 to 999.9 [86.9] 1 mH	■ Stator LD inductance of the synchronous motor.
P436 Inductance LF	000.0 to 999.9 [88] 1 mH	■ LF field inductance of the synchronous motor.
P437 Resistance RF	0.000 to 9.999 [0.047] 1 Ω	■ Field resistance of the synchronous motor.
P438 Proportional Gain of the Current Regulator IQ	0.000 to 9.999 [0.034] -	■ Parameter used by the regulator to control the currents. <div style="text-align: center; margin-top: 10px;"> </div>
P439 Integration Constant of the Current Regulator IQ	0.1 to 999.9 [9.0] -	■ Parameter used by the regulator to control the currents.
P440 Proportional Gain of the Current Regulator ID	0.1 to 9.999 [0.074] -	■ Parameter used by the regulator to control the currents.

Figure 11.48: Diagram of the regulator of current and parameters used in the calculation of this

Parameter	Range [Factory Setting] Unit	Description/Notes
P441 Integration Constant of the ID Current Regulator	0.1 to 999.9 [19.6] -	<ul style="list-style-type: none"> Parameter used by the regulator to control the currents.
P442 Proportional Gain of the Field Current Regulator	0.000 to 9.999 [0.788] -	<ul style="list-style-type: none"> Function not implemented in this software version.
P443 Integration Constant of the Field Current Regulator	0.1 to 999.9 [703] -	<ul style="list-style-type: none"> Function not implemented in this software version.
P444 Maximum Field Voltage (Brushless)	0.01 to 1.00 [0.58] PU	<ul style="list-style-type: none"> Function not implemented in this software version.
P445 Minimum Field Voltage (Brushless)	0.01 to 1.00 [0.01] PU	<ul style="list-style-type: none"> Function not implemented in this software version.
P446 Base Field Current	0.1 to 999.9 [33.3] 1 A	<ul style="list-style-type: none"> Current base used for the field current.
P447 Proportional Gain of the Field Regulator	0.000 to 9.999 [0.087] -	<ul style="list-style-type: none"> PI (integrator proportional) gain used in the reference of the field regulator.
P448 Integration Constant of the Field Regulator	1 to 9999 [70] -	<ul style="list-style-type: none"> PI (integrator proportional) gain used in the reference of the field regulator.
P449 Maximum Field Current (Brushless)	0.01 to 5.00 [0.7] PU	<ul style="list-style-type: none"> Maximum limit in PU of P462 used in the control of the field current reference; see Section 7.2 FIELD EXCITATION SET (DC WITH BRUSHES) on page 7-3. Set according to the possible overload on the inverter/exciter.
P450 Minimum Field Current (Brushless)	0.01 to 5.00 [0.01] PU	<ul style="list-style-type: none"> Minimum limit in PU of P462 used in the control of the field current reference; see Section 7.2 FIELD EXCITATION SET (DC WITH BRUSHES) on page 7-3. Minimum field for frequency higher than P452.

Parameter	Range [Factory Setting] Unit	Description/Notes
P451 Minimum Field for Soft-Start Function	0.01 to 5.00 [0.15] PU	<ul style="list-style-type: none"> ■ Minimum field in PU of P462 used in the control of the field current reference (see Section 7.2 FIELD EXCITATION SET (DC WITH BRUSHES) on page 7-3). ■ Minimum field for frequency lower than or equal to P452. ■ Used in the soft-start function without rotor orientation in scalar mode. <div style="border: 1px solid black; padding: 5px; margin-top: 10px;"> NOTE! Function used in motor without encoder. </div>
P452 Field Input Frequency	0.00 to 10.00 [0] Hz	<ul style="list-style-type: none"> ■ Input frequency of the field excitation in scalar mode used in the soft-start function without rotor orientation. <div style="border: 1px solid black; padding: 5px; margin-top: 10px;"> NOTE! In scalar mode without encoder, the motor must “match” the inverter, and it is not possible the start of motors of currents higher than the inverter current. </div> <div style="border: 1px solid black; padding: 5px; margin-top: 10px;"> NOTE! When encoder is used, this parameter must be set to 0 Hz, disabling the soft-start without encoder function. </div> <div style="border: 1px solid black; padding: 5px; margin-top: 10px;"> ATTENTION! For encoder setting: - Set parameter P452 (field input frequency) equal to 0 Hz. - The control type (P202) must be scalar and the direction of rotation forward; configure one of the analog outputs for the encoder setting (E.g.: P656 = [018] EncAdjMS). </div> <div style="border: 1px solid black; padding: 5px; margin-top: 10px;"> NOTE! For further information, contact WEG Technical Assistance. </div>
P453 Field Ramp Time	0.00 to 30.00 [1] 0.01 s	<ul style="list-style-type: none"> ■ Field ramp time in seconds, used in the field regulator reference. ■ Used in the field soft-start.

Parameter	Range [Factory Setting] Unit	Description/Notes
P454 Polynomial A1 of the Magnetic Saturation Curve	0.000 to 9.999 [0.000] -	<ul style="list-style-type: none"> ■ Coefficient of the polynomial of the magnetic saturation curve. ■ The machine operates with linear flux up to the point in which the linear curve follows the saturation curve; from this point the machine flux follows a mathematical model obtained from the data of the motor manufacturer. <div style="text-align: center;"> </div> <p>Figure 11.49: Typical saturation curve and mathematical approximations used by the inverter for flux control</p> <div style="border: 1px solid black; padding: 5px; margin-top: 10px;"> <p>NOTE! For further information, contact WEG Technical Assistance.</p> </div>
P455 Polynomial B1 of the Magnetic Saturation Curve	0.000 to 9.999 [0.174] -	<ul style="list-style-type: none"> ■ Coefficient of the polynomial of the magnetic saturation curve.
P456 Polynomial C1 of the Magnetic Saturation Curve	0.000 to 9.999 [1.059] -	<ul style="list-style-type: none"> ■ Coefficient of the polynomial of the magnetic saturation curve.
P457 Polynomial A2 of the Gain Curve of the Brushless Exciter	0.000 to 9.999 [0.185] -	<ul style="list-style-type: none"> ■ Function not implemented in this software version.
P458 Polynomial B2 of the Gain Curve of the Brushless Exciter	0.000 to 9.999 [0.068] -	<ul style="list-style-type: none"> ■ Function not implemented in this software version.

Parameter	Range [Factory Setting] Unit	Description/Notes
P459 Polynomial C2 of the Gain Curve of the Brushless Exciter	0.0 to 999.9 [118.7] -	<ul style="list-style-type: none"> Function not implemented in this software version.
P460 Field Resistance Not Referred to the Stator	0.001 to 9.999 [1.150] 0.001 Ω	<ul style="list-style-type: none"> Function not implemented in this software version.
P461 Rated Current on the Brushless Field	0.1 to 999.9 [25.6] 0.1 A	<ul style="list-style-type: none"> Function not implemented in this software version.
P462 Field Current Scale	0.1 to 999.9 [94] 0.1 A	<ul style="list-style-type: none"> Parameter used in the control of the field current with exciter with brushes. Function not implemented in this software version.
P463 Exciter Rated Voltage Scale	0 to 9999 [380] 1 V	<ul style="list-style-type: none"> Parameter used in the control of the field current with exciter with brushes. Function not implemented in this software version.
P464 Maximum Compensation Current of the Power Factor	0.00 to 1.00 [0.80] 0.01 PU	<ul style="list-style-type: none"> Maximum compensation current, in PU, of the power factor. <div style="text-align: center;"> <p>Power factor control</p> </div>

Figure 11.50: Block diagram of the power factor control

Parameter	Range [Factory Setting] Unit
P465 Field Delay	0.000 to 9.999 [0.00] 0.001 s

- Delay in seconds applied to the field used in the speed control of the synchronous machine.

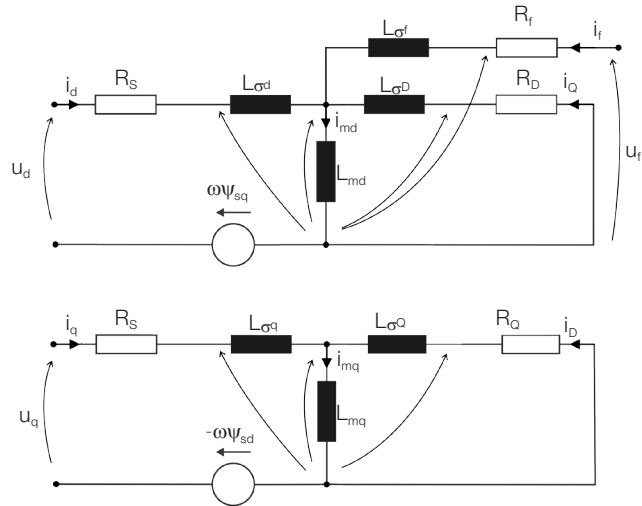

Figure 11.51: Electrical model of a synchronous motor

Table 11.57: Motor output parameters

Parameter	Unit	Description
P427	mH	Inductance LDσ
P428	mH	InductanceLQσ
P429	Ω	Resistance RD
P430	Ω	Resistance RQ
P431		Number Poles of the Motor
P433	mH	Inductance LQ
P434	mH	Inductance LD
P436	mH	Inductance LF
P437	Ω	Resistance RF



NOTE!

To determine P427...P437, contact WEG Technical Assistance

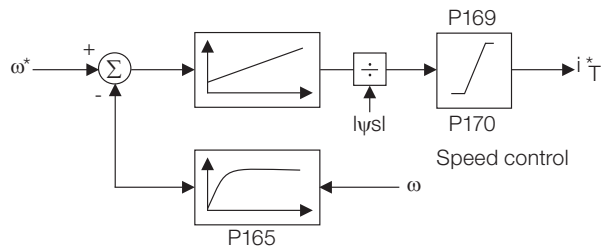

Figure 11.52: Block diagram of the speed control

11.6 PARAMETER OF THE GRAPHIC HMI - P490 TO P519

Parameter	Range [Factory Setting] Unit	Description / Notes																						
P490 Graphic HMI LCD Contrast Adjustment	0 to 150 [80] %	<ul style="list-style-type: none"> It adjusts the Graphic LCD contrast percentage. 																						
P491 Graphic HMI Configuration	0 to 2 [0] -	<ul style="list-style-type: none"> It configures the origin of the inverter Local or Remote (LOC/ REM) commands for the 'Serial' type, so that the Graphic HMI be able to operate in an adequate manner (the Graphic HMI commands are of the Modbus RTU serial type). <p style="text-align: center;"><i>Table 11.58: Graphic HMI commands selection</i></p> <table border="1" style="margin-left: auto; margin-right: auto;"> <thead> <tr> <th>P491</th> <th>Function</th> </tr> </thead> <tbody> <tr> <td>0</td> <td>Inactive</td> </tr> <tr> <td>1</td> <td>Local HMIG</td> </tr> <tr> <td>2</td> <td>Remote HMIG</td> </tr> </tbody> </table>	P491	Function	0	Inactive	1	Local HMIG	2	Remote HMIG														
P491	Function																							
0	Inactive																							
1	Local HMIG																							
2	Remote HMIG																							
P493 Sampling Time of the On-line Graphic Function	1 to 100 [10] 1 x 10 ms	<ul style="list-style-type: none"> It adjusts the time between the points presented in the On-line Graphic Function. 																						
P500 Read-only Parameter #1 Selection	0 to 9 [0] 2	<ul style="list-style-type: none"> It selects one of the monitoring parameters. From 1 to 6 read-only parameters can be programmed for simultaneous exhibition among the 9 available ones. <p style="text-align: center;"><i>Table 11.59: Read-only parameters selection</i></p> <table border="1" style="margin-left: auto; margin-right: auto;"> <thead> <tr> <th>P500...P505</th> <th>Read-only Parameter</th> </tr> </thead> <tbody> <tr> <td>0</td> <td>Inactive</td> </tr> <tr> <td>1</td> <td>P001</td> </tr> <tr> <td>2</td> <td>P002</td> </tr> <tr> <td>3</td> <td>P003</td> </tr> <tr> <td>4</td> <td>P004</td> </tr> <tr> <td>5</td> <td>P005</td> </tr> <tr> <td>6</td> <td>P007</td> </tr> <tr> <td>7</td> <td>P009</td> </tr> <tr> <td>8</td> <td>P010</td> </tr> <tr> <td>9</td> <td>P040</td> </tr> </tbody> </table>	P500...P505	Read-only Parameter	0	Inactive	1	P001	2	P002	3	P003	4	P004	5	P005	6	P007	7	P009	8	P010	9	P040
P500...P505	Read-only Parameter																							
0	Inactive																							
1	P001																							
2	P002																							
3	P003																							
4	P004																							
5	P005																							
6	P007																							
7	P009																							
8	P010																							
9	P040																							
P501 Read-only Parameter #2 Selection	0 to 9 [0] 0																							
P502 Read-only Parameter #3 Selection	0 to 9 [0] 0																							
P503 Read-only Parameter #4 Selection	0 to 9 [0] 0																							
P504 Read-only Parameter #5 Selection	0 to 9 [0] 0																							
P505 Read-only Parameter #6 Selection	0 to 9 [0] 0																							

Parameter	Range [Factory Setting] Unit	Description / Notes																						
<p>P512 On-line Graphic Function Parameter #1 Selection</p> <p>P513 On-line Graphic Function Parameter #2 Selection</p>	<p>0 to 9 [0] 2</p> <p>0 to 9 [0] 3</p>	<ul style="list-style-type: none"> It selects one of the parameters to be monitored by the On-line Graphic Function (Watch Function). <p>Table 11.60: On-line graphic function parameters selection</p> <table border="1"> <thead> <tr> <th>P512...P513</th> <th>Read-only Parameter</th> </tr> </thead> <tbody> <tr><td>0</td><td>Inactive</td></tr> <tr><td>1</td><td>P001</td></tr> <tr><td>2</td><td>P002</td></tr> <tr><td>3</td><td>P003</td></tr> <tr><td>4</td><td>P004</td></tr> <tr><td>5</td><td>P005</td></tr> <tr><td>6</td><td>P007</td></tr> <tr><td>7</td><td>P009</td></tr> <tr><td>8</td><td>P010</td></tr> <tr><td>9</td><td>P040</td></tr> </tbody> </table>	P512...P513	Read-only Parameter	0	Inactive	1	P001	2	P002	3	P003	4	P004	5	P005	6	P007	7	P009	8	P010	9	P040
P512...P513	Read-only Parameter																							
0	Inactive																							
1	P001																							
2	P002																							
3	P003																							
4	P004																							
5	P005																							
6	P007																							
7	P009																							
8	P010																							
9	P040																							
<p>P516 Full Scale of the On-line Graphic Function Parameter #1</p> <p>P517 Full Scale of the On-line Graphic Function Parameter #2</p>	<p>0 to 200 [100] %</p> <p>0 to 200 [100] %</p>	<ul style="list-style-type: none"> It adjusts the full scale of the on-line graphic correspondent parameter. <p>Table 11.61: Adjust of the full scale of the on-line graphic function</p> <table border="1"> <thead> <tr> <th>P516...P517</th> <th>Full Scale</th> </tr> </thead> <tbody> <tr><td>P001</td><td>P208</td></tr> <tr><td>P002</td><td>P208</td></tr> <tr><td>P003</td><td>P295</td></tr> <tr><td>P004</td><td>1.35 x P296</td></tr> <tr><td>P005</td><td>P403</td></tr> <tr><td>P007</td><td>P296</td></tr> <tr><td>P009</td><td>(P295 / P401) x 100 %</td></tr> <tr><td>P010</td><td>1.732 x (P295 x P296)</td></tr> <tr><td>P040</td><td>100 %</td></tr> </tbody> </table>	P516...P517	Full Scale	P001	P208	P002	P208	P003	P295	P004	1.35 x P296	P005	P403	P007	P296	P009	(P295 / P401) x 100 %	P010	1.732 x (P295 x P296)	P040	100 %		
P516...P517	Full Scale																							
P001	P208																							
P002	P208																							
P003	P295																							
P004	1.35 x P296																							
P005	P403																							
P007	P296																							
P009	(P295 / P401) x 100 %																							
P010	1.732 x (P295 x P296)																							
P040	100 %																							

11.7 PARAMETERS OF THE PID FUNCTION - P520 TO P535

Parameter	Range [Factory Setting] Unit	Description/Notes																																													
P520 PID Proportional Gain	0.000 to 7.999 [1.000] 0.001	<ul style="list-style-type: none"> The initial gain and PID ramp settings recommendation for some applications mentioned in the Section 12.2 PID Regulator on page 12-6, are given in the Table 11.62 on page 11-92. <p style="text-align: center;"><i>Table 11.62: PID initial gain setting suggestions</i></p> <table border="1"> <thead> <tr> <th rowspan="2">Process variable</th> <th colspan="3">Gains</th> <th rowspan="2">P523 PID Ramp</th> <th rowspan="2">P527 Action type</th> </tr> <tr> <th>Proportional P520</th> <th>Integral P521</th> <th>Proportional P522</th> </tr> </thead> <tbody> <tr> <td>Pneumatic system pressure</td> <td>1</td> <td>0.043</td> <td>0.000</td> <td>3</td> <td>0 = Direct</td> </tr> <tr> <td>Pneumatic system flow</td> <td>1</td> <td>0.037</td> <td>0.000</td> <td>3</td> <td>0 = Direta</td> </tr> <tr> <td>Hydraulic system pressure</td> <td>1</td> <td>0.043</td> <td>0.000</td> <td>3</td> <td>0 = Direct</td> </tr> <tr> <td>Hydraulic system flow</td> <td>1</td> <td>0.037</td> <td>0.000</td> <td>3</td> <td>0 = Direct</td> </tr> <tr> <td>Temperature</td> <td>2</td> <td>0.004</td> <td>0.000</td> <td>3</td> <td>Notes</td> </tr> <tr> <td>Level</td> <td>1</td> <td>Notes</td> <td>0.000</td> <td>3</td> <td>Notes</td> </tr> </tbody> </table> <p>Notes:</p> <ul style="list-style-type: none"> For temperature and level, the action type setting will depend on the process. For level control, for instance, if the inverter drives the motor that pumps fluid out of the reservoir, the action will be reverse because when the level increases the inverter must increase the motor speed in order to lower the level, otherwise, when the inverter drives a motor that pumps fluid into the reservoir, the action will be direct.. In case of level control, the integral gain adjustment will depend on the time required for the reservoir to pass from the minimum acceptable to the desired level, in the following conditions: <ol style="list-style-type: none"> For direct action, the time must be measured with maximum input flow and minimum output flow. For reverse action, the time must be measured with minimum input flow and maximum output flow. <p>An equation to calculate an initial value for P521 (PID Integral Gain) as a function of the system response time, is presented below:</p> $P521 = 0.02 / t$ <p style="text-align: center;">t = time (seconds)</p>	Process variable	Gains			P523 PID Ramp	P527 Action type	Proportional P520	Integral P521	Proportional P522	Pneumatic system pressure	1	0.043	0.000	3	0 = Direct	Pneumatic system flow	1	0.037	0.000	3	0 = Direta	Hydraulic system pressure	1	0.043	0.000	3	0 = Direct	Hydraulic system flow	1	0.037	0.000	3	0 = Direct	Temperature	2	0.004	0.000	3	Notes	Level	1	Notes	0.000	3	Notes
Process variable	Gains			P523 PID Ramp	P527 Action type																																										
	Proportional P520		Integral P521			Proportional P522																																									
Pneumatic system pressure	1		0.043	0.000	3	0 = Direct																																									
Pneumatic system flow	1		0.037	0.000	3	0 = Direta																																									
Hydraulic system pressure	1	0.043	0.000	3	0 = Direct																																										
Hydraulic system flow	1	0.037	0.000	3	0 = Direct																																										
Temperature	2	0.004	0.000	3	Notes																																										
Level	1	Notes	0.000	3	Notes																																										
P521 PID Integral Gain	0.000 to 9.999 [1.000] 0.001 (<9.999) 0.01 (>9.999)																																														
P522 PID Differential Gain	0.000 to 9.999 [0.000] 0.001																																														
P523 PID Ramp Time	0.0 to 999.0 [3.0] 0.1s (<99.9s) 1s (>99.9s)																																														

These parameters are only visible on the display if P203 = 1 or 3

Parameter	Range [Factory Setting] Unit	Description/Notes						
<p>P524 ⁽¹⁾ PID Feedback Selection</p> <p> This parameter is only visible on the display if P203 = 1 or 3</p>	<p>0 or 1 [0] -</p>	<ul style="list-style-type: none"> It defines the PID regulator feedback (Process variable) input. <p style="text-align: center;"><i>Table 11.63: Feedback input selection</i></p> <table border="1" data-bbox="847 421 1342 510"> <thead> <tr> <th>P524</th> <th>AIx</th> </tr> </thead> <tbody> <tr> <td>0</td> <td>AI2 (P237 to P240 and P248)</td> </tr> <tr> <td>1</td> <td>AI3 (P241 to P244)</td> </tr> </tbody> </table> <ul style="list-style-type: none"> After the feedback input has been chosen, the function of the selected input must be programmed at P237 (for AI2) or at P241 (for AI3). Feedback type: <ul style="list-style-type: none"> The PID action type described above considers that the process variable feedback signal increases when the process variable also increases (direct feedback). This is the most used feedback type. If the process variable feedback decreases as the process variable increases (inverse feedback), then it is necessary to program the selected PID feedback analog input as inverse reference: For AI2 feedback, P239 = 2 (10 to 0 V/20 to 0 mA) or P239 = 3 (20 to 4 mA). For AI3 feedback, P243 = 2 (10 to 0 V/20 to 0 mA) or P243 = 3 (20 to 4 mA). Without this setting, the PID does not operate correctly. 	P524	AIx	0	AI2 (P237 to P240 and P248)	1	AI3 (P241 to P244)
P524	AIx							
0	AI2 (P237 to P240 and P248)							
1	AI3 (P241 to P244)							
<p>P525 Keypad PID Setpoint</p> <p> and </p> <p> This parameter is only visible on the display if P203 = 1 or 3</p>	<p>0.0 to 100.0 [0.0] 0.1 %</p>	<ul style="list-style-type: none"> It provides the PID regulator setpoint that is adjusted via the and keys provided that P221 = 0 (Local) or P222 = 0 (Remote), and in automatic mode. If the PID is in manual mode, then the speed reference is given by P121. When the PID regulator is operating in automatic mode, the setpoint is the one defined as speed reference via P221 (Local) or P222 (Remote). The majority of PID applications either use setpoint via analog input AI1 (P221 = 1 in Local, or P222 = 1 in Remote), or via and keys (P221 = 0 in Local, or P222 = 0 in Remote). Refer to the Figure 12.6 on page 12-8. 						
<p>P526 Process Variable Filter</p> <p> This parameter is only visible on the display if P203 = 1 or 3</p>	<p>0.0 to 16.0 [0.1] 0.1 s</p>	<ul style="list-style-type: none"> It adjusts the process variable filter time constant. The 0.1 s value is usually adequate, unless the process variable presents much noise. In such case, increase the value gradually, observing the result. 						

Parameter	Range [Factory Setting] Unit	Description/Notes														
<p>P527 PID Action Type</p> <p> This parameter is only visible on the display if P203 = 1 or 3</p>	<p>0 or 1 [0] -</p>	<ul style="list-style-type: none"> It defines the type of PID control action: <p style="text-align: center;"><i>Table 11.64: PID action type</i></p> <table border="1" data-bbox="770 421 1265 512"> <thead> <tr> <th>P527</th> <th>Action type</th> </tr> </thead> <tbody> <tr> <td>0</td> <td>Direct</td> </tr> <tr> <td>1</td> <td>Reverse</td> </tr> </tbody> </table> Selection criteria: <p style="text-align: center;"><i>Table 11.65: Selection of operation</i></p> <table border="1" data-bbox="745 658 1292 779"> <thead> <tr> <th>Motor speed</th> <th>Process variable</th> <th>Action type</th> </tr> </thead> <tbody> <tr> <td rowspan="2">Increases</td> <td>Increases</td> <td>Direct</td> </tr> <tr> <td>Decreases</td> <td>Reverse</td> </tr> </tbody> </table> Selection according to the process requirements: <ul style="list-style-type: none"> - PID action type: the action must be selected as Direct when it is necessary to increase the motor speed to increase the process variable. Otherwise, select Reverse. <p>Example 1 – Direct: the inverter drives a pump responsible for filling a water reservoir using the PID to control the level. In order that the level (process variable) increases, it is necessary that the flow, and consequently the motor speed, also increases.</p> <p>Example 2 – Reverse: The inverter drives a fan responsible for refrigerating a cooling tower using the PID to control the temperature. In order to increase the temperature (process variable), it is necessary to decrease the ventilation by decreasing the motor speed.</p> 	P527	Action type	0	Direct	1	Reverse	Motor speed	Process variable	Action type	Increases	Increases	Direct	Decreases	Reverse
P527	Action type															
0	Direct															
1	Reverse															
Motor speed	Process variable	Action type														
Increases	Increases	Direct														
	Decreases	Reverse														

Parameter	Range [Factory Setting] Unit	Description/Notes
P528 Process Variable Scale Factor	0 to 9999 [1000] -	<ul style="list-style-type: none"> ■ P528 and P529 define how the process variable (P040) will be displayed. ■ P529 defines the number of digits after the decimal point. ■ P528 must be adjusted according to the equation below:
P529 Process Variable Decimal Point	0 to 3 [1] -	$P528 = \frac{\text{Process F.S.V. indication} \times (10)^{P529}}{\text{Gain (AI2 or AI3)}}$
 These parameters are only visible on the display if P203 = 1 or 3		<p>Where: Process F.S.V. indication = Process variable full-scale value, corresponding to 10 V or 20 mA at the feedback analog input (AI2 or AI3).</p> <p>Example 1 (0 to 25 bar pressure transducer with 4 to 20 mA) output signal:</p> <ul style="list-style-type: none"> - Desired indication: 0 to 25 bar (Process F.S.V). - Feedback input: AI3. - AI3 gain = P242 = 1.000. - AI3 signal = P243 = 1 (4 to 20 mA). - P529 = 0 (no positions after the decimal point). $P528 = \frac{25 \times (10)^0}{1.000} = 25$ <p>Example 2 Factory default values:</p> <ul style="list-style-type: none"> - Desired indication: 0.0 % to 100 % (Process F.S.V). - Feedback input: AI2. - AI2 gain = P238 = 1.000. - P529 = 1 (one position after the decimal point). $P528 = \frac{100.0 \times (10)^1}{1.000} = 1000$

Parameter	Range [Factory Setting] Unit	Description/Notes
P530 Process Variable Engineering Unit 1	32 to 127 [37 (%)] -	<ul style="list-style-type: none"> These parameters are useful only for inverters fitted with an LCD keypad. The process variable engineering unit is formed by three characters, which will be applied to the parameter P040 indication. P530 defines the leftmost character, P531 the center one and P532 the rightmost. Characters that can be chosen: Characters corresponding to ASCII code from 32 to 127. Examples: A, B, ... , Y, Z, a, b, ... , y, z, 0, 1, ... , 9, #, \$, %, (,), *, +, ... <p>Examples:</p> <ul style="list-style-type: none"> To indicate "bar": P530 = "b" (98) P531 = "a" (97) P532 = "r" (114) To indicate "%": P530 = "%" (37) P531 = " " (32) P532 = " " (32) <div style="border: 1px solid black; padding: 5px; margin-top: 10px;"> <p> NOTE! The configuration of the engineering unit is only valid for the service HMI.</p> </div>
P531 Process Variable Engineering Unit 2	32 to 127 [32 ()] -	
P532 Process Variable Engineering Unit 3	32 to 127 [32 ()] -	
<p> These parameters are only visible on the display if P203 = 1 or 3</p>		
P533 VPx Value	0.0 to 100.0 [90.0] 0.1 %	<ul style="list-style-type: none"> They are used with the digital and relay output functions: V. Pr. > VPx and V. Pr. < VPy with the function of signal/alarm. The process variable full scale value in percentage is: $(P040 = \frac{(10)^{P529}}{P528} \times 100 \%)$ <ul style="list-style-type: none"> P535 works together with P212 (Condition to Leave Zero Speed Disable), giving an additional condition to leave the disabled condition, i.e., PID error > P535. Refer to P211 and P213 descriptions.
P534 VPy Value	0.0 to 100.0 [10.0] 0.1 %	
P535 Output N = 0 PID	0 to 100 [0] 1 %	
<p> These parameters are only visible on the display if P203 = 1 or 3</p>		

11.8 PARAMETERS OF THE TRACE FUNCTION

Parameter	Range [Factory Setting] Unit	Description/Notes
P550 Trigger Parameter	0 to 746 [0] -	<ul style="list-style-type: none"> Program the number of the parameter to be used as trigger for the Trace function. Example: By programming P550 = 4 the trigger parameter will be P004 (DC Link Voltage). Note: When the trigger is defined by alarm or fault, then P550 can have any value. Refer to the P552 description.

Parameter	Range [Factory Setting] Unit	Description/Notes
P551 Trigger Value	-32768 to +32767 [0] -	<ul style="list-style-type: none"> The value programmed in P551 is compared to the contents of the parameter defined at P550. If the trigger condition is fulfilled, (refer to P552), the Trace function will be triggered. The user must apply the processor internal representation, so that the Trace function works properly. Example: If P550 = 100, set P551 = 100 in case the user wishes to compare P100 (acceleration ramp) with a setting of 10.0 seconds for the trigger.

P552 Trigger Condition	0 to 20 [4] -	<ul style="list-style-type: none"> Refer to P550. With the factory default programming (refer to the Trace function programming example, Figure 12.1 on page 12-1) the trigger is defined as a fault trip. Trigger condition of the trace function, according to the table below.
----------------------------------	-----------------------	--

Table 11.66: Trace function trigger condition

P552	Trigger Condition		
0	P550* = P551		
1	P550* ≠ P551		
2	P550* > P551		
3	P550* < P551		
4	Inverter in state fault		
-	Binary Selection (bit mask)	Respective DI (P550 = 12)	Respective DO (P550 = 13)
5	P550* bit 0 = P551	DI8	-
6	P550* bit 1 = P551	DI7	RL5
7	P550* bit 2 = P551	DI6	RL4
8	P550* bit 3 = P551	DI5	RL3
9	P550* bit 4 = P551	DI4	RL2
10	P550* bit 5 = P551	DI3	RL1
11	P550* bit 6 = P551	DI2	DO2
12	P550* bit 7 = P551	DI1	DO1
13	P550* bit 8 = P551	DI9	-
14	P550* bit 9 = P551	DI10	-
15	P550* bit 10 = P551	-	-
16	P550* bit 11 = P551	-	-
17	P550* bit 12 = P551	-	-
18	P550* bit 13 = P551	-	-
19	P550* bit 14 = P551	-	-
20	P550* bit 15 = P551	-	-

* Contents of the parameter programmed at P550.

Note: the binary selection conditions (5 to 20) are only effective if the parameter programmed in P550 is 12 or 13 (P012 or P013).

Parameter	Range [Factory Setting] Unit	Description/Notes																											
P553 Sampling Time	1 to 9999 [1] x500 µs	<ul style="list-style-type: none"> It is the trace channels sampling time (as a multiplier of the 500 µs time base). Example: If P553 = 10 (10 x 500 µs), a sampling time of 5 ms is obtained. 																											
P554 Pre-Trigger Percentage	0 to 100 [50] 1 %	<ul style="list-style-type: none"> It is the percentage of trace data before the trigger event that has to be recorded. 																											
P555 CH1 - Trace channel 1 P557 CH2 - Trace channel 2 P559 CH3 - Trace channel 3 P561 CH4 - Trace channel 4 P563 CH5 - Trace channel 5 P565 CH6 - Trace channel 6 P567 CH7 - Trace channel 7 P569 CH8 - Trace channel 8	0 to 727 [001] [002] [003] [004] [005] [006] [007] [073] -	<ul style="list-style-type: none"> Number of the parameter that will be recorded by the Trace function at the respective channel. The setting 0 means inactive channel. With the factory default settings (refer to the Trace function programming, Figure 12.1 on page 12-1) the following parameters are programmed with the Trace function: <p style="text-align: center;"><i>Table 11.67: Channels of trace</i></p> <table border="1" style="margin-left: auto; margin-right: auto;"> <thead> <tr> <th>Channel</th> <th>Parameter</th> <th>Description</th> </tr> </thead> <tbody> <tr> <td>1</td> <td>P001</td> <td>Speed Reference</td> </tr> <tr> <td>2</td> <td>P002</td> <td>Motor Speed</td> </tr> <tr> <td>3</td> <td>P003</td> <td>Motor Current</td> </tr> <tr> <td>4</td> <td>P004</td> <td>DC Link Voltage</td> </tr> <tr> <td>5</td> <td>P005</td> <td>Motor Frequency</td> </tr> <tr> <td>6</td> <td>P006</td> <td>Inverter Status</td> </tr> <tr> <td>7</td> <td>P007</td> <td>Output Voltage</td> </tr> <tr> <td>8</td> <td>P074</td> <td>Line voltage</td> </tr> </tbody> </table> <ul style="list-style-type: none"> When the channel is configured for P012 (status of the digital inputs) or P013 (status of the digital inputs) see Table 11.68 on page 11-99. 	Channel	Parameter	Description	1	P001	Speed Reference	2	P002	Motor Speed	3	P003	Motor Current	4	P004	DC Link Voltage	5	P005	Motor Frequency	6	P006	Inverter Status	7	P007	Output Voltage	8	P074	Line voltage
Channel	Parameter	Description																											
1	P001	Speed Reference																											
2	P002	Motor Speed																											
3	P003	Motor Current																											
4	P004	DC Link Voltage																											
5	P005	Motor Frequency																											
6	P006	Inverter Status																											
7	P007	Output Voltage																											
8	P074	Line voltage																											

Parameter	Range [Factory Setting] Unit	Description/Notes																																																																								
P556 CH1 Trace Mask	0 to 16 [0]	<ul style="list-style-type: none"> They define the record manner of the respective channel during trace acquisition. <p style="text-align: center;"><i>Table 11.68: Trace record type</i></p> <table border="1"> <thead> <tr> <th>Value</th> <th>Record Type</th> <th>DI</th> <th>DO</th> </tr> </thead> <tbody> <tr><td>0</td><td>Normal</td><td></td><td></td></tr> <tr><td>1</td><td>Only the bit 0</td><td>DI8</td><td>-</td></tr> <tr><td>2</td><td>Only the bit 1</td><td>DI7</td><td>RL5</td></tr> <tr><td>3</td><td>Only the bit 2</td><td>DI6</td><td>RL4</td></tr> <tr><td>4</td><td>Only the bit 3</td><td>DI5</td><td>RL3</td></tr> <tr><td>5</td><td>Only the bit 4</td><td>DI4</td><td>RL2</td></tr> <tr><td>6</td><td>Only the bit 5</td><td>DI3</td><td>RL1</td></tr> <tr><td>7</td><td>Only the bit 6</td><td>DI2</td><td>DO2</td></tr> <tr><td>8</td><td>Only the bit 7</td><td>DI1</td><td>DO1</td></tr> <tr><td>9</td><td>Only the bit 8</td><td>DI9</td><td>-</td></tr> <tr><td>10</td><td>Only the bit 9</td><td>DI10</td><td>-</td></tr> <tr><td>11</td><td>Only the bit 10</td><td>-</td><td>-</td></tr> <tr><td>12</td><td>Only the bit 11</td><td>-</td><td>-</td></tr> <tr><td>13</td><td>Only the bit 12</td><td>-</td><td>-</td></tr> <tr><td>14</td><td>Only the bit 13</td><td>-</td><td>-</td></tr> <tr><td>15</td><td>Only the bit 14</td><td>-</td><td>-</td></tr> <tr><td>16</td><td>Only the bit 15</td><td>-</td><td>-</td></tr> </tbody> </table>	Value	Record Type	DI	DO	0	Normal			1	Only the bit 0	DI8	-	2	Only the bit 1	DI7	RL5	3	Only the bit 2	DI6	RL4	4	Only the bit 3	DI5	RL3	5	Only the bit 4	DI4	RL2	6	Only the bit 5	DI3	RL1	7	Only the bit 6	DI2	DO2	8	Only the bit 7	DI1	DO1	9	Only the bit 8	DI9	-	10	Only the bit 9	DI10	-	11	Only the bit 10	-	-	12	Only the bit 11	-	-	13	Only the bit 12	-	-	14	Only the bit 13	-	-	15	Only the bit 14	-	-	16	Only the bit 15	-	-
Value	Record Type		DI	DO																																																																						
0	Normal																																																																									
1	Only the bit 0		DI8	-																																																																						
2	Only the bit 1		DI7	RL5																																																																						
3	Only the bit 2		DI6	RL4																																																																						
4	Only the bit 3		DI5	RL3																																																																						
5	Only the bit 4		DI4	RL2																																																																						
6	Only the bit 5		DI3	RL1																																																																						
7	Only the bit 6	DI2	DO2																																																																							
8	Only the bit 7	DI1	DO1																																																																							
9	Only the bit 8	DI9	-																																																																							
10	Only the bit 9	DI10	-																																																																							
11	Only the bit 10	-	-																																																																							
12	Only the bit 11	-	-																																																																							
13	Only the bit 12	-	-																																																																							
14	Only the bit 13	-	-																																																																							
15	Only the bit 14	-	-																																																																							
16	Only the bit 15	-	-																																																																							
P558 CH2 Trace Mask	-																																																																									
P560 CH3 Trace Mask																																																																										
P562 CH4 Trace Mask																																																																										
P564 CH5 Trace Mask																																																																										
P566 CH6 Trace Mask																																																																										
P568 CH7 Trace Mask																																																																										
P570 CH8 Trace Mask																																																																										

Parameter	Range [Factory Setting] Unit	Description/Notes						
<p>P571 Trace Activation</p>	<p>0 or 1 [0] -</p>	<ul style="list-style-type: none"> ■ It programs the trace function, initiating its operation. <div style="border: 1px solid black; padding: 10px; margin-top: 10px;"> <p> NOTE! The trace programming becomes active when this parameter changes from inactive to active. Thus, if the trace function is active and the trace parameters are reprogrammed, those changes will only go into effect when trace is disabled (P571 = 0) and then enabled again (P571 = 1).</p> </div> <p style="text-align: center; margin-top: 10px;"><i>Table 11.69: Trace activation</i></p> <table border="1" style="margin-left: auto; margin-right: auto;"> <thead> <tr> <th>P571</th> <th>Trace</th> </tr> </thead> <tbody> <tr> <td>0</td> <td>Inactive</td> </tr> <tr> <td>1</td> <td>Active</td> </tr> </tbody> </table>	P571	Trace	0	Inactive	1	Active
P571	Trace							
0	Inactive							
1	Active							
<p>P572 Trace Memory Percentage</p>	<p>1 to 100 [100] 1%</p>	<ul style="list-style-type: none"> ■ It defines the percentage of the available memory that will be used for the Trace function recording. ■ When the user wants short time intervals, then values smaller than 100 % could be useful for the visualization at the analog outputs, and in the data transfer to the SuperDrive software. ■ In order to calculate the memory available for each channel when P572 is different from 100 %, one must simply consider the total memory of each board as: <div style="text-align: center; margin: 10px 0;"> $P572/100 \times \text{total board memory}$ </div> <p>Example: Memory available for each channel = 7.77kword.</p> <p>Sampling time equal to 500 μs (P553 = 1).</p> <p>If P572 = 100 %, then: 7770 x 500 ms = 3.885 s record.</p> <p>If P572 = 10 %, then: 777 x 500 ms = 0.3885 s record, and 90 % of the memory is not used.</p> <p>If P572 = 1 %, then: 77 x 500 ms = 0.0385 s record, and 90 % of the memory is not used.</p> 						

Parameter	Range [Factory Setting] Unit	Description/Notes								
P621 Sinusoidal Filter	0 to 2 [0] -	<ul style="list-style-type: none"> It enables proper modulation for operation with sinusoidal filter. <p style="text-align: center;"><i>Table 11.70: Sinusoidal Filter</i></p> <table border="1" style="margin-left: auto; margin-right: auto;"> <thead> <tr> <th>P621</th> <th>Function</th> </tr> </thead> <tbody> <tr> <td>0</td> <td>Inactive (OPP)</td> </tr> <tr> <td>1</td> <td>Active (SHE)</td> </tr> <tr> <td>2</td> <td>Active with current oversample (SHE)</td> </tr> </tbody> </table>	P621	Function	0	Inactive (OPP)	1	Active (SHE)	2	Active with current oversample (SHE)
P621	Function									
0	Inactive (OPP)									
1	Active (SHE)									
2	Active with current oversample (SHE)									
P622 Boost Final Frequency: IxR	0 to 9999 [4095] -	<ul style="list-style-type: none"> It determines the final actuation frequency of the manual torque boost. For further information, refer to parameter P136. The frequency is determined by the equation below: $P622 \text{ (Hz)} = \frac{P622}{8192} \cdot P403$								
P629 Synchronism Time OK	1 to 20 [1] s	<ul style="list-style-type: none"> Minimum time the inverter must maintain the phase error between the line voltage and the inverter output voltage smaller than the setting in P632 so as to signal it as synchronism OK. 								
P630 Synchronism Timeout	20 to 240 [60] s	<ul style="list-style-type: none"> Time out of synchronism with the line. Time counted from the activation of the DI of the MVC4, which starts the search until the signaling of synchronism OK. If this time is exceeded, A008 will be indicated. 								
P631 DI13 Delay	0 to 3000 [170] x500µs	<ul style="list-style-type: none"> Delay of DI13 of the MVC3 board, used to disable the inverter after the transfer. This time is used to compensate the delay on the transfer circuit, preventing the motor from remaining for a time interval without voltage. 								
P632 Maximum Phase Error	0 to 9999 [1966] -	<ul style="list-style-type: none"> Phase error between the line voltage and the inverter voltage used together with P629 to indicate synchronism OK. $(P632 / 65536) \times 360^\circ = \text{value in degrees}$. 								
P636 Phase Adjustment	-32768 to 32767 [0] -	<ul style="list-style-type: none"> Parameter used to compensate the phase error between the voltage the inverter uses as reference for synchronism and the actual voltage in the point where the transfer will occur. Possible setting between $(-180^\circ \text{ and } +180^\circ)$. $(P636 / 65536) \times 360^\circ = \text{value in degrees}$. 								

11.9 PARAMETERS OF THE MVC3 ANALOG OUTPUTS - P652 TO P666

Parameter	Range [Factory Setting] Unit	Description/Notes																																																																																													
P652 Fast Analog Output Function AO1 MVC3	0 to 255 [2] -	<i>Table 11.71: Function of the analog outputs of the MVC3 board</i>																																																																																													
		<table border="1" style="width: 100%; border-collapse: collapse;"> <thead> <tr> <th style="text-align: center;">P652, P654, P656 and P658</th> <th style="text-align: center;">Function</th> <th style="text-align: center;">Full Scale</th> </tr> </thead> <tbody> <tr> <td style="text-align: center;">0</td> <td>Phase Current V</td> <td>5 V = P295</td> </tr> <tr> <td style="text-align: center;">1</td> <td>Phase Current W</td> <td>5 V = P295</td> </tr> <tr> <td style="text-align: center;">2</td> <td>Phase Current U</td> <td>5 V = P295</td> </tr> <tr> <td style="text-align: center;">3</td> <td>Output Frequency</td> <td>10 V = 120 Hz</td> </tr> <tr> <td style="text-align: center;">4</td> <td>Angle of the Fundamental Output Voltage</td> <td>10 V = +180°</td> </tr> <tr> <td style="text-align: center;">5</td> <td>Modulation Index</td> <td>5 V = 255</td> </tr> <tr> <td style="text-align: center;">17</td> <td>Reference of Voltage and Field Current for Synchronous Machine</td> <td>10 V = P462 (A) 10 V = P463 (V)</td> </tr> <tr> <td style="text-align: center;">18</td> <td>Position Adjustment of the Absolute Encoder</td> <td>10 V = +180°</td> </tr> <tr> <td style="text-align: center;">34</td> <td>Value fixe at 0 V</td> <td style="text-align: center;">-</td> </tr> <tr> <td style="text-align: center;">35</td> <td>Value fixe at 10 V</td> <td style="text-align: center;">-</td> </tr> <tr> <td style="text-align: center;">36</td> <td>Value fixe at -10 V</td> <td style="text-align: center;">-</td> </tr> <tr> <td style="text-align: center;">37</td> <td>Voltage between Phase A and B Measured on the Line ISOX Board</td> <td>5 V = V_{AB} Rated</td> </tr> <tr> <td style="text-align: center;">38</td> <td>Voltage between Phase B and C Measured on the Line ISOX Board</td> <td>5 V = V_{BC} Rated</td> </tr> <tr> <td style="text-align: center;">60</td> <td>Temperature of Phase U</td> <td>0 V = -20° 10 V = 200 °C</td> </tr> <tr> <td style="text-align: center;">61</td> <td>Temperature of Phase V</td> <td>0 V = -20° 10 V = 200 °C</td> </tr> <tr> <td style="text-align: center;">62</td> <td>Temperature of Phase W</td> <td>0 V = -20° 10 V = 200 °C</td> </tr> <tr> <td style="text-align: center;">66</td> <td>Inverter Status</td> <td style="text-align: center;">-</td> </tr> <tr> <td style="text-align: center;">67</td> <td>Total DC Link Voltage</td> <td>10 V = (2.7 x P296)</td> </tr> <tr> <td style="text-align: center;">86</td> <td>Indication of A073</td> <td>0 V = without 10 V = C/A73</td> </tr> <tr> <td style="text-align: center;">94</td> <td>Temperature of Phase UAp</td> <td>0 V = -20° 10 V = 200°</td> </tr> <tr> <td style="text-align: center;">95</td> <td>Temperature of Phase VAp</td> <td>0 V = -20° 10 V = 200°</td> </tr> <tr> <td style="text-align: center;">96</td> <td>Temperature of Phase WAp</td> <td>0 V = -20° 10 V = 200°</td> </tr> <tr> <td style="text-align: center;">100</td> <td>Value of Parameter P075</td> <td>5 V = 100 %</td> </tr> <tr> <td style="text-align: center;">187</td> <td>Value of Analog Input AI1 MVC3</td> <td style="text-align: center;">-</td> </tr> <tr> <td style="text-align: center;">188</td> <td>Torque Reference of the Inverter</td> <td>-10 = -200 %* 10 V = +200 %*</td> </tr> <tr> <td style="text-align: center;">216</td> <td>Ride Through 2 Active</td> <td>0 V = inactive 10 V = active</td> </tr> <tr> <td style="text-align: center;">230</td> <td>Junction Temperature of the IGBTs</td> <td>-10 V = -240° 0 V = 0° 10 V = 240°</td> </tr> <tr> <td style="text-align: center;">231</td> <td>Temperature of Phase UBp</td> <td>0 V = -20° 10 V = 200°</td> </tr> <tr> <td style="text-align: center;">232</td> <td>Temperature of Phase VBp</td> <td>0 V = -20° 10 V = 200°</td> </tr> <tr> <td style="text-align: center;">233</td> <td>Temperature of Phase WBp</td> <td>0 V = -20° 10 V = 200°</td> </tr> </tbody> </table>	P652, P654, P656 and P658	Function	Full Scale	0	Phase Current V	5 V = P295	1	Phase Current W	5 V = P295	2	Phase Current U	5 V = P295	3	Output Frequency	10 V = 120 Hz	4	Angle of the Fundamental Output Voltage	10 V = +180°	5	Modulation Index	5 V = 255	17	Reference of Voltage and Field Current for Synchronous Machine	10 V = P462 (A) 10 V = P463 (V)	18	Position Adjustment of the Absolute Encoder	10 V = +180°	34	Value fixe at 0 V	-	35	Value fixe at 10 V	-	36	Value fixe at -10 V	-	37	Voltage between Phase A and B Measured on the Line ISOX Board	5 V = V_{AB} Rated	38	Voltage between Phase B and C Measured on the Line ISOX Board	5 V = V_{BC} Rated	60	Temperature of Phase U	0 V = -20° 10 V = 200 °C	61	Temperature of Phase V	0 V = -20° 10 V = 200 °C	62	Temperature of Phase W	0 V = -20° 10 V = 200 °C	66	Inverter Status	-	67	Total DC Link Voltage	10 V = (2.7 x P296)	86	Indication of A073	0 V = without 10 V = C/A73	94	Temperature of Phase UAp	0 V = -20° 10 V = 200°	95	Temperature of Phase VAp	0 V = -20° 10 V = 200°	96	Temperature of Phase WAp	0 V = -20° 10 V = 200°	100	Value of Parameter P075	5 V = 100 %	187	Value of Analog Input AI1 MVC3	-	188	Torque Reference of the Inverter	-10 = -200 %* 10 V = +200 %*	216	Ride Through 2 Active	0 V = inactive 10 V = active	230	Junction Temperature of the IGBTs	-10 V = -240° 0 V = 0° 10 V = 240°	231	Temperature of Phase UBp	0 V = -20° 10 V = 200°	232	Temperature of Phase VBp	0 V = -20° 10 V = 200°	233	Temperature of Phase WBp	0 V = -20° 10 V = 200°
		P652, P654, P656 and P658	Function	Full Scale																																																																																											
		0	Phase Current V	5 V = P295																																																																																											
		1	Phase Current W	5 V = P295																																																																																											
		2	Phase Current U	5 V = P295																																																																																											
		3	Output Frequency	10 V = 120 Hz																																																																																											
		4	Angle of the Fundamental Output Voltage	10 V = +180°																																																																																											
		5	Modulation Index	5 V = 255																																																																																											
		17	Reference of Voltage and Field Current for Synchronous Machine	10 V = P462 (A) 10 V = P463 (V)																																																																																											
		18	Position Adjustment of the Absolute Encoder	10 V = +180°																																																																																											
		34	Value fixe at 0 V	-																																																																																											
		35	Value fixe at 10 V	-																																																																																											
		36	Value fixe at -10 V	-																																																																																											
		37	Voltage between Phase A and B Measured on the Line ISOX Board	5 V = V_{AB} Rated																																																																																											
		38	Voltage between Phase B and C Measured on the Line ISOX Board	5 V = V_{BC} Rated																																																																																											
		60	Temperature of Phase U	0 V = -20° 10 V = 200 °C																																																																																											
		61	Temperature of Phase V	0 V = -20° 10 V = 200 °C																																																																																											
		62	Temperature of Phase W	0 V = -20° 10 V = 200 °C																																																																																											
		66	Inverter Status	-																																																																																											
		67	Total DC Link Voltage	10 V = (2.7 x P296)																																																																																											
		86	Indication of A073	0 V = without 10 V = C/A73																																																																																											
		94	Temperature of Phase UAp	0 V = -20° 10 V = 200°																																																																																											
		95	Temperature of Phase VAp	0 V = -20° 10 V = 200°																																																																																											
		96	Temperature of Phase WAp	0 V = -20° 10 V = 200°																																																																																											
		100	Value of Parameter P075	5 V = 100 %																																																																																											
		187	Value of Analog Input AI1 MVC3	-																																																																																											
		188	Torque Reference of the Inverter	-10 = -200 %* 10 V = +200 %*																																																																																											
		216	Ride Through 2 Active	0 V = inactive 10 V = active																																																																																											
		230	Junction Temperature of the IGBTs	-10 V = -240° 0 V = 0° 10 V = 240°																																																																																											
231	Temperature of Phase UBp	0 V = -20° 10 V = 200°																																																																																													
232	Temperature of Phase VBp	0 V = -20° 10 V = 200°																																																																																													
233	Temperature of Phase WBp	0 V = -20° 10 V = 200°																																																																																													
		(*) Torque percentage regarding the motor torque.																																																																																													

Parameter	Range [Factory Setting] Unit	Description/Notes
		 NOTE! For other options not described in Table 11.71 on page 11-102 contact WEG Technical Assistance.
P653 Fast Analog Output Gain AO1 MVC3	0 to 9.999 [1.000] -	<ul style="list-style-type: none"> It sets the gain of analog output AO1 of the MVC3 board.
P654 Fast Analog Output Function AO2 MVC3	0 to 255 [5] -	<ul style="list-style-type: none"> Refer to Table 11.71 on page 11-102 for further details regarding the functions of the analog outputs of the MVC3 board.
P655 Fast Analog Output Gain AO2 MVC3	0 to 9.999 [1.000] -	<ul style="list-style-type: none"> It sets the gain of analog output AO2 of the MVC3 board.
P656 Fast Analog Output Function AO3 MVC3	0 to 255 [2] -	<ul style="list-style-type: none"> Refer to Table 11.71 on page 11-102 for further details regarding the functions of the analog outputs of the MVC3 board.
P657 Fast Analog Output Gain AO3 MVC3	0 to 9.999 [1.000] -	<ul style="list-style-type: none"> It sets the gain of analog output AO3 of the MVC3 board.
P658 Fast Analog Output Function AO4 MVC3	0 to 255 [5] -	<ul style="list-style-type: none"> Refer to Table 11.71 on page 11-102 for further details regarding the functions of the analog outputs of the MVC3 board.
P659 Fast Analog Output Gain AO4 MVC3	0 to 9.999 [1.000] -	<ul style="list-style-type: none"> It sets the gain of analog output AO4 of the MVC3 board.
P663 Fast Analog Output Offset AO1 MVC3	-32768 to 32768 [-90] -	<ul style="list-style-type: none"> It sets the offset of analog output AO1 of the MVC3 board. -32768 = -100 % 32768 = 100 %
P664 Fast Analog Output Offset AO2 MVC3	-32768 to 32768 [-90] -	<ul style="list-style-type: none"> It sets the offset of analog output AO2 of the MVC3 board. -32768 = -100 % 32768 = 100 %
P665 Fast Analog Output Offset AO3 MVC3	-32768 to 32768 [-90] -	<ul style="list-style-type: none"> It sets the offset of analog output AO3 of the MVC3 board. -32768 = -100 % 32768 = 100 %

Parameter	Range [Factory Setting] Unit	Description/Notes
P666 Fast Analog Output Offset AO4 MVC3	-32768 to 32768 [-90] -	<ul style="list-style-type: none"> It sets the offset of analog output AO4 of the MVC3 board. -32768 = -100 % 32768 = 100 %

11.10 PARAMETERS OF THE MVC4 ANALOG INPUT AI5

Parameter	Range [Factory Setting] Unit	Description/Notes										
P721 ⁽¹⁾ Analog Input AI5 Function (Isolated unipolar analog input)	0 [0] -	<p><i>Table 11.72: Analog input AI5 function</i></p> <table border="1"> <thead> <tr> <th>P721</th> <th>Function</th> </tr> </thead> <tbody> <tr> <td>0</td> <td>P221/P222</td> </tr> </tbody> </table> <ul style="list-style-type: none"> When the option 0 (P221/P222) is selected, AI5 is able to receive the speed reference, which will be subjected to the speed limits (P133 and P134) and ramp action (P100 to P103), providing that it has been programmed so in P221 and/or P222. Refer to the Figure 11.26 on page 11-48. 	P721	Function	0	P221/P222						
P721	Function											
0	P221/P222											
P722 Analog Input AI5 Gain	0.000 to 9.999 [1.000] 0.001	<ul style="list-style-type: none"> Refer to the P234 description. 										
P723 ⁽¹⁾ Analog Input AI5 Signal Type	0 to 3 [0] -	<p><i>Table 11.73: Analog input AI5 signal type</i></p> <table border="1"> <thead> <tr> <th>P723</th> <th>AI5</th> </tr> </thead> <tbody> <tr> <td>0</td> <td>(0 to 10) V/(0 to 20) mA</td> </tr> <tr> <td>1</td> <td>(4 to 20) mA</td> </tr> <tr> <td>2</td> <td>(10 to 0) V/(20 to 0) mA</td> </tr> <tr> <td>3</td> <td>(20 to 4) mA</td> </tr> </tbody> </table> <ul style="list-style-type: none"> Inverse reference is obtained with the options 2 and 3, i.e., the maximum speed is obtained with the minimum reference. Set the S3.1 switch on the MVC4 control board to the on position when a current signal is used at the analog input AI5. 	P723	AI5	0	(0 to 10) V/(0 to 20) mA	1	(4 to 20) mA	2	(10 to 0) V/(20 to 0) mA	3	(20 to 4) mA
P723	AI5											
0	(0 to 10) V/(0 to 20) mA											
1	(4 to 20) mA											
2	(10 to 0) V/(20 to 0) mA											
3	(20 to 4) mA											
P724 Analog Input AI5 Offset	0.0 to +100.0 [0.0] 0.1 %	<ul style="list-style-type: none"> Refer to the P234 description. 										

11.11 OTHER MVW-01 PARAMETERS

Parameter	Range [Factory Setting] Unit	Description/Notes
P725 Minimum Coasting Time	0 to 300 [0] 1 s	<ul style="list-style-type: none"> The minimum coasting time determines for how long the inverter will not be accepting General Enable or Start/Stop commands after a coasting stop (P232 = 1 - General Disable). By programming 0 at this parameter the function is deactivated.

Parameter	Range [Factory Setting] Unit	Description/Notes										
P727 Parallelism of Inverters	0 to 3 [0] -	<p><i>Table 11.74: Parallelism of Inverters</i></p> <table border="1"> <thead> <tr> <th>P727</th> <th>Configuration</th> </tr> </thead> <tbody> <tr> <td>0</td> <td>Normal (3L1)</td> </tr> <tr> <td>1</td> <td>Parallel 2x (3L2)</td> </tr> <tr> <td>2</td> <td>Parallel 3x (3L3)</td> </tr> <tr> <td>3</td> <td>Parallel 4x (3L4)</td> </tr> </tbody> </table>	P727	Configuration	0	Normal (3L1)	1	Parallel 2x (3L2)	2	Parallel 3x (3L3)	3	Parallel 4x (3L4)
P727	Configuration											
0	Normal (3L1)											
1	Parallel 2x (3L2)											
2	Parallel 3x (3L3)											
3	Parallel 4x (3L4)											
P740 Function of Analog Input AI1 MVC3	0 to 2 [0] -	<p><i>Table 11.75: Function of analog input AI1 of the MVC3 board</i></p> <table border="1"> <thead> <tr> <th>P740</th> <th>Function</th> </tr> </thead> <tbody> <tr> <td>0</td> <td>Not used</td> </tr> <tr> <td>1</td> <td>Torque Reference</td> </tr> <tr> <td>2</td> <td>Limit Current</td> </tr> </tbody> </table>	P740	Function	0	Not used	1	Torque Reference	2	Limit Current		
P740	Function											
0	Not used											
1	Torque Reference											
2	Limit Current											
P741 Analog Input Gain AI1 MVC3	0 to 9999 [1000] -	<ul style="list-style-type: none"> It sets the gain of analog input AI1 of the MVC3 board. 										
P742 Analog Input Offset AI1 MVC3	-1000 to 1000 [0] 1 %	<ul style="list-style-type: none"> It sets the offset of analog input AI1 of the MVC3 board. 										
P743 Modulation Levels	0 to 1 [0] -	<p><i>Table 11.76: Modulation levels</i></p> <table border="1"> <thead> <tr> <th>P743</th> <th>Function</th> </tr> </thead> <tbody> <tr> <td>0</td> <td>Three level (3L)</td> </tr> <tr> <td>1</td> <td>Five levels (5L)</td> </tr> </tbody> </table>	P743	Function	0	Three level (3L)	1	Five levels (5L)				
P743	Function											
0	Three level (3L)											
1	Five levels (5L)											
P744 Function of Analog Input AI2 MVC3	0 and 1 [0] -	<p><i>Table 11.77: Function of analog input AI2 of the MVC3 board</i></p> <table border="1"> <thead> <tr> <th>P744</th> <th>Function</th> </tr> </thead> <tbody> <tr> <td>0</td> <td>Not used</td> </tr> <tr> <td>1</td> <td>Field Current</td> </tr> </tbody> </table>	P744	Function	0	Not used	1	Field Current				
P744	Function											
0	Not used											
1	Field Current											
P745 Analog Input Gain AI2 MVC3	0 to 9999 [1000] -	<ul style="list-style-type: none"> It sets the gain of analog input AI2 of the MVC3 board. 										
P746 Analog Input Offset AI2 MVC3	-1000 to 1000 [0] 1 %	<ul style="list-style-type: none"> It sets the offset of analog input AI2 of the MVC3 board. 										
P950 Motor Type	0 to 2 [0] -	<ul style="list-style-type: none"> It selects the type of the motor to be driven by the inverter, where each option presents specific configuration parameters. <p><i>Table 11.78: Motor Types</i></p> <table border="1"> <thead> <tr> <th>P950</th> <th>Function</th> </tr> </thead> <tbody> <tr> <td>0</td> <td>Induction Motor</td> </tr> <tr> <td>1</td> <td>Synchronous motor with brushes</td> </tr> <tr> <td>2</td> <td>Brushless synchronous motor</td> </tr> </tbody> </table>	P950	Function	0	Induction Motor	1	Synchronous motor with brushes	2	Brushless synchronous motor		
P950	Function											
0	Induction Motor											
1	Synchronous motor with brushes											
2	Brushless synchronous motor											

12 SPECIAL FUNCTIONS

12.1 TRACE FUNCTION

- The trace function is used to record MVW-01 parameters (e.g., current, voltage, speed) when a certain event occurs in the system (e.g., alarm/fault, high current, etc.). This system event, for unleashing the data storage process, is called trigger, and is of fundamental importance in the trace function.
- The data stored by the trace function can be viewed in the inverter analog outputs or on a computer by means of the Super Drive software application.

12.1.1 Trigger

- Trigger can be understood as the element that defines the beginning of a process that, in this case, is recording and storing data of the programmed trace channels in the memory of the control boards.
- The trigger can be programmed in several manners. Any MVW-01 available parameter can be used as trigger, and this parameter is programmed in P550. The value of the parameter programmed in P550 is compared to a reference set by the user in the parameter P551. The type of comparison between the parameter and the reference is established programming P552 and can be =, <>, >, <, inverter fault or binary selection ⁽¹⁾ (or bit mask). When the comparison condition is fulfilled, the storage of the trace channels is triggered (refer to the [Figure 12.1 on page 12-1](#)).

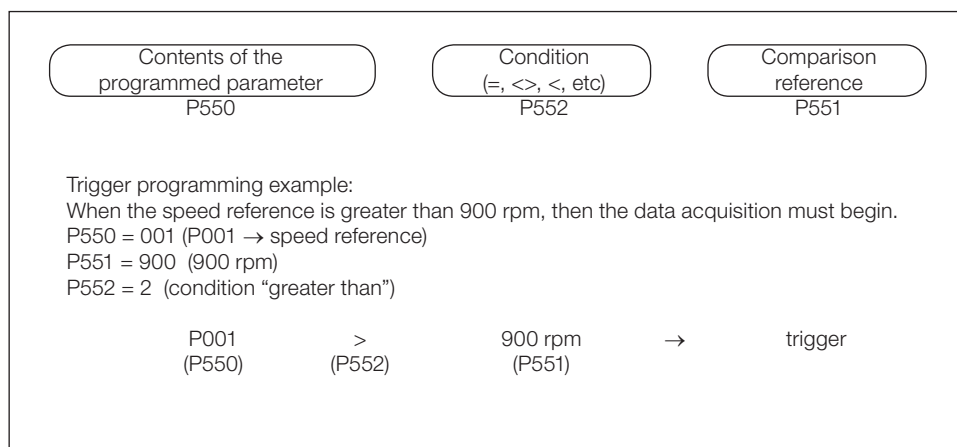

Figure 12.1: Trigger programming example

(1) The binary selection has the purpose of allowing the use of a specific digital input or output as trigger. This procedure is necessary because there is no single inverter parameter related to each digital input or output, so that the status of all the digital inputs is presented at parameter P012, and in a similar manner, P013 presents the digital output status. Therefore, it is necessary to determine which parameter bit contains the desired input or output information (for more details, refer to the P552 description).



ATTENTION!

If a TRIGGER condition that is fulfilled immediately after the data capture is enabled (P571 = 1) is programmed, then the TRACE function data will not be valid.

E.g.: I. Acceleration ramp programmed with 10.0 seconds (P100 = 10.0).

II. TRIGGER programmed for P100 = 10.0 seconds (P550 = 100 and P551 = 100).

III. Data capture enabled (P571 = 1).

IV. TRIGGER occurs immediately because P100 was already programmed with 10.0 seconds.

In this condition, data are not valid.

12.1.2 Data Access

Data stored by the Trace function can be visualized at the inverter analog outputs or on a PC by using the SuperDrive software. There are eight channels available for the Trace function, and they are all synchronized with the trigger (the trigger simultaneously unleashes the storage of all the active channels). Any MVW-01 parameter (except P000) can be stored in one of the eight trace channels.

12.1.3 Memory

The memory used by the Trace function is able to automatically assume several size configurations, depending on the parameters selected in each trace channel (from 31.08 kword up to 248.64 kword of total memory).

* 1 kword = 1000 words.

Each trace channel is able to store any inverter parameter, with the exception of P000. Some of the parameters are handled by the MVC3 control board and the others by the MVC4 control board. The list of the parameters handled by the MVC4 board is presented next:

P002, P003, P004, P005, P007, P009, P022, P025, P026, P027, P030, P031, P032, P033, P034, P035, P036, P037, P052, P053, P055, P056, P057, P058, P059, P070, P071, P072, P073, P074, P075, P076.

In order to allow the analysis of data captured by the Trace function, it is important that all the channels have the same size, not mattering whether the MVC3 or the MVC4 control board controls them. As can be observed in the [Figure 12.2 on page 12-2](#), each board makes available a different total Trace function memory and, therefore, there are some important implications to be observed when it comes to knowing the total allocated memory for each channel.

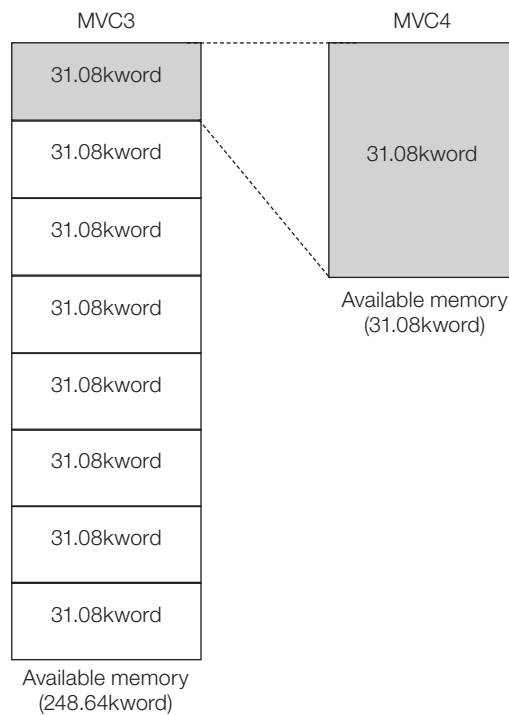

Figure 12.2: Example of Trace function memory distribution by the control boards

In general, the size of each channel is limited by the smaller memory available on the MVC4 board, in case that there are MVC4 channels programmed. Then maximum size of each channel will be the MVC4 memory size (31.08 kword) divided by the number of used MVC4 channels.



NOTE!

P572 defines the percentage of the memory used in each board. The factory default setting is 100 % and the examples given here use this total memory capacity (100 %). For more information, refer to the P572 description.

Thus, the maximum total memory (248.64 kword) use situation will be possible when the user selects only parameters handled by the MVC3 control board, or when the user selects only one parameter from the MVC4 and seven from the MVC3 board. The minimum total memory (31.08 kword) will be used when only parameters handled by the MVC4 board were selected.

In any other case an intermediate size configuration will be used, limited by the memory available in the MVC4 board and depending, therefore, on the number of channels with MVC4 parameters. In this way, the memory is distributed according to the number of active channels on each board.

EXAMPLE 1: trace function programmed for 3 MVC4 channels.

MVC4 RAM= 31.08kword.

RAM area per MVC4 channel = $31.08 / 3 = 10.36$ kword.

RAM area per MVC3 channel = 0kword.

RAM area per channel = 10.36kword → 10360 points per channel.

Total RAM use = 3×10.36 kword = 31.08kword.

Therefore, the MVC4 board handles 3 channels, with use 10.36 kword of memory each one.

The MVC3 control board has a memory capacity 8 times greater than the MVC4; therefore, the memory reserved for each channel handled by the MVC3 is equal to the size of each channel handled by the MVC4, regardless of the allocated RAM memory area size. If there are no channels handled by the MVC4 board, then the size of each MVC3 handled channel is equal to the total RAM area (248.64 kword) divided by the number of programmed channels.

EXAMPLE 2: trace function programmed with 4 MVC4 handled channels and 2 MVC3 channels.

MVC4 RAM = 31.08kword.

RAM area per MVC4 channel = $31.08 / 4 = 7.77$ kword.

RAM area per MVC3 channel = 7.77kword.

RAM area per channel = 7.77kword → 7770 points per channel.

Total RAM use = 6×7.77 kword = 46.62kword.

12.1.4 Sampling

Sampling time is the time interval between the points stored by the Trace function (refer to the [Figure 12.3 on page 12-3](#)). If, for instance, a 1 ms (1 millisecond or 1/1000 second), it means that 1000 points will be stored per second (if there is enough memory available).

The sampling time is the same for all the channels programmed in the Trace function, and it can be programmed as a whole number multiplying 500 μ s. If a 2 ms sampling time ($4 \times 500 \mu$ s) is programmed for the example 2, then 15.54 seconds of information will be stored in each channel (7770×2 ms).

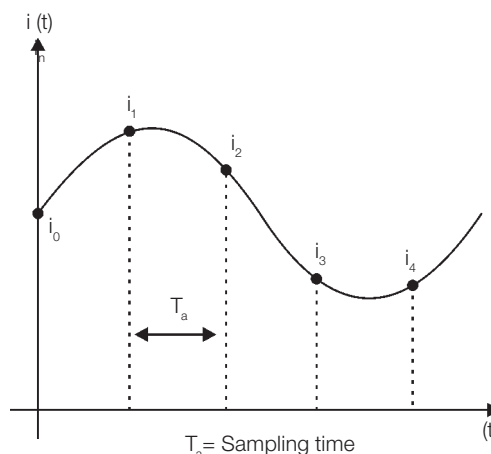

Figure 12.3: Example of Trace function signal sampling

12.1.5 Pre-Trigger

It is possible to program a pre-trigger time as a percentage of the total record (see the [Figure 12.4 on page 12-4](#)), meaning that part of the Trace function data before the trigger event will be stored. If a 50 % pre-trigger is programmed for the example 2, then 7.77 sec data before the trigger and 7.77 sec after, will be stored.

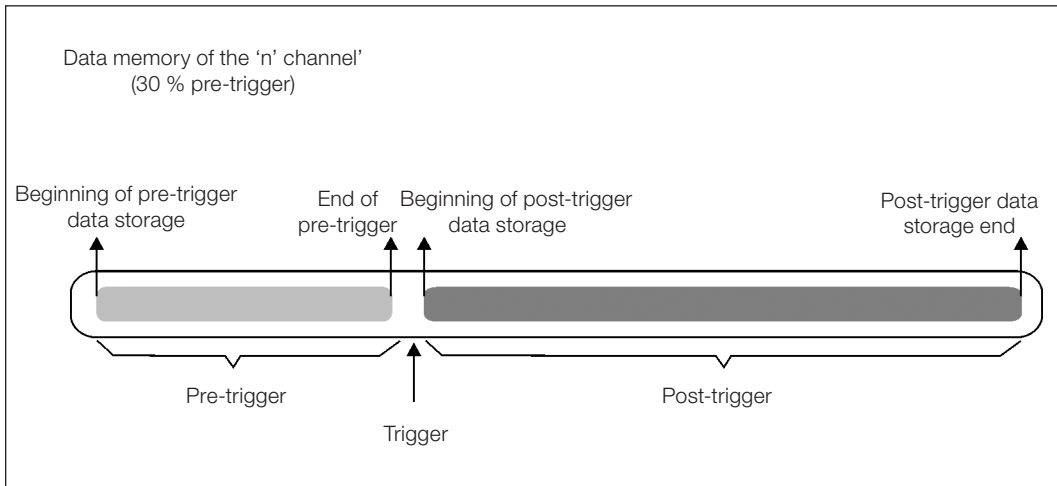

Figure 12.4: Example of Trace function data distribution for one channel with 30 % programmed pre-trigger

12.1.6 Trace Function Use and Programming Example

The first step to use the Trace function is to enable the parameters for the trace by programming P203 = 2 (Trace) or P203 = 3 (Trace + PID), so that the configuration parameters (P550 to P572) become accessible.

The factory default settings for the Trace function may be applied by the user as a reference, and if convenient, as the programming base for other trace configurations.

This standard configuration presents trigger caused by inverter fault and the default parameters programmed at the trace channels. Data for this programming can be observed in the [Table 12.1 on page 12-4](#).

Table 12.1: Standard Trace programming data

Parameter	Description	Programming
P550	Trigger Parameter	(0)
P551	Trigger Value	(0)
P552	Trigger Condition	(4) Fault trip
P553	Sampling Time	(1) 500 ms
P554	Pre-Trigger Percentage	50 %
P555	CH1 - Channel 1	(1) P001 - Speed Reference
P557	CH1 - Channel 2	(2) P002 - Motor Speed
P559	CH1 - Channel 3	(3) P003 - Motor Current
P561	CH1 - Channel 4	(4) P004 - DC Link Voltage
P563	CH1 - Channel 5	(5) P005 - Motor Frequency
P565	CH1 - Channel 6	(6) P006 - Inverter Status
P567	CH1 - Channel 7	(7) P007 - Output Voltage
P569	CH1 - Channel 8	(74) P074 - Input Transformer Secondary Voltage
P572	Trace Memory Percentage	(100) 100 %

For this configuration, P550 and P551 can assume any value, because the trigger condition is an inverter fault trip, which is independent from the other trigger parameter configurations.

The memory size for each channel can be calculated in the following manner:

Number of MVC4 channels = 1 (P001).

Trace Memory Percentage (P572) = 100 %.

MVC4 board total RAM = 31.08kword * 100 % = 31080words.

RAM area per channel on the MVC4 board = 31080 / 1 = 31080words.

Number of MVC3 channels = 7 (P002, P003, P004, P005, P006, P007 and P074).

RAM area per MVC3 channel = 31080words (same size as the MVC4 channel).

RAM area per channel = 31.08kword → 31080 points per channel.

TTotal RAM = 8 x 31.08kword = 248.64kword.

The function can be enabled for the programmed data acquisition by setting $P571 = 1$ (active). In this condition the Trace function is storing the pre-trigger (50 %) data and the parameter P029 (Trace Function Status) shows (1) Waiting for trigger.

When the inverter trips with a fault, then the trace memory will be filled with the post-trigger (50 %) data and P029 will indicate (2) Triggered.

When the post-trigger data acquisition is complete, then P029 will indicate Trace finished. At this point the data can be visualized at the analog outputs, by programming them (P251, P253, P255, P257, P259 and P261) with the respective trace channel. If the function is not in the Trace finished state ($P029 = 3$), the analog outputs programmed for those channels will output a zero value.

12.1.7 Example of Use and Trigger Configuration

Case study: obtain the voltage behavior of DC link when a line loss occurs with the Ride-Through function active.

For an inverter with rated voltage of 4160 V, we will have a rated voltage on the DC link of 5600 V. As we wish to obtain the wave form of the link voltage when a specific fault occurs (line loss), it is not feasible to configure the trigger by the fault occurrence, since any fault will meet such condition. For this situation, we must configure the Trigger by the DC link voltage itself, since it tends to zero when the line loss occurs. In the following example, after the DC link has rated voltage, we can activate the trace function (P571) and observe its status (P029).

Example of configuration:

Parameter	Value	Description
P550	4	P004
P551	4200	4200 V
P552	<	$P004 < 4200$ V
P553	10	$10 \times 500 \mu\text{s}$
P554	25	25 % of Pre-Trigger
P555	4	It stores data of P004
P556	000	No mask
P571	1	Active (activate after the DC link has rated voltage)

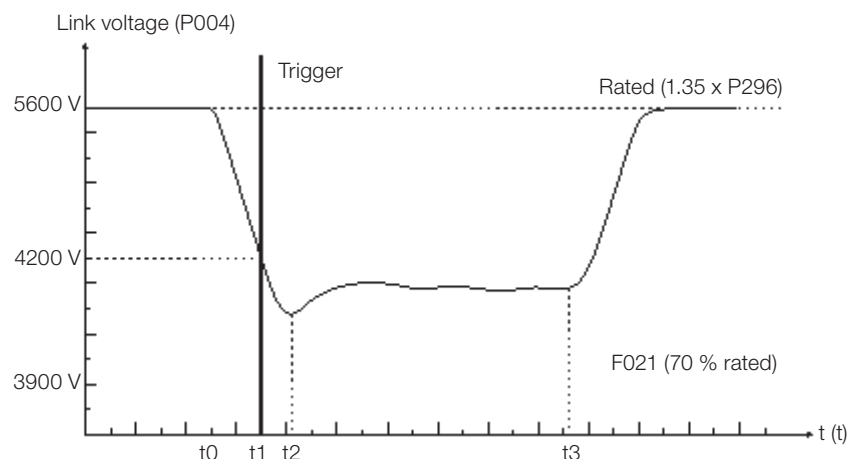

- t_0 - line loss
- t_1 - trigger of trace function.
- t_2 - actuation of Ride-through.
- t_3 - line feedback.

Figure 12.5: Wave form of the DC link voltage obtained by the trace function

12.2 PID REGULATOR

- The MVW-01 has a PID regulator function, which can be used to control a closed loop process. That function consists of a controller with proportional, integral and derivative gain, superposed to the normal MVW-01 speed control.
- In order to keep the process variable (the one to be controlled - water level in a reservoir for instance) at the value adjusted with the setpoint, the speed will be varied automatically by the PID controller.
- That regulator is able, for instance, to control the flow in a pipeline by means of flow feedback applied to the analog input AI2 or AI3 (selected through P524) and setpoint according to P221 or P222 definition (e.g., AI1), with the inverter driving the pump that is responsible for the pipeline flow.
- Other application examples are: Level or temperature control, dosage, etc.

The PID regulator function is activated by setting P203 = 1 or 3.

The [Figure 12.6 on page 12-8](#) presents the Academic PID Regulator block diagram.

The Academic PID Regulator transference function in the frequency domain is:

$$y(s) = K_p e(s) \left[1 + \frac{1}{sT_i} + sT_d \right]$$

Replacing the integrator by a sum and the derivative by the incremental quotient, we will obtain an approximate value for the discrete (recursive) transfer equation shown next:

$$y(kT_a) = y(k-1)T_a + K_p [e(kT_a) - e(k-1)T_a] + K_i e(k-1)T_a + K_d [e(kT_a) - 2e(k-1)T_a + e(k-2)T_a]$$

Where:

K_p (Proportional Gain): K_p = P520 x 4096.

K_i (Integral Gain): K_i = P521 x 4096 = [T_a/T_i x 4096].

K_d (Differential Gain): K_d = P522 x 4096 = [T_d/T_a x 4096].

T_a = 0.02 sec (PID regulator sampling time).

SP*: reference, maximum 13 bits (0 to 8191).

X: process variable (or controlled), read through AI2 or AI3, maximum 13 bits.

y(kT_a): current PID output, maximum 13 bits.

y(k-1)T_a: previous PID output.

e(kT_a): current error [SP*(k) - X(k)].

e(k-1)T_a: previous error [SP*(k-1) - X(k-1)].

e(k-2)T_a: error at two previous samplings [SP*(k-2) - X(k-2)].

The feedback signal must be connected to the analog input AI2' and AI3' (refer to the [Figure 11.32 on page 11-53](#) and [Figure 12.6 on page 12-8](#)).

The setpoint can be defined via:

- Keypad: parameter P525.
- Analog input AI1', AI2', AI3', AI4', AI5', (AI1'+ AI2')>0, (AI1'+ AI2'), Multispeed, Serial, Fieldbus.

Note: When P203 = 1 or 3, do not use the reference via EP P221/P222 = 7.

When the PID function is enabled (P203 = 1 or 3):

- One of the digital inputs from DI3 to DI10 can select between manual and automatic PID operation (P265 to P272).

- When the PID regulator function is activated (P203 = 1 or 3), the digital input DI3 is automatically programmed for the Manual/Automatic function (P265 = 15):

Table 12.2: *DIx operation mode*

DIx	PID status
0 (0V)	Manual
1 (24V)	Automatic

- P040 indicates the process variable value (feedback) in the selected scale and unit. In order to avoid the feedback analog input saturation during a regulation overshoot, the signal must vary between 0 and 9.0 V (0(4) to 18 mA). The adaptation between the setpoint and the feedback can be done changing the gain of the analog input selected as feedback (P238 for AI2 or P242 for AI3). The Process variable can also be visualized at the outputs AO1 to AO6, if it has been programmed at P251, P253, P255, P257, P259 and P261. This is also valid for the PID setpoint.
- The outputs DO1, DO2 and RL1 to RL5, can be programmed (P275 to P277, P279 to P282) for the functions Process Variable > VPx (P533) and Process Variable < VPy (P534).
- The functions JOG and Forward/Reverse remain disabled. Enable and Start/Stop commands are defined at P220, P224 and P227.
- If the setpoint is defined by P525 (P221 or P222 = 0), and the system is changed from manual to automatic, then P525 is automatically adjusted with the P040 value. In this case the transition from manual to automatic is smooth (there is no abrupt speed variation).

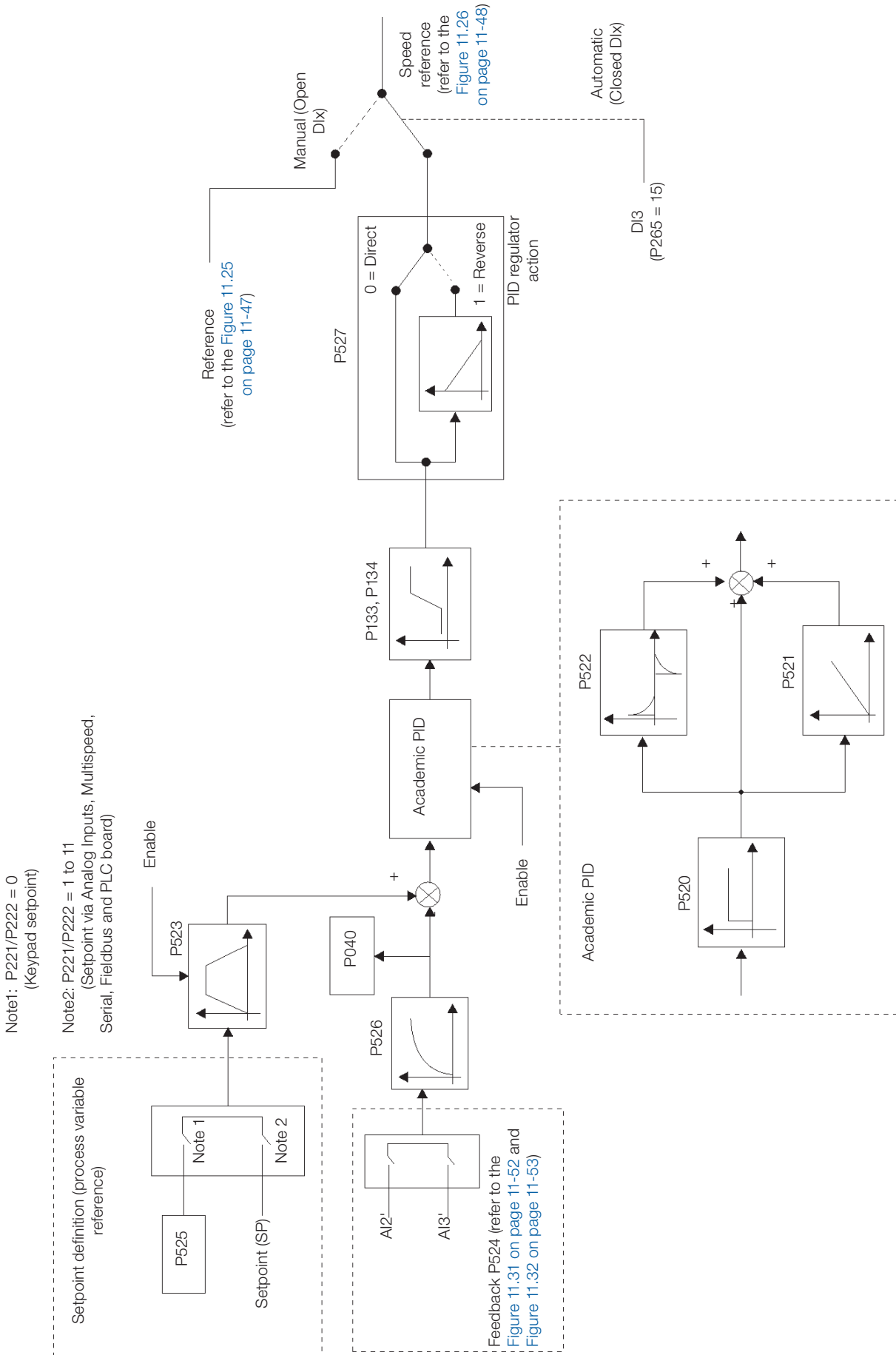

Figure 12.6: Academic PID regulator block diagram

12.3 LOAD SHARE FUNCTION "MASTER/SLAVE"

Conveyors belts and overhead cranes are classic examples of applications where the torque or position control is used to maintain the conveyor belt voltage within the limits during the operation, start and stop procedures or even in the transportation of materials in a rising or falling slope.

For motors connected to the same load, it is necessary to ensure a reliable load sharing. Such characteristic is best achieved with the use of multiple inverters operating in speed reference mode (Master) and torque limitation mode (Slave (s)).

Implementation Modes

Three modes to implement the load sharing function will be presented. For the first two modes, it is mandatory that the inverters involved in the process be set to vector operating mode. For most applications, the vector operating mode with speed or position sensor is recommended.

In order to implement the load sharing, the inverter assigned as master controls the load speed using all the other inverters of the process as actuators.

In the vector mode, there are two ways to implement the load sharing function: in the first one, the master inverter sends the slaves the torque reference signal; in the second one, it sends the torque reference limitation signal. The mode to be used must be analyzed for each application.

For operation in scalar mode with load sharing, all inverters must receive the same speed reference signal. This type of load sharing is called "droop" or negative slip.

The three implementation methods and the main parameters used in each method are shown below.

Torque Reference - Operation in Vector Mode

One of the possible ways to implement the load sharing function is by parameterizing the slave inverter(s) to follow an external torque reference, which will be sent by the master inverter.

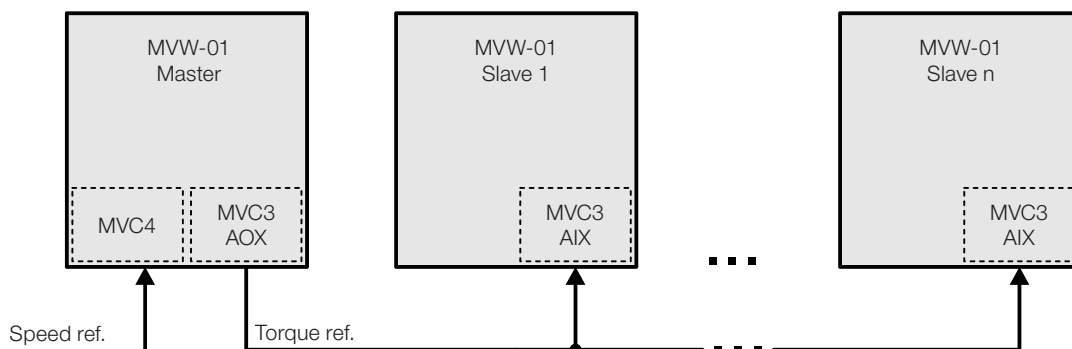

Figure 12.7: General operation scheme of the function

In order to do so, the inverters must be parameterized as follows:

Master:

Parameterize one of the analog outputs of the MVC3 control board to send the torque reference to the slave inverter(s). In the example below, the analog output AO1 is parameterized.

P652 (Analog Output 1 Function) = 188 (Inverter torque reference).

Slave(s):

On the slave inverter(s), it is necessary to parameterize an analog input of MVC3 board to receive the torque reference sent by the master inverter.

P740 (Analog Input 1 Function) = 1 (Torque reference).

NOTE! Observe the polarity of the analog ones at the moment of the connection between the inverters.

Limitation of the Torque Current - Operation in Vector Mode

As in the previous mode, the master inverter operates in speed control mode, while the slave inverter operates in torque current regulation mode. Besides the limit value of the torque current, the slave inverter(s) receives the speed reference signal; therefore, in a potential situation of sudden load reduction, the speed reference is saturated, thereby avoiding a possible sudden acceleration of the motor.

The speed reference signal sent to the slave inverter(s) must be set to a value slightly above the master inverter reference. It is recommended to apply an offset to the analog inputs of the slave(s) greater than 5 % added to the reference sent by the master inverter; the ideal value may vary according to the application.

NOTE! As the operation with negative torque reference is impossible, this method cannot be used for regenerative inverters or with dynamic braking.

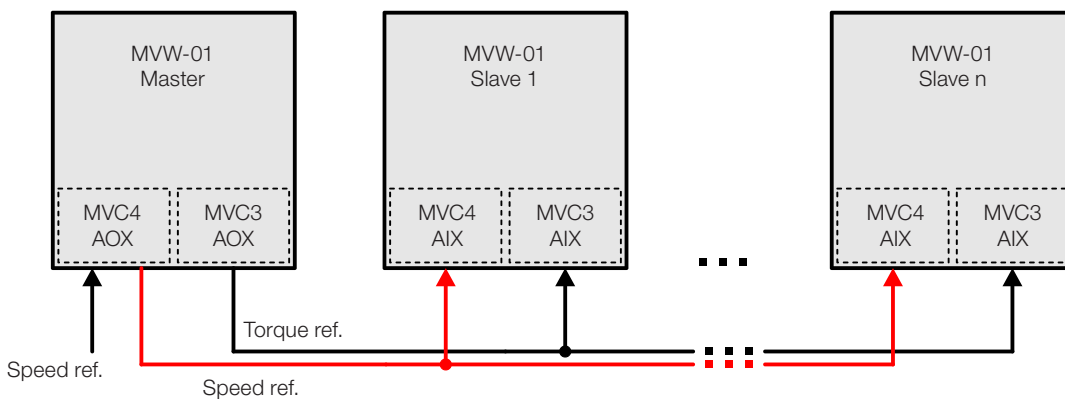

Figure 12.8: General operation scheme of the function

Therefore, the inverters must be parameterized as follows:

Master:

Parameterize one of the analog outputs of the MVC3 board to send the torque current limit to the slave inverter(s). The example below shows the parameterization of analog output AO1 of the MVC4 board to send the speed reference.

P652 (Analog Output 1 Function – MVC3) = 188 (Inverter torque reference).

P251 (Analog Output Function 1 – MVC4) = 0 (Speed reference).

Slave:

The slave inverter(s) requires the parameterization of an analog input of the MVC3 board to receive the torque current limit sent by the master inverter. For the speed reference, use the analog input AI1 of the MVC4 board, whose standard function is the speed reference signal.

P740 (Analog Input 1 Function - MVC3) = 2 (ICur. Lim.).

P221/P222 (Speed Reference Selection Local/Remote Situation) = 1 (AI1 - MVC4).

P236 (Input AI1 Offset) = 5.0 %.

P133 (Minimum Speed Reference) = set according to the application.

P134 (Maximum Speed Reference) = set according to the application; it must be 5 % above the maximum limit of the master inverter.

Negative Slip – Operation in Scalar Mode

This method to implement the load sharing function is limited to applications of induction motor drive. It is based on the decrease of the frequency according to the increase of load on the motor; thus there is a natural distribution of the loads.

Regardless of the chosen speed reference source, it must be sent to all inverters. Due to the low accuracy of analog inputs, its use as speed reference source is not recommended.

This method to implement the load sharing must not be used for applications that require dynamic performance, and it can only be considered when the inverters drive motors with the same characteristic slip.

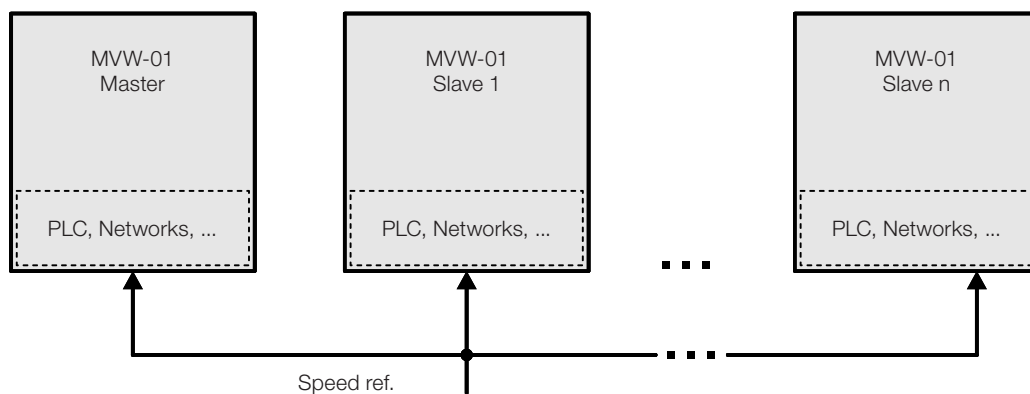

Figure 12.9: General operation scheme of the function

Therefore, the inverters must be parameterized as follows:

P138 (Rated slip) = the motor slip is recommended (negative signal).

P139 (Output current filter) = it is recommended to start with the standard value and gradually increment it if the system presents instability.

Besides the presented parameterization, the implementation of the load sharing function requires that all inverters involved in the process be enabled simultaneously; thus, the "General Enable" and "Run/Stop" signals must be sent to all inverters at the same time. There are several ways to meet this requirement and the most appropriate way will depend on each application.

The description given of the ways to implement the load sharing function intends neither to approach all possibilities of implementation, nor to detail all the aspects involved. The definition of the best implementation mode for a certain application, as well as the optimal adjustment of each mode must be defined by WEG engineering and application teams.

12.4 SYNCHRONOUS TRANSFER OR SYNCHRONOUS BYPASS FUNCTION

For applications where speed variation is not required during operation, the synchronous bypass function enables the motor to be accelerated through the inverter up to the rated operating frequency, and then the transfer to the supply line to occur. In this way, it is possible to eliminate the effects of the starting current related to a direct on-line start, and the frequency inverter is sized only for the motor starting condition.

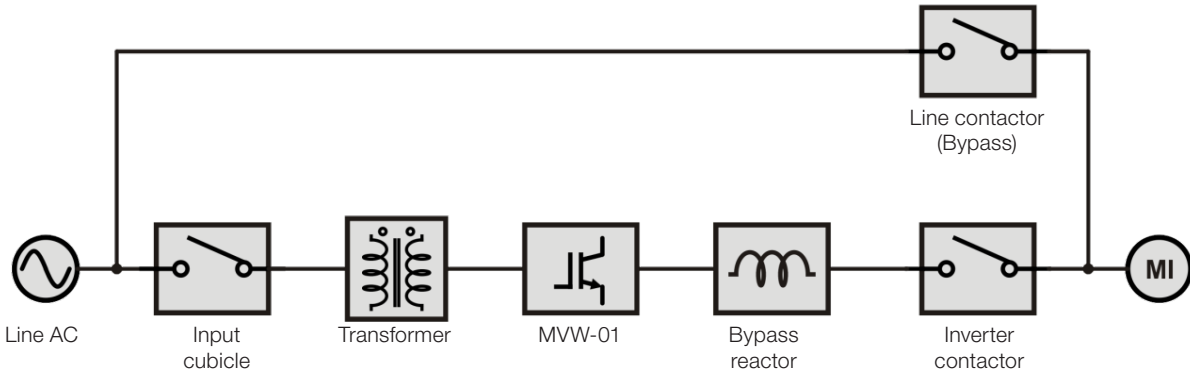

Figure 12.10: General scheme of synchronous transfer

Basic Settings

The synchronous transfer process involves accelerating the motor up to the rated speed, synchronizing the voltage imposed to the motor with the line voltage, and making the transfer to the line. For the transfer to occur properly and with minimal impact on the motor and on the inverter, a series of parameters must be carefully adjusted so as to ensure the phase synchronization, the minimum difference of the RMS value between the inverter and the line voltages and the timely occurrence of each step of the process.

Even with the correct setting of parameters related to the synchronous transfer process, it is necessary to use a reactor between the inverter and the motor in order to absorb differences between the inverter and the line voltage, thus protecting the inverter during the closing of the line contactor.

Therefore, after making all the start-up procedure for inverter with operation in normal mode, it is necessary to:

- Configure the motor voltage (**P400**) equal to the line voltage to which the motor will be transferred. In the operation with synchronous bypass, the inverter uses this value to calculate the RMS voltage that will be imposed to the motor when operating at rated frequency.
E.g.: motor nameplate voltage of 4000 V and line of 4160 V. Configure P400 = 4160 V.
- Configure the inverter in bypass mode (**P299 = 4**).
- Choose one of the DIs available on the MVC4 board (DI3 to DI10) and configure it to start the synchronous transfer (**P265 to P272 = 23 or 25**).
- Configure one DO (RL1 to RL5) to indicate that the synchronism with the line is “OK” (**P277 to P282 = 34**).

Parameterization Used for Most Applications

In addition to the aforementioned basic settings, other parameters must be set for the correct operation of the function. Below is a quick description of each parameter, as well as the setting used in most applications.

- **P629 = 2 s** Minimum time for which the inverter will have to keep the phase error between the input and output voltage lower than the setting in P632 so as to signal synchronism OK.
- **P630 = 60 s** Synchronism with the network time out. Time counted from the drive of the MVC4 DI, which starts searching until the signaling of synchronism OK. If this time is exceeded, A008 will be indicated.
- **P631 = adjusted in the application** Delay of DI13 of the PIC2 board used to disable the inverter after the bypass. This time is used to compensate the delay of the bypass circuit, preventing the motor from remaining for a period without voltage.
- **P632 = 1966** Phase error between the network and inverter voltage used in conjunction with P629 to indicate synchronism OK. (**P632/65536**) x 360° = value in degrees.

- **P636 = adjusted in the application** Parameter used to compensate the phase error between the voltage the inverter uses as reference for synchronism and the actual voltage in the point where the bypass will occur.

Adjust is possible between (-180° and +180°). **(P636/65536) x 360° = value in degrees.**

Operating Sequency

Figure 12.1 on page 12-1 describes all the operating sequence of the signals involved in the synchronous transfer process.

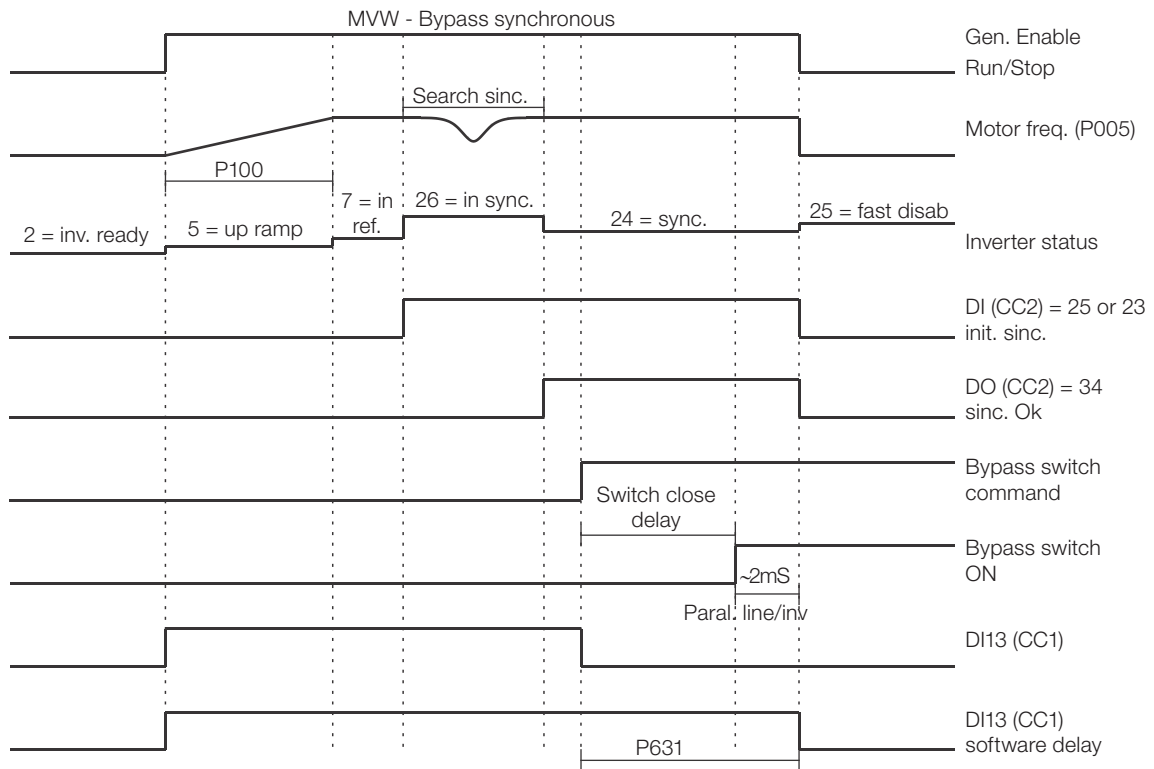

Figure 12.11: Operation diagram of the synchronous bypass function

12.5 SAFETY STOP FUNCTION

The Safety Stop function aims at providing the motor with a safe stop mode system through hardware, ensuring that the inverter will not spin the motor regardless of the software or auxiliary circuit.

Implementation Mode

As the MVW-01 features an auxiliary power supply of the measuring boards and Gate Drivers, it will be necessary to use an exclusive transformer/supply set for the Gate Drivers, thus enabling to turn them off independently of the measuring boards.

By turning off this supply we are ensuring that under no circumstances will the system go into operation again. For this purpose, we will use a safety relay certified for the function, containing inside two independent relays in relation to the drive and contacts.

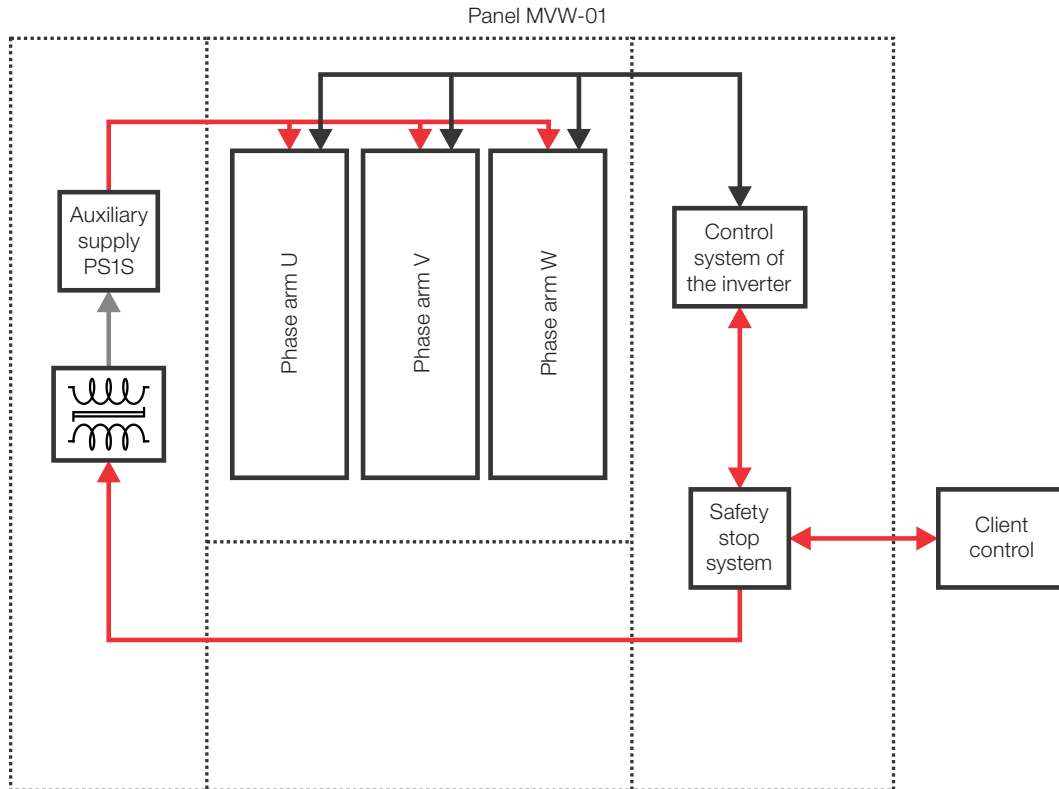

Figure 12.12: General operation scheme of the function

Hardware

To implement the system, a safety relay certified for this type of function will be used, according to the diagram in [Figure 12.3 on page 12-3](#).

In order to enable the Safety stop function, it is necessary to command the safety relay directly by commanding any of the emergency buttons connected in series shown in [Figure 12.13 on page 12-15](#). The relay, without influence of the inverter, will shut down the power of the Gate Drivers, inform the control about the change to the safe operating mode and send a feedback to the client.

On the inverter, the digital input DI15 of the MVC3 board (through the PIC board) is configured so that whenever it receives a signal of 24 V (high), the inverter, regardless of the routine it is running, immediately goes into the safe operating mode, inhibits the trigger signals of the switches and ignores all the IGBT, temperature of the arms and of the PS1 supply faults that may occur at this moment due to the power loss.

From the effective ingress of the inverter into the safe mode, the A165 alarm is signaled on the HMI, informing the inverter is locked for operation by the Safety Stop function.

On the MVC4 board, the relay outputs (RL1 to RL5) have the option 36 (Safety Stop). Such function provides the indication of the function in progress. The parameters for configuration of the relay outputs are: P277, P279, P280, P281 and P282.

Since this is a safety function, the implementation is performed through a relay that presents actuation redundancy and simultaneity in the activation mode. Such redundancy is used both in the disconnection of the supply and in the information to the control and feedback to the client.

If a fault occurs in one of the internal relays, the system is locked likewise; however, due to its internal self-monitoring, it will not go back into operation, requiring a check of the cause for the lock. Therefore, the supply of the Gate Drivers is turned off, and the IGBT and/or temperature of the arms fault and/or PS1 supply fault is indicated, and consequently the entire system is shut down (the main circuit breaker opens) due to operation fault.

The image below presents the electrical diagram of the Safety Stop function.

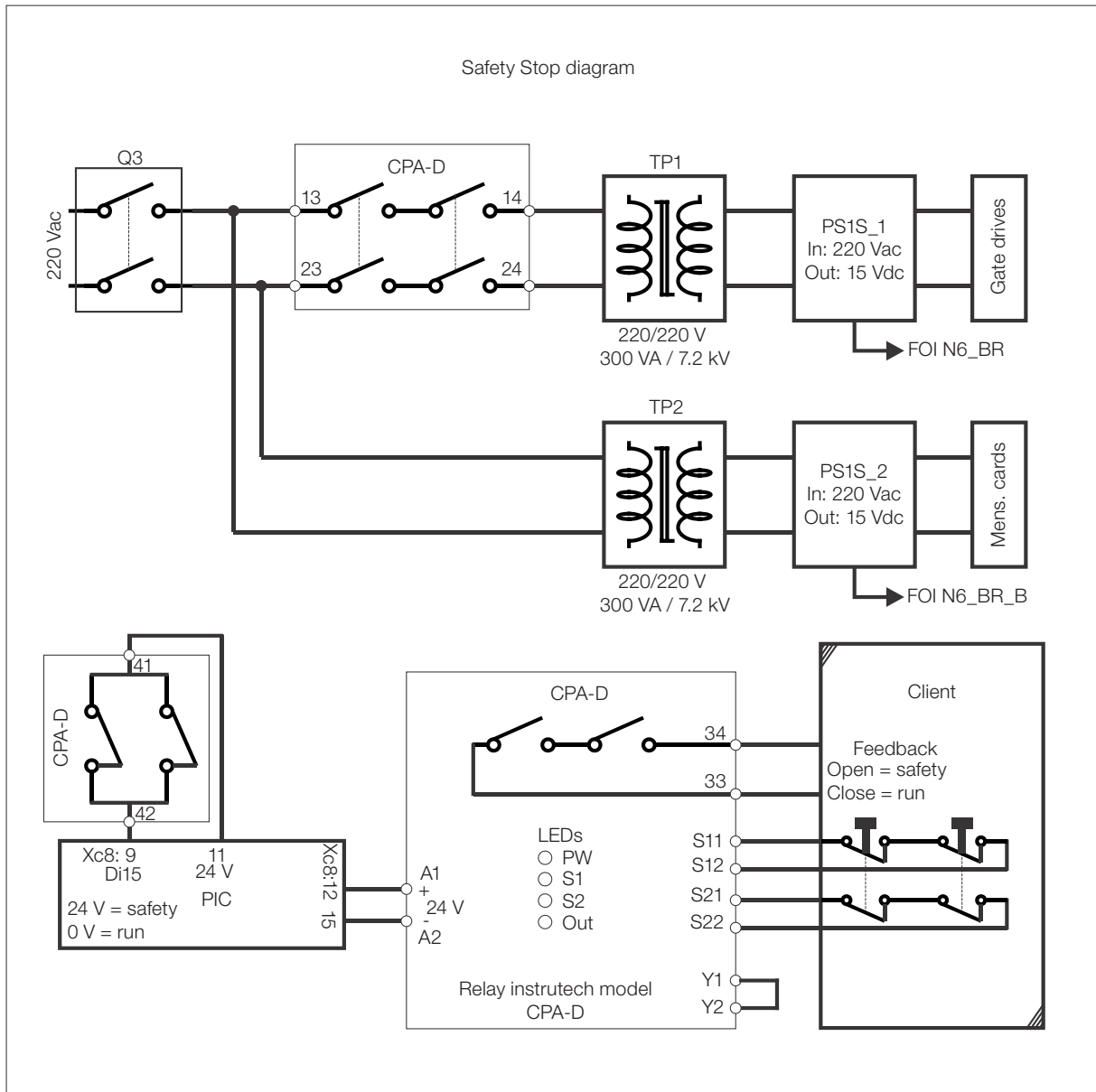

Figure 12.13: Electrical diagram of the Safety Stop function

The system leaves the safety stop function **100 ms** after the signal of digital input DI15 is removed, and the inverter begins to monitor all the faults again, accept commands of enable PWM and reset of alarm A165.

13 COMMUNICATION NETWORKS

The MVW-01 can be connected to communication networks allowing its control and parameterization. Therefore, it is necessary to install an optional electronic board according to the desired Fieldbus standard.



NOTE!

The chosen Fieldbus option can be specified in the suitable field of the MVW-01 model coding. In such case, the MVW-01 will be supplied with all the necessary components already installed in the product. In case of a later purchase of the Fieldbus optional kit, the user must install it.

13.1 FIELDBUS KIT

13.1.1 Installation of the Fieldbus Kit

The Fieldbus kit communication board is installed directly on the MVC4 control board, connected to the XC140 connector and fixed by spacers.



NOTE!

Follow the safety notes presented in the [Chapter 1 SAFETY NOTICES on page 1-1](#).

If a function expansion board (EBA/EBB) is already installed, it must be temporarily removed.

1. Power down control Rack.
2. Remove the bolt from the metallic spacer next to the XC140 connector (MVC4 board).
3. Carefully fit the male XC140 connector into the correspondent MVC4 connector. Verify the exact coincidence of all the XC140 connector pins ([Figure 13.1 on page 13-1](#)).

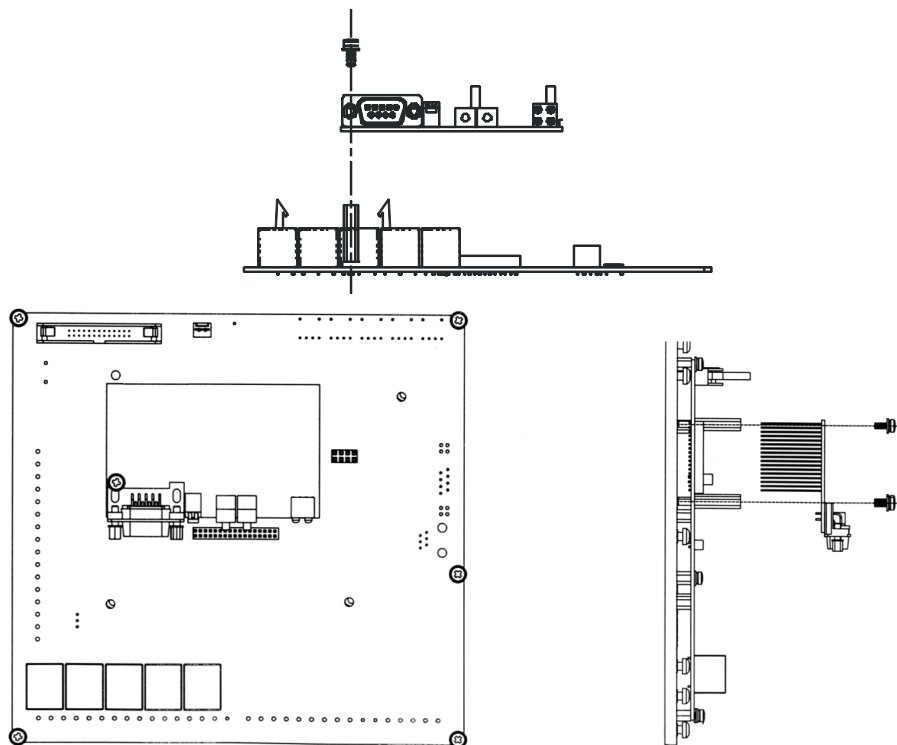

Figure 13.1: Fieldbus electronic board installation

4. Press the board close to XC140 and on the bottom right corner until the complete insertion of the connector and the plastic spacer.

5. Secure the board to the metallic spacers with the provided bolt.
6. Connect one end of the Fieldbus cable to the MVW-01 control rack, according to the [Figure 13.3 on page 13-2](#).
7. Connect the other end of the Fieldbus cable to the Fieldbus board, according to the [Figure 13.3 on page 13-2](#).

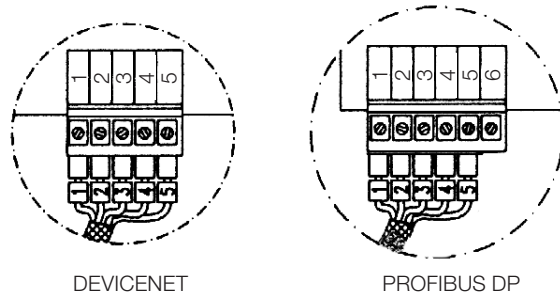

Figure 13.2: Connection to the Fieldbus board

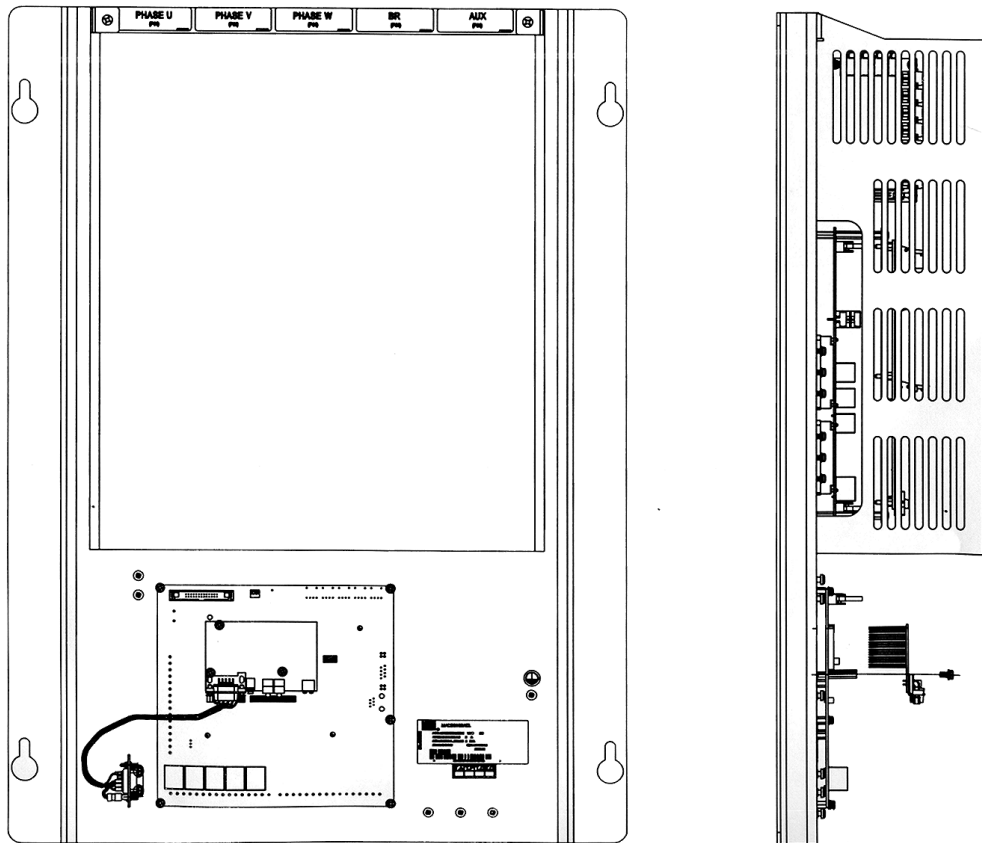

Figure 13.3: Connection to the Fieldbus board

13.1.2 Profibus DP

The inverter that is fitted with the Profibus DP Kit operates in slave mode, allowing the reading/writing of its parameters through a master. The inverter does not start the communication with other nodes, it only answers to the master controls. The physical medium uses a two-conductor twisted-pair cable (RS-485) allowing data transmission at baud rates between 9.6 kbits/s and 12 Mbits/s. The following figure shows an overview of a Profibus DP network.

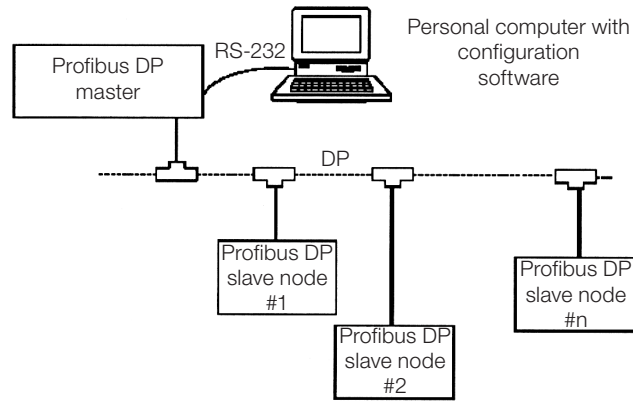

Figure 13.4: Profibus DP network

- Fieldbus Type: Profibus DP EN 50170 (DIN 19245).

Physical Interface

- Transmission medium: Profibus busbar line, type A or B as specified in EN50170.
- Topology: Master-Slave communication.
- Insulation: the bus is fed by a DC/DC converter, which is galvanically isolated from the remaining electronics, and the signals A and B are isolated by means of optocouplers.
- It allows the connection/disconnection of a node without affecting the network.

Inverter user Fieldbus connector.

Connector: D-sub 9 pins - female, pinout according to the next table.

Table 13.1: Profibus DP DB9 pinout

Pin	Name	Function
1	Not connected	-
2	Not connected	-
3	B-Line	RxD/TxD positive, according to the RS-485 specification
4	Not connected	-
5	GND	0 V isolated from the RS-485 circuit
6	+5 V	+5 V isolated from the RS-485 circuit
7	Not connected	-
8	A-Line	RxD/TxD negative, according to the RS-485 specification
9	Not connected	-
Frame	Shield	Connected to the protective ground (PE)

Line Termination

The initial and the end points of the network must present the characteristic impedance, in order to prevent reflections. The DB9 cable male connector has the suitable termination resistor. When the inverter is the first or the last of the network, the termination resistor switch must be set to "ON". Otherwise, leave the switch in the "OFF" position. The terminating switch of the Profibus DP board must be set to 1 (OFF).

Baud rate

The baud rate of a Profibus DP network is defined during the master configuration and only one rate is allowed in the same network. The Profibus DP board has automatic baud rate detection and the user does not need to configure it on the board. The supported baud rates are 9.6 kbits/s, 19.2 kbits/s, 45.45 kbits/s, 93.75 kbits/s, 187.5 kbits/s, 500 kbits/s, 1.5 Mbits/s, 3 Mbits/s, 6 Mbits/s and 12 Mbits/s.

Node Address

The node address is established by means of two rotating switches on the electronic Profibus DP board, allowing the addressing from 1 to 99. Looking at the board with the inverter in normal position, the leftmost switch sets the

ten of the address, while the rightmost switch sets the units of the address:

$$\text{Address} = (\text{leftmost rotary switch} \times 10) + (\text{rightmost rotary switch} \times 1)$$

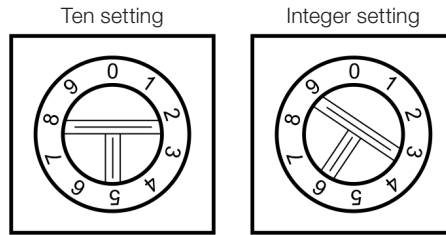

Figure 13.5: Node address

NOTE! The node address must not be changed with the network in operation.

Configuration File (GSD File)

Each element of a Profibus DP network is associated to a GSD file that has all information about the element operation. This file is supplied together with the product and is used by the network configuration program.

Signaling

The electronic board has a bicolor LED indicating the status of the Fieldbus according to the [Table 13.2 on page 13-4](#).

Table 13.2: Fieldbus status LED signaling

LED Color	Frequency	Status
Red	2 Hz	Fault during the test of the ASIC and Flash ROM
Green	2 Hz	Board has not been initialized
Green	1 Hz	Board has been initialized and is operating
Red	1 Hz	Fault during the RAM test
Red	4 Hz	Fault during the DPRAM test

NOTE! The red signalizations may indicate hardware problems on the electronic board. Its reset is performed by cycling the power of the inverter. If the problem persists, replace the electronic board.

The board also has other four LEDs grouped at the right bottom corner, indicating the Fieldbus network status do Fieldbus according to [Figure 13.6 on page 13-4](#) and [Table 13.3 on page 13-5](#) below.

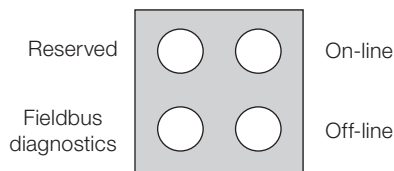

Figure 13.6: LEDs indicating the status of the Profibus DP network

Table 13.3: Profibus DP network status LEDs

LED	Color	Function
Fieldbus diagnostics	Red	It indicates the following faults on the Fieldbus side: Flashing 1 Hz - Configuration error: the IN/OUT area size set at board initialization is different from the size set during the network configuration. Flashing 2 Hz - Error in the user parameter data: the size/content of the user parameter data set at board initialization is different from the size/content set during the network configuration. Flashing 4 Hz - Profibus Communication ASIC initialization error. OFF - No present problems.
On-line	Green	Indicates that the board is on-line in Fieldbus network: ON - The board is on-line and the data exchange is possible. OFF - The board is not on-line.
Off-line	Red	Indicates that the board is off-line in Fieldbus network: ON - The board is off-line and the data exchange is not possible. OFF - The board is not off-line.

NOTE!

- When power is applied to the drive and both on-line and off-line LEDs on the Profibus DP board flash alternately, then a network address configuration or an installation problem may be present.
- Check the installation and the network node address.
- Refer to the [Item 13.1.6 Fieldbus Application/MVW-01 Related Parameters on page 13-7](#), for DeviceNet application/MVW-01 related parameters.

13.1.3 DeviceNet

The DeviceNet communication is used for industrial automation, mainly for the control of valves, sensors, input/output units and automation equipment. The DeviceNet communication link is based on a communication protocol “broadcast oriented”, the Controller Area Network (CAN). The physical medium of the DeviceNet network consists of a shielded cable comprising a twisted pair and two wires for the external power supply. The baud rate can be set to 125 kbits/s, 250 kbits/s or 500 kbits/s. The [Figure 13.7 on page 13-5](#) for Profibus DP application/MVW-01 related parameters.

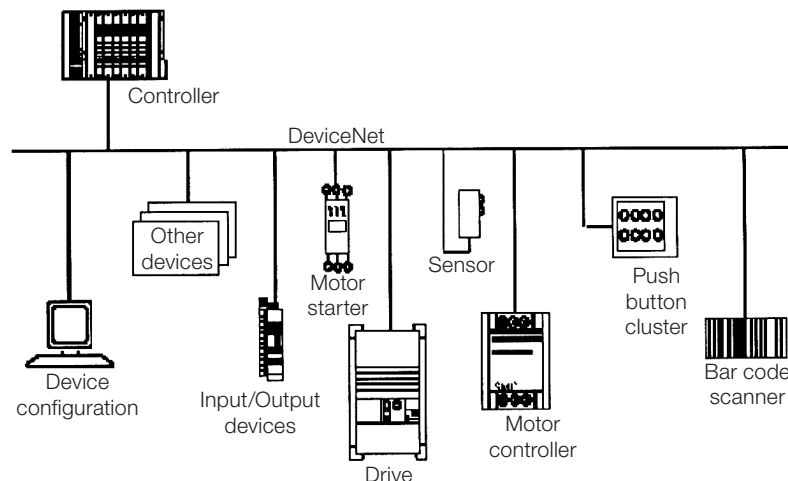
Figure 13.7: DeviceNet network

Inverter user Fieldbus connector.

5 pin plug-in terminal block (screw terminal), pinout according to the next table.

Table 13.4: DeviceNet terminal block pinout

Terminal	Description	Color
1	V-	Black
2	CAN_L	Blue
3	Cable shield	-
4	CAN_H	White
5	V+	Red

Line Termination

The initial and the end points of the network must present the characteristic impedance, in order to prevent reflections. Thus a 121 Ω/0.5 W resistor must be connected between the terminals 2 and 4 of the Fieldbus terminal block.

Baudrate/Node Address

There are three different baudrates for DeviceNet: 125 kbits/s, 250 kbits/s and 500 kbits/s. Choose the baudrate by setting the DIP switches on the electronic board, before the network configuration. The node address is selected through the six DIP switches on the electronic board, permitting addressing from 0 to 63.

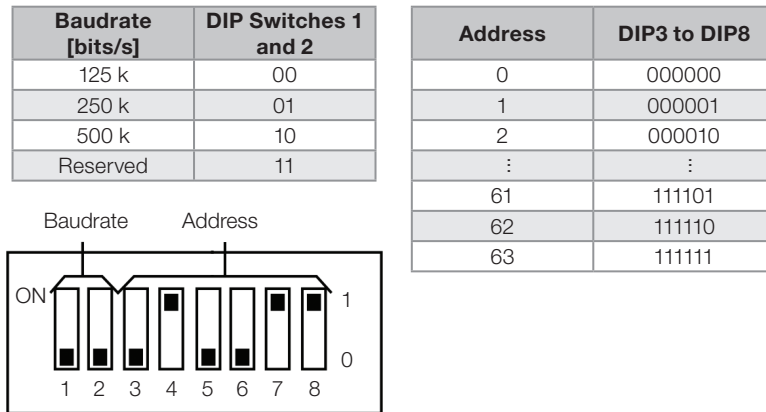

Figure 13.8: DeviceNet baudrate and node address configuration

Configuration File (EDS File)

Each element of a DeviceNet network is associated to an EDS file, which has all information about the element. This file is supplied together with the product and is used by the network configuration program.

By means of the parameter P309 it is possible to select 2, 4 or 6 input/output words, when P309 is programmed 4, 5 or 6, respectively (refer to the [Item 13.1.6 Fieldbus Application/MVW-01 Related Parameters on page 13-7](#)). Define in the network configuration program the number of exchanged words, according to the number selected at the parameter P309. The type of connection used for data exchange must be "Polled I/O".

NOTE!
The PLC (master) must be programmed for Polled I/O connection.

Signaling

The electronic board has a bicolor LED indicating the status of the Fieldbus according to the [Table 13.2 on page 13-4](#).

NOTE!
The red signalizations may indicate hardware problems on the electronic board. Its reset is performed by cycling the power of the inverter. If the problem persists, replace the electronic board.

The board also has other four LEDs grouped at the right bottom corner, indicating the Fieldbus network status according to [Figure 13.9 on page 13-6](#) and [Table 13.5 on page 13-7](#) below.

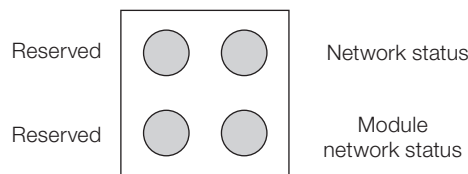

Figure 13.9: LEDs indicating the status of the DeviceNet network

Table 13.5: DeviceNet network status LEDs

LED	Color	Description
Module Network Status	Off	Without supply
Module Network Status	Red	Nonrecoverable fault
Module Network Status	Green	Operational board
Module Network Status	Flashing red	Minor fault
Network Status	Off	Without supply/off-line
Network Status	Green	Operative link, connected
Network Status	Red	Link critical fault
Network Status	Flashing green	On-line, not connected
Network Status	Flashing red	Connection timeout

NOTE!

- Refer to the [Item 13.1.6 Fieldbus Application/MVW-01 Related Parameters on page 13-7](#) for DeviceNet application/MVW-01 related parameters.
- The company HMS Industrial Networks AB has developed the communication board that comes with the product. Therefore, the network configuration software will not recognize the product as the MVW-01 frequency inverter, but as the "Anybus-S DeviceNet" at the "Communications Adapter" category. The differentiation will be done using the device network address, adjusted according to the [Figure 13.9 on page 13-6](#) and the [Table 13.5 on page 13-7](#).

13.1.4 DeviceNet Drive Profile

NOTE!

Refer to the DeviceNet Drive Profiles manual.

13.1.5 Ethernet

NOTE!

Refer to the Ethernet SSW-06 manual.

13.1.6 Fieldbus Application/MVW-01 Related Parameters

There are two main parameters: P309 and P313.

P309 - defines the used Fieldbus protocol (Profibus DP or DeviceNet) and the number of variables (I/O) exchanged with the master (2, 4 or 6). The parameter P309 has the following options:

- | | |
|---|-------------------------------|
| 0 = Inactive. | 7 = Modbus-RTU 2 I/O. |
| 1 = Profibus DP 2 I/O. | 8 = Modbus-RTU 4 I/O. |
| 2 = Profibus DP 4 I/O. | 9 = Modbus-RTU 6 I/O. |
| 3 = Profibus DP 6 I/O, (for Profibus DP). | 10 = Devicenet Drive Profile. |
| 4 = DeviceNet 2 I/O. | 11 = Ethernet IP 2 I/O. |
| 5 = DeviceNet 4 I/O. | 12 = Ethernet IP 4 I/O. |
| 6 = DeviceNet 6 I/O, (for DeviceNet). | 13 = Ethernet IP 6 I/O. |

NOTE!

The alarms A129/A130 are presented on the conventional HMI as E29/E30.

P313 - defines the inverter behavior when the physical connection with the master is interrupted and/or the Fieldbus board is inactive (A128, A129 or A130 indicated on the display).

The parameter P313 has the following options:

- 0 = disables the inverter by using the Start/Stop controls via deceleration ramp.
- 1 = disables the inverter by using the General Enabling, motor coasting.

- 2 = the inverter status is not changed.
- 3 = the inverter goes to Local mode.

13.1.6.1 Variables Read From the Inverter

1. Status word.
2. Motor speed, for the option P309 = 1 or 4 (2I/O) - read 1 and 2.
3. Digital input status (P012).
4. Parameter contents, for the option P309 = 2 or 5 (4I/O) - read 1, 2, 3 and 4.
5. Parameter contents, for the option (P009).
6. Motor current (P003), for the option P309 = 3 or 6 (6I/O) - read 1, 2, 3, 4, 5 and 6.

1. Status word (EL):

The status word is composed by a total of 16 bits, 8 high order bits and 8 low order bits. It has the following construction:

High-order bits - they indicate the status of the associated function.

- EL.15 - Active error: 0 = No, 1 = Yes.
- EL.14 - PID Regulator: 0 = Manual, 1 = Automatic.
- EL.13 - Undervoltage of the electronics power supplies: 0 = Without, 1 = With.
- EL.12 - Local/Remote command: 0 = Local, 1 = Remote.
- EL.11 - JOG command: 0 = Inactive, 1 = Active.
- EL.10 - Forward/Reverse: 0 = Reverse, 1 = Forward.
- EL.09 - General enabling: 0 = Disabled, 1 = Enabled.
- EL.08 - Start/Stop: 0 = Stop, 1 = Start.

(*) EL.08 = 1 means the inverter received the Run/Stop command via networks. This EL is not intended to signal that the motor is effectively spinning.

Low-order bits -they indicate the error code number, i.e., 03, 07 or 87 (57h).

Refer to the [Section 14.1 ALARMS/FAULTS AND POSSIBLE CAUSES on page 14-1](#).

2. Motor speed:

This variable is shown by using 13-bit resolution plus signal. Thus, the rated value will be equal to 8191 (1FFFh) (Forward) or -8191 (E001h) (Reverse) when the motor is running at synchronous speed (or base speed, for instance 1800 rpm for a IV-pole motor, 60 Hz).

3. Digital input status:

It presents the parameter P012 contents, where 1 indicates an active input and 0 indicates an inactive input. Refer to the [Section 11.1 ACCESS AND READ ONLY PARAMETERS - P000 to P099 on page 11-1](#). The digital inputs are distributed in the manner in this WORD:

- Bit.7 - DI1 status.
- Bit.6 - DI2 status.
- Bit.5 - DI3 status.
- Bit.4 - DI4 status.
- Bit.3 - DI5 status.
- Bit.2 - DI6 status.
- Bit.1 - DI7 status.
- Bit.0 - DI8 status.
- Bit.8 - DI9 status.
- Bit.9 - DI10 status.

4. Parameter contents:

This position allows reading the contents of inverter parameters, which are selected at the position 4 - Number of the parameters to be read - of the variables written in the inverter. The read values have the same order of magnitude of those described in the product manual or showed on the HMI.

The values are read without the decimal point, if that is the case. Examples:

- a) HMI displays 12.3, the Fieldbus reading will be 123.
- b) HMI displays 0.246, the Fieldbus reading will be 246.

There are some parameters whose representation on the LED display can suppress the decimal position when the values are higher than 99.9. These parameters are P100, P101, P102, P103, P155, P156, P157, P158, P169 (for P202 < 3), P290 and P401.

Example: Indication on the LED display: 130.
Indication on the LCD : 130.0, Fieldbus reading is: 1300.

The reading of the parameter P006 via Fieldbus has the meaning presented in the detailed parameter description - [Chapter 11 DETAILED PARAMETER DESCRIPTION on page 11-1](#).

5. Torque current:

This position indicates P009 parameter contents, without the decimal point. A low pass filter with a time constant of 0.5 s filters this variable.

6. Motor current:

This position indicates P003 parameter contents, without the decimal point. A low pass filter with a time constant of 0.3 s filters this variable.

13.1.6.2 Variables Written in Inverter

The variables are written in the following order:

1. Control Word.
2. Motor speed reference, for the option P309 = 1 or 4 (2I/O) - it writes in 1 and 2.
3. Status of the digital outputs.
4. Number of the parameters to be read, for the option P309 = 2 or 5 (4I/O) - it writes in 1, 2, 3 and 4.
5. Number of the parameter to be changed.
6. Content of the parameter to be changed, selected in the previous position, for the option P309 = 3 or 6 (6I/O) - it writes in 1, 2, 3, 4, 5 and 6.

1. Control word (C.L.):

The control word is composed by a total of 16 bits, 8 high order bits and 8 low order bits. It has the following construction:

High-order bits - they select the functions to be controlled, when the correspondent bits are set to 1.

CL.15 - Inverter fault reset.

CL.14 - Without function.

CL.13 - To save the changes of parameters P169/P170 in the EEPROM.

CL.12 - Local/Remote command.

CL.11 - Jog command.

CL.10 - Forward/Reverse.

CL.09 - General Enabling.

CL.08 - Start/Stop.

Low-order bits - they determine the activation of the functions selected in the high-order bits,

CL.7 - Inverter fault reset: every time it changes from 0 to 1 it causes an inverter reset, except for the errors (except A124, A125, A126 and A127);

CL.6 - No function.

CL.5 - To save P169/P170 in the EEPROM: 0 = to save, 1 = not to save.

CL.4 - Local/Remote command: 0 = Local, 1 = Remote.

CL.3 - Jog command: 0 = Inactive, 1 = Active.

CL.2 - Forward/Reverse: 0 = Reverse, 1 = Forward.

CL.1 - General enabling: 0 = Disabled, 1 = Enabled.

CL.0 - Start/Stop: 0 = Stop, 1 = Start.



NOTE!

- The inverter will only execute the command defined in the low-order bit if the correspondent high-order bit is set to 1 (one). If the high-order bit is set to 0 (zero), the inverter will disregard the value of the correspondent low-order bit.
- CL.13: The function of saving parameter content changes in the EEPROM occurs normally when the HMI is used. The EEPROM allows a limited number of writings (100.000). In applications in which the speed regulator remains saturated and torque control is required, this control can be achieved by adjusting the torque limits P169/P170 (valid for P202 > 2). Therefore, if the network master keeps writing continuously in P169/P170, then the correspondent bits must be programmed in order to avoid that every change be saved in the EEPROM by setting: CL.13 = 1 and CL.5 = 1.

In order to enable the functions of the Control Word, it is necessary to set the inverter respective parameters with the option "Fieldbus".

- a) Local/Remote Selection Source - P220.
- b) Speed Reference - P221 and/or P222.
- c) Forward/Reverse Selection - P223 and/or P226.
- d) General Enabling, Start/Stop Selection - P224 and/or P227.
- e) JOG Selection - P225 and/or P228.

2. Motor speed reference:

This variable is presented using a 13 bit resolution. Therefore, the speed reference value for the motor synchronous speed will be equal to 8191 (1FFFh).

This value must be used only as the base speed for the calculation of the desired speed (speed reference).

Examples:

- 1. 4-pole, 60 Hz motor, synchronous speed = 1800 rpm and speed reference = 650 rpm.

$$\begin{array}{r} 1800 \text{ rpm} - 8191 \\ 650 \text{ rpm} - X \end{array} \longrightarrow X = 2958 = 0B8Eh$$

This value (0B8Eh) must be written in the second word, which represents the motor speed reference (according to the beginning of this item.).

- 2. 6-pole, 60 Hz motor, synchronous speed = 1200 rpm and speed reference = 1000 rpm.

$$\begin{array}{r} 1200 \text{ rpm} - 8191 \\ 1000 \text{ rpm} - X \end{array} \longrightarrow X = 4096 = 1AAAh$$

This value (1AAAh) must be written in the second word, which represents the motor speed reference (according to the beginning of this item).



NOTE!

Values above 8191 (1FFFh) are allowed when speed references above the motor synchronous speed are required, as long as the maximum programmed speed reference is respected.

3. Status of the digital outputs:

It allows controlling the status of the digital outputs that have been programmed for Fieldbus at the parameters P275 to P282. 16 bits, with the following construction, form the word that defines the status of the digital outputs:

High-order bits: they define the outputs to be controlled, when set in 1.

Bit.08: 1 - DO1 output control.

Bit.09: 1 - DO2 output control.

Bit.10: 1 - RL1 output control.

Bit.11: 1 - RL2 output control.

Bit.12: 1 - RL3 output control.

Low-order bits: they define the status of the controlled outputs.

Bit.0 - DO1 status: 0 = inactive output, 1 = active output.

Bit.1 - DO2 status: idem.

Bit.2 - RL1 status: idem.

Bit.3 - RL2 status: idem.

Bit.4 - RL3 status: idem.

4. Number of the parameters to be read:

Through this position, the reading of any inverter parameter can be defined. The number of the parameter to be read must be programmed here, and its contents will be presented at the position 4 of the variables read from the inverter.

5. Number of the parameter to be changed: (parameter contents modification).

This position operates together with the position 6, described next.

When no parameter has to be changed, then fill this position with the code 999.

Changing process sequence:

- Keep 999 in the position 5.
- Replace 999 by the number of the parameter to be changed.
- If no error code (124 to 127) is signaled in the Status Word, then replace the parameter number by 999, in order to conclude the modification.

The modification can be verified via the HMI or by reading the parameter contents.



NOTE!

1. The command to pass from V/F to vector control will not be accepted if any of the parameters from P409 to P413 remains set to zero. In such case, this command must be done via HMI.
2. Do not program P204 = 5, because in the factory default settings P309 = Inactive.
3. P204 and P408 do not accept modification via network command.
4. The parameter contents must be kept by the master during 15.0 ms. Send a new value or write in another parameter only after this time has elapsed.

6. Content of the parameter to be changed, selected at the position 5: (Number of the parameter to be changed)
 The format of the values adjusted in this position must be the ones described in the manual. The values, however, must be written without the decimal point, if this is the case. When the parameters P409 to P413 are modified, small differences in the contents may occur when comparing the value sent via Fieldbus and the value read at the position 4. (Parameter contents) or at the HMI, because of the truncating during the reading process.

13.1.6.3 Error Indications

During the Fieldbus reading/writing process the following error indications may occur and be informed at the Status Word variable:

Status Word variable indications:

- A124 - An attempt to change a parameter that can be modified only with disabled inverter.
 - Parameterization error.
- A125 - Caused by:
 - Reading of non-existent parameter, or
 - Writing on non-existent parameter, or
 - Writing on P408 and P204.
- A126 - An attempt to write a value out of the permitted range.
- A127 - Caused by:
 a) A function selected by the Control Word has not been programmed for Fieldbus, or
 b) Command of a digital output that has not been programmed for Fieldbus, or
 c) An attempt to write in a read-only parameter.

The indication of the listed errors will be removed from the Status Word when the indented action is sent correctly, except for A127 (“b” case), whose reset is performed writing in the Control Word.

Example: Assuming that no digital output has been programmed for Fieldbus, then if the word 11h is written in the position 3, the inverter will respond indicating A127 in the Status Word. To remove this indication from the Status Word it is necessary:

1. To write zero in the position 3 (because no DO has been programmed for Fieldbus).
2. To change the Control Word variable so that the A127 indication be removed from the Status Word.

The removal of the listed errors from the Status Word can also be achieved by writing the 999 code in the position 5 of the variables written in the inverter. Except for A127 (“b” and “a” cases), whose reset occurs only through the writing in the Control Word, as exemplified above.



NOTE!

The alarms A124, A125, A126 and A127 do not cause any change in the inverter operation status.

HMI Indications:

E29 - Inactive Fieldbus Connection

This indication occurs when the physical connection from the inverter to the master is interrupted. The action that the inverter will take when E29 is detected is programmed at P313. The E29 indication is removed from the display when the HMI key is pressed.

E30 - Inactive Fieldbus Board.

This indication will appear when:

1. P309 is programmed different from Inactive, without the existence of the respective board mounted on the MVC4 board XC140 connector, or
2. The Fieldbus board exists but it is defective, or
3. The board exists; however, the model programmed in P309 does not match the used board model.
The action that the inverter will take when E30 is detected is programmed at P313. The E30 indication is removed from the display when the HMI key is pressed.

13.1.6.4 MVW-01 Variable Addressing at the Fieldbus Devices

The variables are arranged in the Fieldbus device memory from 00h on, for both writing and reading. What deals with the address differences is the protocol itself, and the communication board. The manner the variables are arranged in each address of the Fieldbus device memory depends on the equipment that is being used as master. In an A PLC, for instance, the variables are arranged High and Low, whereas in a B PLC the variables are arranged Low and High.

13.2 WEGBUS SERIAL

The basic purpose of the serial communication is the physical connection of the inverters in an equipment network configured in the following form:

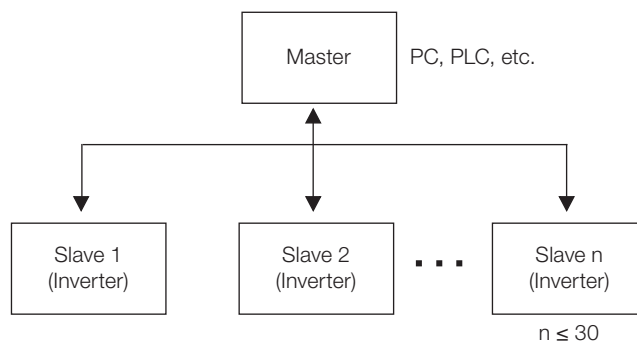

Figure 13.10: Serial configuration

The inverters have a software for the interface data transmission/reception control, to make it possible the receiving of data sent by the master as well as the transmission of data requested by it. The baudrate is 9600 bits/s, following an exchange protocol of the request/response type, using ASCII characters.

The master will have the means to do the following operations regarding each inverter:

IDENTIFICATION

- Network address.
- Inverter type (model).
- Software version.

COMMAND

- General enabling/disabling.
- Enable/Disable by ramp (Run/Stop).
- Speed direction.
- Speed reference.
- Local/Remote.
- JOG.
- Fault RESET.

STATUS ACKNOWLEDGMENT

- Ready.
- Sub.
- Run.
- Local/Remote.
- Fault.
- JOG.
- Speed direction.
- Setting mode after the reset to the factory default.
- Setting mode after changing from V/F mode to Vector mode.

PARAMETER READING

PARAMETER MODIFICATION

Typical examples of network use:

- PC (master) for parameterization of one or several inverters at the same time.
- SDCD monitoring inverter variables.
- PLC controlling the operation of an inverter in an industrial process.

Description of the Interfaces

The physical connection between the inverters and the network master is performed according to one of the standards below:

- a) RS-232 (point-to-point, up to 10 m).
- b) RS-485 (multipoint, galvanic isolation, up to 1000 m).

RS-485

This interface allows the connection of up to 30 inverters to a master (PC, PLC, etc.), attributing to each inverter an address (1 to 30) that must be set at each one. In addition to these 30 addresses, there are two other addresses available to perform special tasks:

Address 0: any inverter in the network is inquired, regardless of its address. Only one inverter must be connected to the network (point-to-point) in order to prevent short-circuits in the interface lines.

Address 31: um command can be transmitted simultaneously to all the inverters in the network, without acceptance acknowledgment.

List of the addresses and the correspondent ASCII characters:

Table 13.6: ASCII characters

ADDRESS (P308)	ASCII		
	CHAR	DEC	HEX
0	@	64	40
1	A	65	41
2	B	66	42
3	C	67	43
4	D	68	44
5	E	69	45
6	F	70	46
7	G	71	47
8	H	72	48
9	I	73	49
10	J	74	4A
11	K	75	4B
12	L	76	4C
13	M	77	4D
14	N	78	4E
15	O	79	4F
16	P	80	50
17	Q	81	51
18	R	82	52
19	S	83	53
20	T	84	54
21	U	85	55
22	V	86	56
23	W	87	57
24	X	88	58
25	Y	89	59
26	Z	90	5A
27]	91	5B
28	\	92	5C
29	[93	5D
30	^	94	5E
31	_	95	5F

Other ASCII characters used by the protocol:

Table 13.7: ASCII characters used in protocol

CODE	ASCII	
	DEC	HEX
0	48	30
1	49	31
2	50	32
3	51	33
4	52	34
5	53	35
6	54	36
7	55	37
8	56	38
9	57	39
=	61	3D
STX	02	02
ETX	03	03
EOT	04	04
ENQ	05	05
ACK	06	06
NAK	21	15

The connection between the network nodes is performed through a pair of wires. The signal levels are according to RS-485 EIA STANDARD, with differential receivers and transmitters. Expansion boards EBA.01, EBA.02 or EBB.01 (refer to [Item 10.2.1 EBA \(I/O Expansion Board A\)](#) on page 10-5 and the [Item 10.2.2 EBB \(I/O Expansion Board B\)](#) on page 10-8).

When the master does only have a RS-232 interface, then a RS232/RS485 converter must be used.

RS-232

With the RS-232 interface the connection of one master to one slave is possible (point-to-point). Data can be exchanged in a bidirectional way, but not simultaneously (HALF DUPLEX).

The logic levels follow the RS-232 EIA STANDARD, which determines the use of unbalanced signaling. In the present case, one wire is used for transmission (TX), other for reception (RX) and another for ground (0 V). This configuration is the minimal “3-wire” RS-232 connection (3-wire economy model).

Note: refer to the [Item 13.2.4 RS-232 and RS-485 Physical Connection](#) on page 13-22 which describes the physical connection.

13.2.1 Protocol Definitions

Used Terms

- Parameters: Are those existent in the inverter, whose visualization or modification is possible through the HMI.
- Variables: are values with specific functions in the inverter and can be read and, in some cases, modified by the master.
- Basic Variables: Are those that can only be accessed through the serial communication.

Diagram:

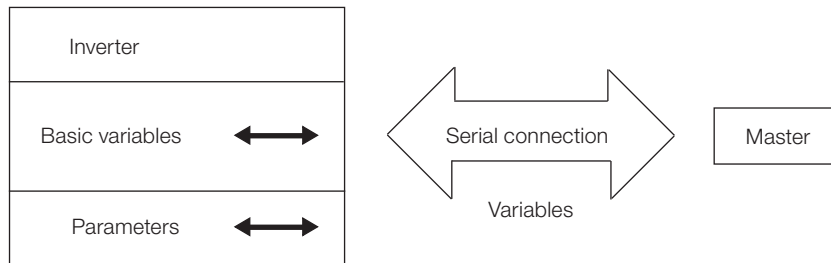

Figure 13.11: Scheme of basic variables

Parameter/Variable Resolutions

During parameter reading/writing their decimal points are disregarded in the values received/sent via telegrams, whereas the basic variables V04 (Serial Reference) and V08 (Motor Speed) that are standardized as 13 bit (0 to 8191).

Examples:

- Writing: If the purpose is to change the P100 content to 10.0 s, 100 must be sent (disregarding the decimal point).
- Reading: If 1387 (disregarding the decimal point) is read from P409, then its value is 1.387.
- Writing: in order to change V04 content to 900 rpm one must send:

$$V04 = \frac{900 \times 8191}{P208} = 4096$$

Assuming that P208 = 1800 rpm

- Reading: If 1242 is read from V08, the corresponding value is given by:

$$V08 = \frac{1242 \times P208}{8191} = 273 \text{ rpm}$$

Assuming that P208 = 1800 rpm

Character Format

- 1 start bit.
- 8 data bits (they codify text and transmission characters, taken from the 7-bit code, according to ISO 646 and complemented for even parity [eighth bit]).
- 1 stop bit.

After the start bit goes the least significant bit:

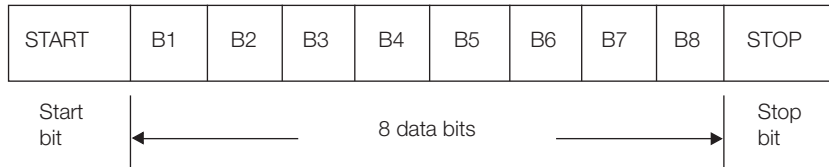

13.2.2 Variable Code

V00 (code 00800):

Inverter model indication (reading variable).

The reading of this variable allows identifying the inverter type. For the MVW-01, this value is 8, as follows:

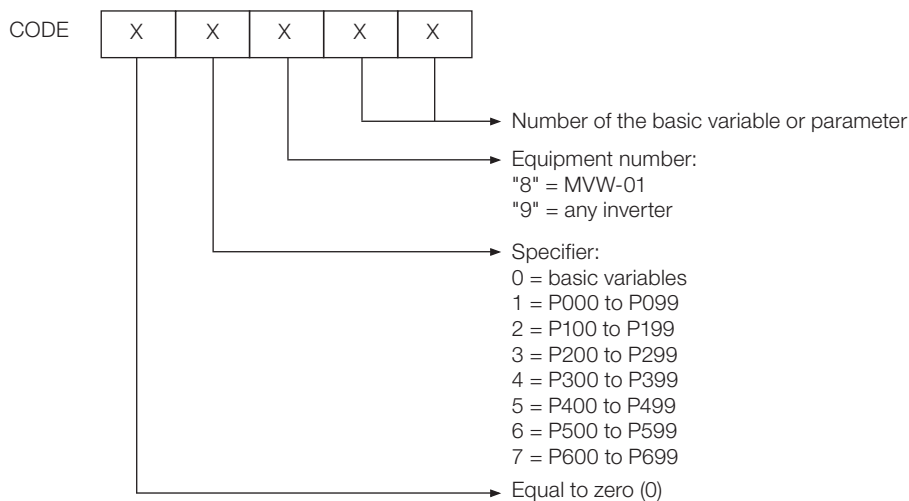

V02 (code 00802):

Inverter status indication (reading variable).

- Status word (byte-high).
- Error code (byte-low).

Where:

Status Word:

EL15	EL14	EL13	EL12	EL11	EL10	EL9	EL8
------	------	------	------	------	------	-----	-----

- EL8: 0 = Enable by ramp (run/stop) inactive / 1 = Enable by ramp active.
- EL9: 0 = General enable inactive / 1 = General enable active.
- EL10: 0 = Reverse / 1 = Forward.
- EL11: 0 = JOG inactive / 1 = JOG active.

- EL12: 0 = Local / 1 = Remote.
- EL13: 0 = Without undervoltage / 1 = With undervoltage.
- EL14: 0 = Manual (PID) / 1 = Automatic (PID).
- EL15: 0 = Without fault / 1 = With fault.

Error code: error number in hexadecimal format.

Examples:

F001 → 01h

F087 → 57h

V03 (code 00803):

Selection of logical command.

Writing variable, whose bits have the following meaning:

High-order bits: desired action mask. In order that the action be possible, the correspondent bit must be set in 1.

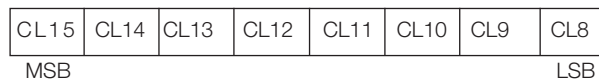

- CL8: 1 = Enable ramp (run/stop).
- CL9: 1 = General Enable.
- CL10: 1 = Forward/Reverse.
- CL11: 1 = JOG.
- CL12: 1 = Local/Remote.
- CL13: Not used.
- CL14: Not used.
- CL15: 1 = Inverter "RESET".

Low-order bit: logic level of the desired action.

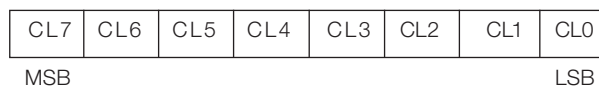

- CL0: 1 = Enable (run) / 0 = Disable by ramp (stop).
- CL1: 1 = Enable / 0 = General disable (stop by inertia).
- CL2: 1 = Forward / 0 = Reverse.
- CL3: 1 = JOG active / 0 = JOG inactive.
- CL4: 1 = Remote / 0 = Local.
- CL5: Not used.
- CL6: Not used.
- CL7: Transition from 0 to 1 in this bit "RESETS" the inverter in case it is in some fault condition.



NOTE!

- A disable command via digital input has higher priority than the Control Word enabling.
- In order to enable the inverter it is necessary that CL0 = CL1 = 1, and that there is no external disabling command.
- If CL0 and CL1 are set to 0 simultaneously, than general disable occurs.

V04 (code 00804):

Serial speed reference (reading/writing variable).

It allows sending the speed reference to the inverter, as long as P221 = 9 for Local situation, or P222 = 9 for Remote situation. This variable has a 13 bit resolution (refer to the [Item 13.2.1 Protocol Definitions on page 13-15](#)).

V06 (code 00806):

Status of the operation modes (reading variable).

EL2 7	EL2 6	EL2 5	EL2 4	EL2 3	EL2 2	EL2 1	EL2 0
MSB				LSB			

- EL2.0: 1 = during the Guided Start-up Routine after a reset to the factory default/first power-up.
- The inverter will enter this operation mode when it is powered-up for the first time or when the factory default parameters are loaded (P204 = 5 or 6). In this mode only the parameters P023, P201, P295, P296, P400, P401, P402, P403, P404 and P406 will be accessible. If an attempt to access another parameter is done, the inverter will respond with A125. In order to get more details, refer to the [Item 8.3.2 Initial Power-up \(Parameter Settings\) on page 8-18](#).
- EL2.1: 1 = during the adjusting mode after changing from V/F to Vector Mode.
- The inverter will enter this operation mode when the control mode is changed from V/F (P202 = 0, 1 or 2) to Vector (P202 = 3 or 4). In this mode only the parameters P023, P201, P295, P296, P400, P401, P402, P403, P404 and P406 will be accessible. If an attempt to access another parameter is done, the inverter will respond with A125.
- EL2.2: 1 = performing the self-tuning.
- EL2.3: not used.
- EL2.4: not used.
- EL2.5: not used.
- EL2.6: not used.
- EL2.7: not used.

V07 (code 00807):

Status of the operation modes (reading/writing variable).

CL2 7	CL2 6	CL2 5	CL2 4	CL2 3	CL2 2	CL2 1	CL2 0
MSB				LSB			

- CL2.0: 1 - it leaves the Guided Start-up Routine after a reset to the factory default.
- CL2.1: 1 - it leaves the adjusting mode after changing from V/F to Vector Mode.
- CL2.2: 1 - it aborts the self-tuning.

- CL2.3: 1 - not used.
- CL2.4: 1 - not used.
- CL2.5: 1 - not used.
- CL2.6: 1 - not used.
- CL2.7: 1 - not used.

V08 (code 00808):

Motor Speed in 13 bit resolution (reading variable).

It allows reading the motor speed with a 13 bit resolution (refer to the [Item 13.2.1 Protocol Definitions on page 13-15](#)).

V09 (code 00809). Reading:

b0: 1 - reversing SG (Forward/Reverse).

b1: 1 - active alarm.

VB 12 (code 005012). Status of the Digital Outputs:

It allows controlling the status of the digital outputs that have been programmed for Serial at the parameters P275 to P280.

16 bits, with the following construction, form the word that defines the status of the digital outputs:

High-order bits: they define the outputs to be controlled, when set in 1.

Bit.08: 1 - DO1 output control.

Bit.09: 1 - DO2 output control.

Bit.10: 1 - RL1 output control.

Bit.11: 1 - RL2 output control.

Bit.12: 1 - RL3 output control.

Bit.13: 1 - RL4 output control.

Bit.14: 1 - RL5 output control.

Low-order bits: they define the status of the controlled outputs.

Bit.0: - DO1 status: 0 = inactive output, 1 = active output.

Bit.1: - DO2 status: 0 = inactive output, 1 = active output.

Bit.2: - RL1 status: 0 = inactive output, 1 = active output.

Bit.3: - RL2 status: 0 = inactive output, 1 = active output.

Bit.4: - RL3 status: 0 = inactive output, 1 = active output.

Bit.5: - RL4 status: 0 = inactive output, 1 = active output.

Bit.6: - RL5 status: 0 = inactive output, 1 = active output.

Parameters Related to the Serial Communication

Table 13.8: Parameters Related to the Serial Communication

Parameter Nr.	Parameter Description
P220	Local/Remote Selection Source
P221	Speed Reference Selection - Local Situation
P222	Speed Reference Selection - Remote Situation
P223	Forward/Reverse Selection - Local Situation
P224	Start/Stop Selection - Local Situation
P225	JOG Selection - Local Situation
P226	Forward/Reverse Selection - Remote Situation
P227	Start/Stop Selection - Remote Situation
P228	JOG Selection - Remote Situation
P308	Inverter address in the serial communication network (range from: 1 to 30)

In order to get more details on the parameters above, refer to the [Chapter 11 DETAILED PARAMETER DESCRIPTION on page 11-1](#).

Errors Related to the Serial Communication

They operate in the following way:

- They do not disable the inverter.
- They do not commutate fault relays.
- They are reported in the Status Word (V02).

Type of errors:

- A122: longitudinal parity error (BCC).
- A124: parameterization error (occurrence of some of the situations indicated in the [Table 9.5 on page 9-10](#) or when there is an attempt to change a parameter that cannot be changed with a rotating motor).
- A125: nonexistent variable or parameter.
- A126: value out of the range.
- A127: an attempt to write in a read-only variable or a disabled control word command.



NOTE!

- If in the inverter data reception a parity error is detected, then the telegram is ignored. The same will happen in cases of syntax errors.
- Examples:
 - Code values different from the numbers 0 to 9.
 - Separation character different from " = ", etc.

13.2.3 MVW-01 Special Parameters

In general, the parameters of an inverter store their information in 16-bit words. To know the contents of one of these parameters through a communication network (serial, fieldbus, etc.), the number of the parameter must be informed (according to the used protocol) and a 16-bit information will be received as the answer, because there is only one information word associated for each parameter.

Some of the MVW-01 parameters have more than one word of associated information, so that the access to these parameters is done in a special manner. These parameters are:

- Parameters of the last errors: P014 to P017, P060 to P065 - 3 words per parameter.
- Date and Time: P080 and P081 - 2 words per parameter.
- Error log: P067 - 300 words.
- Trace function data: P555, P557, P559, P561, P563, P565, P567, P569 – up to 31080 words per parameter.

To gain access to the contents of these special parameters, successive readings must be performed until all the words associated to that parameter have been obtained (the readings must be done normally, according to the specified protocol), remembering that in each reading the access to only one word (16 bits) is obtained.

NOTE! While reading special parameters, this reading should be done in an uninterrupted form, reading the same parameter repeated times without reading any other parameter in between until all the readings of the special parameter associated words have been accomplished. If another parameter is read before the conclusion of the reading of all the words, then when it is read again it sends the first associated word again.

Parameters of the Last Errors

The parameters that bring the information of the 10 last errors (P014 to P017, P060 to P065) have three words associated to each one of them.

The first read word brings the information of the occurred error number and of the inverter status at the moment it occurred. The information is distributed among the word bits in the following way:

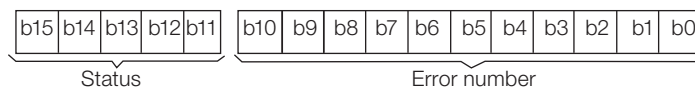

The second and the third words bring the information of the date/time when the error happened. The date/time information has 32 bits and two words are necessary to represent it.

In order to decode the date/time information, refer to the [Item 13.2.1 Protocol Definitions on page 13-15](#).

For instance, in order to obtain the information of the last error (P014 = read P014 three consecutive times).

Date and Time Parameters.

The MVW-01 inverter has a real time clock with the purpose of recording date and time of events as, for instance, the occurred errors. Date and time can be adjusted through the parameters P080 and P081, respectively.

NOTE! Date and time can only be modified through the local HMI.

Despite having two parameters related with the date and hour, the information is stored in a single 32-bit variable. Thus, to obtain the inverter date and time information, two readings of P080 are necessary, since the information is stored in 32 bits, i.e., in two words.

In the first reading the inverter sends the most significant word (bits 16 to 31) and in the second reading the less significant word (bits 0 to 15).

Those 32 bits of information contain the counting of the seconds elapsed since 00:00 a.m. of January 1st, 1970. A Julian codifying routine must be used to determine the date and the hour correspondent the this counting.

Error Log Parameter.

The parameter P067 has the information of the 100 last inverter errors. Since each error has 3 words (48 bits) of associated information, this parameter has 300 words.

Therefore, the first three readings of P067 supply the information of the last error, the three following readings of the next one, and so on until 300 readings are done. For information on the words related to an error, refer to the [Item 13.2.1 Protocol Definitions on page 13-15](#).

Trace Function Data Parameters.

The trace function stores an enormous amount of information in each of its channels. To get access to this data, it is necessary to read the parameter related to the wanted channel (P555, P557, P559, P561, P563, P565, P567, P569).

When the first reading of a certain channel parameter is done, it responds with the number of the corresponding parameter programmed for trace.

Starting from the second reading on (in sequence), the information recorded by the trace function is sent. In order to know how many words are associated to each channel, refer to the [Section 12.1 Trace Function on page 12-1](#).

Times for Telegram Reading/Writing.

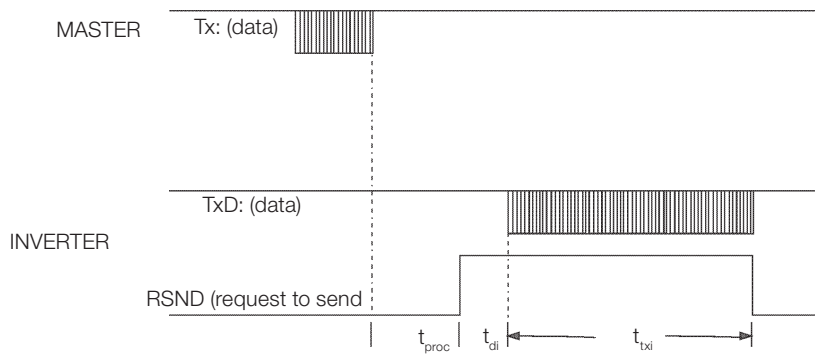

Figure 13.12: Time of the telegrams exchanged between Master and Inverter

Table 13.9: Reading and writing time

Time	Typical (ms)	
T_{proc}	10	
T_{di}	5	
T_{txi}	Reading	15
	Writing	3

13.2.4 RS-232 and RS-485 Physical Connection

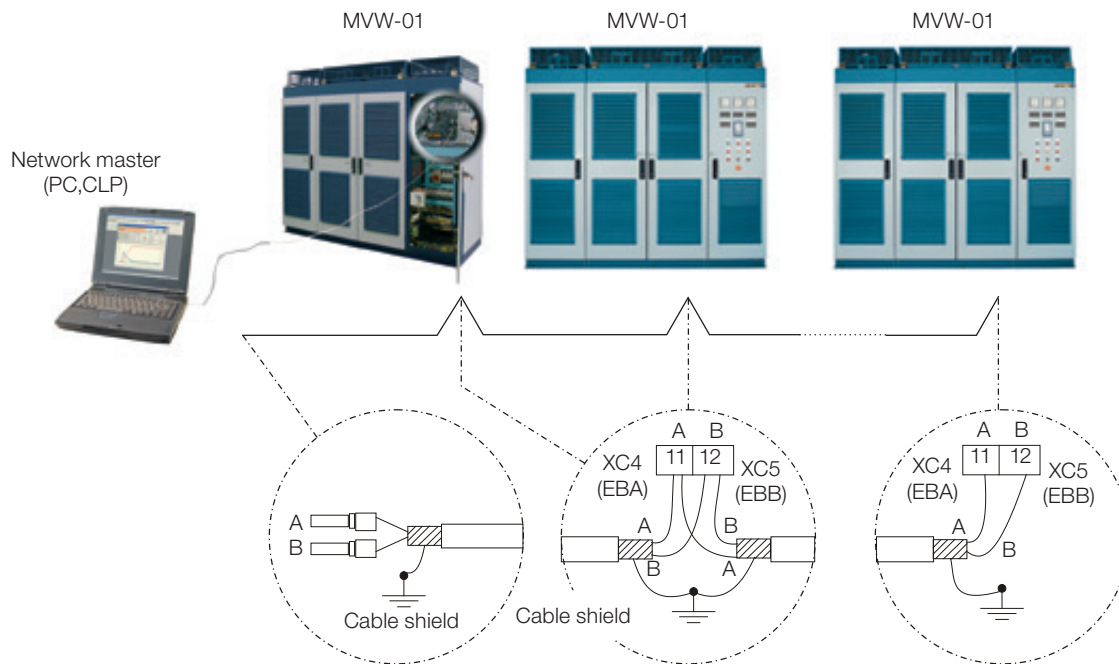

Figure 13.13: Connection Scheme

Notes:

- LINE TERMINATION: add a line termination (120 Ω) at the ends, and only at the ends, of the line. Therefore, set S3.1/S3.2 (EBA) and S7.1/S7.2 (EBB) in the on position (refer to the [Item 10.2.1 EBA \(I/O Expansion Board A\)](#) on page 10-5 and [Item 10.2.2 EBB \(I/O Expansion Board B\)](#) on page 10-8).
- CABLE SHIELD GROUNDING: connect them to the equipment frames (properly grounded).
- RECOMMENDED CABLE: balanced pair, shielded.
- E.g., AFS Line, manufacturer KMP.

- The RS-485 network wiring must be separated from power cables and 110/220 V command.
- The reference signal for the RS-485 interface (SREF) should be used if the master of the network is not referenced to the ground used in the installation. For instance, in case the master is fed by an isolated power supply, it is necessary to ground that power supply reference, or take this reference signal to the rest of the system. Normally, it is only necessary to connect the A (-) and B (+) signals, without the connection of the SREF signal.

RS-232 Serial Interface Module.

The MVW-01 serial interface connection is available at the MVC4 board XC7 connector (refer to the physical position in [Figure 10.1 on page 10-1](#)).

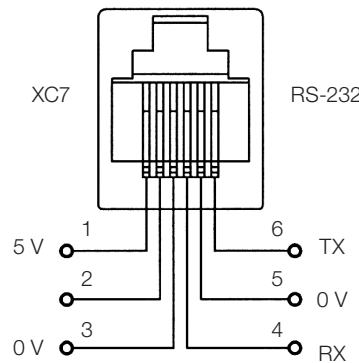

Figure 13.14: XC7 (RJ12) connector signal description



NOTE!

- The RS-232 wiring must be separated from power cables and 110/220 V command.
- It is not possible to use RS-232 and RS-485 simultaneously.

13.3 MODBUS-RTU

13.3.1 Introduction to the Modbus-RTU Protocol

The Modbus protocol was initially developed in 1979. Nowadays it is an open protocol, widely spread and used by many manufacturers in several equipments. The MVW-01 Modbus-RTU communication was developed based in two documents:

1. MODBUS Protocol Reference Guide Rev. J, MODICON, June 1996.
2. MODBUS Application Protocol Specification, MODBUS.ORG, may 8th 2002.

These documents define the format of the messages used by the elements that compose the Modbus network, the services (or functions) that can be made available through the network, and how these elements exchange date in the network.

13.3.1.1 Transmission Modes

Two transmission modes are defined in the protocol specification: ASCII and RTU. The modes define how the bytes of the message are transmitted. It is not possible to use both transmission modes in the same network.

In the RTU mode each transmitted package has 1 start bit, eight data bits, 1 parity bit (optional) and 1 stop bit (2 stop bits if the parity bit is not used). Therefore, the bit sequence for the transmission of one byte is the following:

Start	B0	B1	B2	B3	B4	B5	B6	B7	Parity or Stop	Stop
-------	----	----	----	----	----	----	----	----	----------------	------

In the RTU mode each data byte is transmitted as being a single word directly with its value in hexadecimal. The MVW-01 uses only this transmission mode for communication, not having therefore, the ASCII communication mode.

13.3.1.2 RTU Mode Message Structure

The Modbus-RTU network operates in the master-slave system, where up to 247 slaves may exist, but with just one master. Every communication begins with the master doing a request to a slave, and then the slave responds to the master what had been requested. In both telegrams (request and response), the used structure is the same: address, function code, data and CRC. Only the data field may have a changeable size, depending on what is being requested.

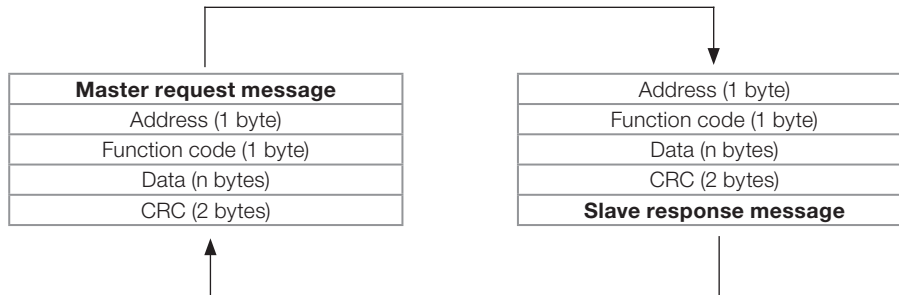

Figure 13.15: Telegram structure

Address:

The master initiates the communication by sending one byte with the address of the slave to which the message is destined.

By sending the response, the slave also initiates the message with its own address. The master can also send a message destined to address 0 (zero), which means that the message is intended to all network slaves (broadcast). In this case, no slave will answer to the master.

Function Code:

This field contains a single byte, where the master specifies the type of service or function requested to the slave (reading, writing, etc.). According to the protocol, each function is used to access a specific data type.

In the MVW-01 all data are available as holding type registers (referenced from the address 40000 or '4x'). Besides these registers, the inverter status (enabled/disabled, with or without error, etc.) and the command for the inverter (Start/Stop, Forward/Reverse, etc.) can be also accessed through the coil read/write functions, or the internal bits (referenced from the address 00000 or '0x' on).

Data Field:

This field has a variable length. The format and the content of this field depend on the used function and the transmitted values. This field is described together with the functions (refer to the [Item 13.3.3 Detailed Description of the Functions on page 13-29](#)).

CRC:

The last part of the message is the field for checking transmission errors. The used method is the CRC-16 (Cycling Redundancy Check). This field is formed by two bytes, where the least significant byte (CRC-) is transmitted first, and then the most significant byte is transmitted (CRC+).

CRC calculation is started by loading a 16-bit variable (mentioned from now on as CRC variable) with FFFFh value. The next steps are executed according to the following routine:

1. The first message byte (Only the data bits. Start bit, parity bit and stop bit are not used) is submitted to an XOR logic (exclusive OR) with the 8 least significant bits of the CRC variable, returning the result to the CRC variable.
2. Then the CRC variable is shifted one position to the right, in the direction of the least significant bit and the position of the most significant bit is filled with 0 (zero).
3. After this shift, the flag bit (bit that has been shifted out the CRC variable) is analyzed, resulting in the following:
 - If the bit value is 0 (zero), no change is made.
 - If the bit value is 1, the CRC variable content is submitted to XOR logic with a constant value A001h, and the result is returned to the CRC variable.

4. Repeat steps 2 and 3 until eight shifts have been done.
5. Repeat the steps 1 to 4, by using the next message byte until the whole message have been processed.

The final content of the CRC variable is the CRC field value that is transmitted at the end of the message. The least significant part is transmitted first (CRC-), and then the most significant part (CRC+) is transmitted.

Time between Messages:

In the RTU mode, there is no specific character indicating the beginning or the end of a telegram. Therefore, what indicates when a new message starts or when it finishes is the absence of data transmission in the network, during a minimum period of 3.5 times the transmission time of a data word (11 bits). Therefore, if a telegram has initiated after the minimum time without transmission has elapsed, the network elements will assume that the received character represent the beginning of a new telegram. And in the same way, the network elements will assume that the telegram has reached the end after lapsing this time elapses again.

If during the transmission of a telegram, the time between bytes is greater than this minimum time, the telegram will be considered invalid, because the inverter is going to discard the already received bytes and it will assemble a new telegram with the bytes that are being transmitted.

The following table shows the times for three different baudrates.

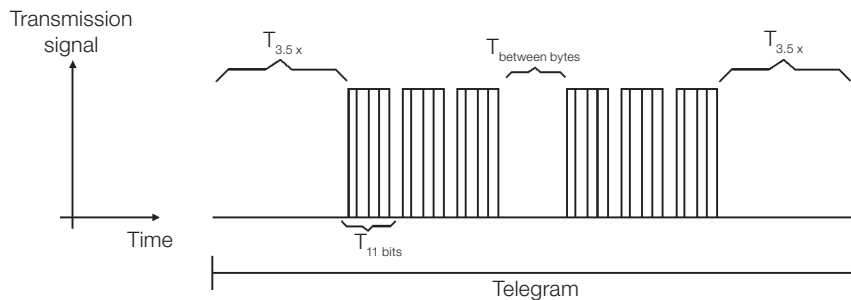

Figure 13.16: Time between bytes in a telegram transmission

Table 13.10: Telegram transmission time

Baudrate	T _{11 bits}	T _{3.5x}
9600 kbits/sec	1.146 ms	4.010 ms
19200 kbits/sec	573 μs	2.005 ms
38400 kbits/sec	285 μs	1.003 ms

T_{11 bits} = time to transmit one word of the message.
 T_{between bytes} = time between bytes (cannot be longer than T_{3.5x}).
 T_{3.5x} = minimum interval indicating the begin and the end of the message (3.5 x T_{11bits}).

13.3.2 Operation of the MVW-01 in the Modbus-RTU Network

The MVW-01 frequency inverters operate as Modbus-RTU network slaves, and all the communication initiates with the Modbus-RTU network master requesting some service to a network address.

If the inverter is configured for the corresponding address, then it processes the request and responds what was asked to the master.

RS-232 and RS-485 Interface Description

The MVW-01 frequency inverters use a serial interface to communicate with the Modbus-RTU network. There are two possibilities for the physical connection between the network master and an MVW-01:

RS-232:

- The interface is used for a point-to-point connection (between a single slave and the master).
- Maximum distance: 10 meters.
- Signal levels according to EIA STANDARD RS-232C.

Three wires: transmission (TX), reception (RX) and return (0V).

RS-485:

- This interface is used for multipoint connection (several slaves and the master).
- Maximum distance: 1000 meters (using shielded cables).
- Signal levels according to EIA STANDARD RS-485.
- The EBA or the EBB expansion board, which have interface for the RS-485 communication, must be used.

Note: refer to the [Item 13.2.4 RS-232 and RS-485 Physical Connection on page 13-22](#) which describes how to make the physical connection.

Inverter Configurations in the Modbus-RTU Network

In order that the inverter be able to communicate properly in the network, besides the physical connection, it is necessary to configure the inverter address, as well as the baudrate and the type of existent parity.

Inverter address in the Network:

It is defined through the parameter 308.

- If the type of serial communication (P312) is configured for Modbus-RTU, it is possible to select addresses from 1 to 247.
- Each slave in the network must have an address different from the others.
- The network master does not have an address.
- It is necessary to know the address of the slave even when the connection is point-to-point.

Baudrate and Parity:

- Both configurations are defined through the parameter P312.
- Baudrates: 9600, 19200 or 38400 kbits/sec.

Parity: None, Odd Parity or Even Parity.

- All slaves, and also the network master, must use the same baudrate and parity.

Access to the Inverter Data

Through the network, it is possible to access all the parameters and basic variables available for the MVW-01:

- Parameters: they are those existing in the inverters, whose visualization and modification is possible through the Human-Machine Interface (HMI) (refer to the Parameter Quick Reference).
- Basic Variables: they are internal inverter variables, and they can only be accessed via serial communication. It is possible through the basic variables, for instance, to change the speed reference, read the status, enable or disable the inverter, etc. (refer to the [Item 13.2.2 Variable Code on page 13-16](#)).
- Register: name used to represent either parameters or the basic variables during the data transmission.
- Internal Bits: they are bits accessed only by the serial, used for the inverter command and status monitoring.

The [Item 13.2.1 Protocol Definitions on page 13-15](#) defines the parameter and variable resolutions when transmitted via serial.

Available functions and response times:

In the Modbus-RTU protocol specification it is defined the functions used to access the type of registers described in the specification. In the MVW-01, parameters and basic variables were defined as being holding type registers (referenced as 4x). Besides these registers, it is also possible to access directly internal command and monitoring bits (referenced as 0x). To access these bits and registers, the next services (or functions) for the MVW-01 frequency inverters were made available:

Read Coils

Description: reading of internal bit blocks or coils.

Function code: 01.

Broadcast: not supported.

Response time: 5 to 10 ms.

Read Holding Registers

Description: reading of register blocks of the holding type.

Function code: 03.

Broadcast: not supported.

Response time: 5 to 10 ms.

Write Single Coil

Description: writing in a single internal bit or coil.

Function code: 05.

Broadcast: supported.

Response time: 5 to 10 ms.

Write Single Register

Description: writing in a single register of the holding type.

Function code: 06.

Broadcast: supported.

Response time: 5 to 10 ms.

Write Multiple Coils

Description: writing in internal bit blocks or coils.

Function code: 15.

Broadcast: supported.

Response time: 5 to 10 ms.

Write Multiple Registers

Description: writing in register blocks of holding type.

Function code: 16.

Broadcast: supported.

Response time: 10 to 20 ms for each written register.

Read Device Identification

Description: Identification of the inverter model.

Function code: 43.

Broadcast: not supported.

Response time: 5 to 10 ms.

Note: Modbus-RTU network slaves are addressed from 1 to 247. The master uses the address 0 to send messages that are destined to all slaves (broadcast).

Data Addressing and Offset:

The data addressing in the MVW-01 is done with offset equal to zero, meaning that the number of the address is equal to the given number. The parameters are made available starting from the address 0 (zero), while the basic variables are made available starting from the address 5000. In the same way, the status bits are made available starting from the address 0 (zero) and the command bytes are made available beginning from the address 100.

The following table illustrates the addressing of bits, parameters and basic variables:

Table 13.11: Addressing of bits, parameters and basic variables

Parameters		
Parameter Number	Modbus Address	
	Decimal	Hexadecimal
P000	0	00h
P001	1	01h
⋮	⋮	⋮
P100	100	64h
⋮	⋮	⋮

Basic Variables		
Variable Number	Modbus Address	
	Decimal	Hexadecimal
V00	5000	1388h
V01	5001	1389h
⋮	⋮	⋮
V08	5008	1390h

Status Bits		
Bit Number	Modbus Address	
	Decimal	Hexadecimal
Bit 0	00	00h
Bit 1	01	01h
⋮	⋮	⋮
Bit 7	07	07h

Command Bits		
Bit Number	Modbus Address	
	Decimal	Hexadecimal
Bit 100	100	64h
Bit 101	101	65h
⋮	⋮	⋮
Bit 107	107	6Bh

Note: All the registers (parameters and basic variables) are treated as holding type registers, referenced starting from 40000 or 4x, while the bits are referenced starting from 0000 or 0x.

The status bits have the same functions of the bits 8 to 15 of the Status (basic variable 2). These bits are available just for reading, and any writing command returns an error to the master.

Table 13.12: Status Bit

Status Bit	
Bit Number	Function
Bit 0	0 = Enable by ramp inactive 1 = Enable by ramp active
Bit 1	0 = General Enable inactive 1 = General Enable active
Bit 2	0 = Reverse 1 = Forward
Bit 3	0 = JOG inactive 1 = JOG active
Bit 4	0 = Local 1 = Remote
Bit 5	0 = No undervoltage 1 = Undervoltage
Bit 6	No function
Bit 7	0 = No error 1 = Error

The command bits are available for reading and writing, and have the same function of the bits 0 to 7 of the Control Word (basic variable 3), without the necessity, however, of the mask use. Writing in the basic variable 3 has influence in the state of these bits.

Table 13.13: Command Bits

Command Bit	
Bit Number	Function
Bit 100	0 = Disable ramp (Stop) 1 = Enable ramp (Run)
Bit 101	0 = General Disable 1 = General Enable
Bit 102	0 = Deactivates the General Enable (motor coasts) 1 = Activates the General Enable
Bit 103	0 = Deactivates JOG 1 = Activates JOG
Bit 104	0 = Go to Local mode 1 = Go to Remote mode
Bit 105	No function
Bit 106	No function
Bit 107	0 = Does not reset the inverter 1 = Resets the inverter

13.3.3 Detailed Description of the Functions

This item presents a detailed description of functions available at the MVW-01 for Modbus-RTU communication. In order to elaborate the telegrams, it is important to observe the following:

- The values are always transmitted in hexadecimal format.
- The address of one piece of data, the number of data and the value of the registers, are always represented in 16 bits. Therefore, it is necessary to transmit those fields using two bytes (high and low). To access bits, the form to represent a bit depends on the used function.
- Both the request and response telegrams, cannot be longer than 128 bytes.
- The resolution of each parameter or basic variable is as described in the [Item 13.2.1 Protocol Definitions on page 13-15](#).

13.3.3.1 Function 01 - Read Coils

It reads the contents of a group of internal bits that must necessarily be in a numerical sequence. This function has the following structure for the request and response telegrams (the values are always hexadecimal, and each field represents one byte):

Table 13.14: Telegram structure

Request (Master)	Response (Slave)
Slave address	Slave address
Function	Function
Address of the initial bit (byte high)	Field Byte Count (number of data bytes)
Address of the initial bit (byte low)	Byte 1
Number of bits (byte high)	Byte 2
Number of bits (byte low)	Byte 3
CRC-	etc to
CRC+	CRC-
-	CRC+

Each response bit is placed at a position of the data bytes sent by the slave. The first byte, from the bits 0 to 7, receives the first 8 bits from the initial address indicated by the master. The other bytes (if the number of the read bits is greater than 8) remain in the same sequence. If the number of the read bits is not a multiple of 8, the remaining bits of the last byte must be filled with 0 (zero).

Example: reading the status bits for general enable (bit 1) and Forward/Reverse (bit 2) of then MVW-01 at the address 1:

Table 13.15: Example of telegram structure

Request (Master)		Response (Slave)	
Field	Value	Field	Value
Slave address	01h	Slave address	01h
Function	01h	Function	01h
Initial byte address (byte high)	00h	Byte Count	01h
Initial byte address (byte low)	01h	Status of bits 1 and 2	02h
Number of bits (byte high)	00h	CRC-	D0h
Number of bits (byte low)	02h	CRC+	49h
CRC-	ECh	-	-
CRC+	0Bh	-	-

As the number of read bits in the example is smaller than 8, the slave required only 1 byte for the response. The value of the byte was 02h, which as binary value will have the form 0000 0010. As the number of read bits is equal to 2, only the two less significant bits, that have the value 0 (General Enable inactive) and 1 (Forward) are of interest. The other bits, as they had not been requested, are filled out with 0 (zero).

13.3.3.2 Function 03 - Read Holding Register

It reads the contents of a group registers that must necessarily be in a numerical sequence. This function has the following structure for the request and response telegrams (the values are always hexadecimal, and each field represents one byte):

Table 13.16: Telegram structure

Request (Master)	Response (Slave)
Slave address	Slave address
Function	Function
Address of the initial register (byte high)	Campo Byte Count
Address of the initial register (byte low)	Data 1 (high)
Number of registers (byte high)	Data 1 (low)
Number of registers (byte low)	Data 2 (high)
CRC-	Data 2 (low)
CRC+	etc
-	CRC-
-	CRC+

Example: Reading of the motor speed (P002) and motor current (P003) from the MVW-01 at the address 1:

Table 13.17: Example of telegram structure

Request (Master)		Response (Slave)	
Field	Value	Field	Value
Slave address	01h	Slave address	01h
Function	03h	Function	03h
Initial register (byte high)	00h	Byte Count	04h
Initial register (byte low)	02h	P002 (high)	05h
Number of registers (byte high)	00h	P002 (low)	84h
Number of registers (byte low)	02h	P003 (high)	00h
CRC-	65h	P003 (low)	35h
CRC+	CBh	CRC-	7Ah
-	-	CRC+	49h

13

Each register is always formed by two bytes (high and low). For the example, we have P002 = 0384h, that in decimal number is equal to 900. As this parameter does not have a decimal place, the actual read value is 900 rpm.

In the same way we will have a motor current value at P003 = 0035h, which corresponds to 53 decimal. As the current has one decimal digit resolution, the read value is 5.3 A.

13.3.3.3 Function 05 - Write Single Coil

This function is used to write a value to a single bit. The bit value is represented by using two bytes, where FF00h represents the bit that is equal to 1, and 0000h represents the bit that is equal to 0 (zero). It has the following structure (the values are always hexadecimal, and each field represents one byte):

Table 13.18: Telegram structure

Request (Master)	Response (Slave)
Slave address	Slave address
Function	Function
Bit address (byte high)	Bit address (byte high)
Bit address (byte low)	Bit address (byte low)
Bit value (byte high)	Bit value (byte high)
Bit value (byte low)	Bit value (byte low)
CRC-	CRC-
CRC+	CRC+

Example: to activate the start command (bit 100 = 1) of an MVW-01 at the address 1:

Table 13.19: Example of telegram structure

Request (Master)		Response (Slave)	
Field	Value	Field	Value
Slave address	01h	Slave address	01h
Function	05h	Function	01h
Bit number (byte high)	00h	Bit number (byte high)	01h
Bit number (byte low)	64h	Bit number (byte low)	02h
Bit value (byte high)	FFh	Bit value (byte high)	D0h
Bit value (byte low)	00h	Bit value (byte low)	49h
CRC-	CDh	CRC-	CDh
CRC+	E5h	CRC+	E5h

For this function, the slave response is an identical copy of the request sent by the master.

13.3.3.4 Function 06 - Write Single Register

This function is used to write a value to a single register. This function has the following structure (values are always hexadecimal values, and each field represents one byte):

Table 13.20: Telegram structure

Request (Master)	Response (Slave)
Slave address	Slave address
Function	Function
Register address (byte high)	Register address (byte high)
Register address (byte low)	Register address (byte low)
Value for the register (byte high)	Value for the register (byte high)
Value for the register (byte low)	Value for the register (byte low)
CRC-	CRC-
CRC+	CRC+

Example: Writing a speed reference (basic variable 4) equal to 900 rpm, to an MVW-01 at the address1.

It is useful to remember that the value for the basic variable 4 depends on the used motor type and that the value 8191 is equal to the rated motor speed. In this case, we suppose that the used motor has a rated speed of 1800 rpm, thus the value to be written into the basic variable 4 for a speed of 900 rpm is half of 8191, i.e., 4096 (1000h).

Table 13.21: Example of telegram structure

Request (Master)		Response (Slave)	
Field	Value	Field	Value
Slave address	01h	Slave address	01h
Function	06h	Function	06h
Register (byte high)	13h	Register (byte high)	13h
Register (byte low)	8Ch	Register (byte low)	8Ch
Value (byte high)	10h	Value (byte high)	10h
Value (byte low)	00h	Value (byte low)	00h
CRC-	41h	CRC-	41h
CRC+	65h	CRC+	65h

For this function, the slave response will be again a copy identical to the request made by the master. As already informed above, the basic variables are addressed from 5000, thus the basic variable 4 will be addressed at 5004 (138Ch).

13.3.3.5 Function 15 - Write Multiple Coils

This function allows writing values for a group of bits that must be in numerical sequence. This function can also be used to write a single bit (the values are always hexadecimal, and each field represents one byte).

Table 13.22: Telegram structure

Request (Master)	Response (Slave)
Slave address	Slave address
Function	Function
Initial bit address (byte high)	Initial bit address (byte high)
Initial bit address (byte low)	Initial bit address (byte low)
Number of bits (byte high)	Number of bits (byte high)
Number of bits (byte low)	Number of bits (byte low)
Byte Count Field (number of data bytes)	CRC-
Byte 1	CRC+
Byte 2	-
Byte 3	-
etc to	-
CRC-	-
CRC+	-

The value of each bit that is being sent is placed at a position of the data bytes sent by the master.

The first byte, in the bits 0 to 7, receives the 8 first bits by starting from the initial address indicated by the master.

The other bytes (if the number of written bits is greater than 8) remain in sequence. If the number of inscribed bits is not a multiple of 8, the remaining bits of the last byte must be filled in with 0 (zero).

Example: Writing of the commands for start (bit 100 = 1), general enable (bit 101 = 1) and Reverse speed direction (bit 102 = 0), to an MVW-01 at the address 1:

Table 13.23: Example of telegram structure

Request (Master)		Response (Slave)	
Field	Value	Field	Value
Slave address	01h	Slave address	01h
Function	0Fh	Function	0Fh
Initial bit (byte high)	00h	Initial bit (byte high)	00h
Initial bit (byte low)	64h	Initial bit (byte low)	64h
Number of bits (byte high)	00h	Number of bits (byte high)	00h
Number of bits (byte low)	03h	Number of bits (byte low)	03h
Byte Count	01h	CRC-	54h
Value for the bits	03h	CRC+	15h
CRC-	BEh	-	-
CRC+	9Eh	-	-

As only three bits are being written, the master needed only one byte to transmit the data. The transmitted values are in the three less significant bits of the byte that contains the value for the bits. The other bits of this byte remained with the value 0 (zero).

13.3.3.6 Function 16 - Write Multiple Registers

This function allows writing values to a group of registers that must be in numerical sequence. This function can also be used to write a single register (the values are always hexadecimal values and each field represents one byte).

Table 13.24: Telegram structure

Request (Master)	Response (Slave)
Slave address	Slave address
Function	Function
Initial register address (byte high)	Initial register address (byte high)
Initial register address (byte low)	Initial register address (byte low)
Number of registers (byte high)	Number of registers (byte high)
Number of registers (byte low)	Number of registers (byte low)
Byte Count Field (number of data bytes)	CRC-
Data 1 (high)	CRC+
Data 1 (low)	-
Data 2 (high)	-
Data 2 (low)	-
etc	-
CRC-	-
CRC+	-

Example: Writing an acceleration time (P100) of 1.0 s and a deceleration time (P101) of 2.0 s, to an MVW-01 at the address 20:

Table 13.25: Example of telegram structure

Request (Master)		Response (Slave)	
Field	Value	Field	Value
Slave address	14h	Slave address	14h
Function	10h	Function	10h
Initial register (byte high)	00h	Initial register (byte high)	00h
Initial register (byte low)	64h	Initial register (byte low)	64h
Number of registers (byte high)	00h	Number of registers (byte high)	00h
Number of registers (byte low)	02h	Number of registers (byte low)	02h
Byte Count	04h	CRC-	02h
P100 (high)	00h	CRC+	D2h
P100 (low)	0Ah	-	-
P101 (high)	00h	-	-
P101 (low)	14h	-	-
CRC-	91h	-	-
CRC+	75h	-	-

Considering that the two parameters have a resolution of one decimal place, in order to write 1.0 and 2.0 seconds, the values 10 (000Ah) and 20 (0014h) must be transmitted, respectively.

13.3.3.7 Function 43 - Read Device Identification

It is an auxiliary function, which allows reading the manufacturer name, model and firmware version of the product. It has the following structure:

Table 13.26: Telegram structure

Request (Master)	Response (Slave)
Slave address	Slave address
Function	Function
MEI Type	MEI Type
Read Code	Conformity Level
Object Number	More Follows
CRC-	Next Object
CRC+	Number of Objects
-	Object Code
-	Object Length
-	Object Value
-	CRC-
-	CRC+

The fields are repeated according to the number of objects.

This function allows reading three information categories: Basic, Regular and Extended, and each category is formed by a group of objects. Each object is formed by a sequence of ASCII characters. For the MVW-01 only basic information is available, composed by three objects:

- Object 00 - VendorName: Always 'WEG'.
- Object 01 - ProductCode: Formed by the product code (MVW-01), plus the inverter rated current.
- Object 02 - MajorMinorRevision: it indicates the inverter firmware version in the "VX.XX" format.

The Read Code indicates the information categories being read, and whether the objects are being accessed in a sequence or individually. In the case, the inverter supports the codes 01 (basic information in sequence), and 04 (individual access to the objects).

The remaining fields for MVW-01 have fixed values.

Example: Sequential reading of basic information, starting from the object 00 of an MVW-01 at the address 1:

Table 13.27: Example of telegram structure

Request (Master)		Response (Slave)	
Field	Value	Field	Value
Slave address	01h	Slave address	01h
Function	2Bh	Function	2Bh
MEI Type	0Eh	MEI Type	0Eh
Read Code	01h	Read Code	01h
Object Number	00h	Conformity Level	51h
CRC-	70h	More Follows	00h
CRC+	77h	Next Object	00h
-	-	Number of Objects	03h
-	-	Object Code	00h
-	-	Object Length	03h
-	-	Object Value	'WEG'
-	-	Object Code	01h
-	-	Object Length	0Eh
-	-	Object Value	'MVW-01 7.0A'
-	-	Object Code	02h
-	-	Object Length	05h
-	-	Object Value	'V2.09'
-	-	CRC-	B8h
-	-	CRC+	39h

In this example, the object values were not represented in hexadecimal, but using the corresponding ASCII characters. For the object 00, for instance, the value 'WEG' was transmitted as being three ASCII characters that in hexadecimal have the values 57h (W), 45h (E) and 47h (G).

13.3.4 ModBus RTU Communication Error

Errors may occur in telegram transmission through the network, or in the contents of the received telegrams. According to the type of error, the inverter may or may not send a response to the master:

When the master sends a message to an inverter configured at a specific network address, the inverter will not respond to the master if the following occurs:

- Parity bit error.
- CRC error.
- Timeout between transmitted bytes (3.5 times the transmission time of a 11 bit word).

In the case of a successful reception, during the telegram processing the inverter may detect problems, and send an error message, indicating the type of problem found:

- Invalid function (error code = 1): the requested function has not been implemented for the inverter.
- Invalid data address (error code = 2): the data address (register or bit) does not exist.
- Data value invalid (error code = 3): this error occurs in the following conditions:
 - Value is out of the permitted range.
 - Writing in data that cannot be changed (read-only register, or one that does not allow changing with enabled inverter, or Status Word bits).
 - Writing in a Control Word function that has not been enabled via serial interface.

Error Messages

When any error occurs in the message content (not during the data transfer), the slave must return a message indicating the error type that occurred. The errors that may occur in the MVW-01 during the message processing are invalid function (code 01), invalid data address (code 02), and invalid data value (code 03) errors.

The messages sent by the slave have following structure:

Table 13.28: Telegram structure

Response (Slave)
Slave address
Function code
(with most significant bit to 1)
Error code
CRC-
CRC+

Example: The master requests the slave at address 1 to write in the parameter 89 (inexistent parameter):

Table 13.29: Example of telegram structure

Request (Master)		Response (Slave)	
Field	Value	Field	Value
Slave address	01h	Slave address	01h
Function	06h	Function	86h
Register (high)	00h	Error code	02h
Register (low)	59h	CRC-	C3h
Value (high)	00h	CRC+	A1h
Value (low)	00h	-	-
CRC-	59h	-	-
CRC+	D9h	-	-

14 DIAGNOSTICS AND TROUBLESHOOTING

This chapter assists the user in the identification and correction of possible faults that may occur during the inverter operation. Guidance on the necessary periodical inspections and cleaning of the inverter is also provided.

14.1 ALARMS/FAULTS AND POSSIBLE CAUSES

When faults or alarms are detected, the inverter indicates them on the HMI. Alarms and faults are displayed as AXXX (for alarms) and FXXX (for faults), and “XXX” is the code of the alarm or fault.





If a fault occurs the inverter is disabled, whereas in an alarm event it continues operating normally. In order to restart the inverter after a fault has occurred, it must be reset. The reset can normally be performed in the following manners:



- By pressing the key on the HMI (Manual reset).
- Automatically through P206 setting (Auto-reset).
- Via a digital input: DI3 (P265 = 12) or DI4 (P266 = 12) or DI5 (P267 = 12) or DI6 (P268 = 12) or DI7 (P269 = 12) or DI8 (P270 = 12) or DI9 (P271 = 12) or DI10 (P272 = 12): DI Reset.
- Via network.

The table below defines each alarm/fault code, explains how to reset the faults and shows the possible causes for each one.

Table 14.1: Alarms/faults and possible causes

Group	Indication	Name	Reset	Possible Causes
Power supply	A001	Input transformer secondary low voltage.	■ It resets automatically when the input transformer secondary voltage becomes greater than 80.5 %.	<ul style="list-style-type: none"> ■ The input transformer secondary voltage is less than 80 % of the rated value. ■ Power supply undervoltage. ■ Incorrect settings of the input transformer primary taps.
	A002	Input transformer secondary high voltage.	■ It resets automatically when the input transformer secondary voltage becomes less than 113.5 %.	<ul style="list-style-type: none"> ■ The input transformer secondary voltage is greater than 114 % of the rated value. ■ Power supply overvoltage. ■ Incorrect settings of the input transformer primary taps.
	F003	Input transformer secondary undervoltage.	<ul style="list-style-type: none"> ■ Power-on. ■ Manual (reset key). ■ Autoreset. ■ Digital input. 	<ul style="list-style-type: none"> ■ The input transformer secondary voltage is less than 70 % of the rated value. ■ Power supply undervoltage. ■ Incorrect settings of the input transformer primary taps.
	F004	Input transformer secondary overvoltage.		<ul style="list-style-type: none"> ■ The input transformer secondary voltage is greater than 117 % of the rated value. ■ Power supply overvoltage. ■ Incorrect settings of the input transformer primary taps.
	F006	Input transformer secondary imbalance or phase loss.		<ul style="list-style-type: none"> ■ Phase loss at the power supply. ■ Voltage imbalance greater than 10 % of the rated value.
	F007	Input transformer secondary voltage feedback fault.	■ Contact WEG.	<ul style="list-style-type: none"> ■ Input transformer secondary voltage feedback circuit failure (A9.4 - board ISOX.01 or ISOX11). ■ Fiber optic cables VAB or VBC not connected, inverted or defective.
	A008	Line synchronism time-out.	■ Manual.	<ul style="list-style-type: none"> ■ The line synchronism function did not succeed.

Group	Indication	Name	Reset	Possible Causes
Rectifier	A010	Input rectifier high temperature.	<ul style="list-style-type: none"> It resets automatically when the rectifier temperature becomes lower than 70 °C (158 °F). 	<ul style="list-style-type: none"> The input rectifier temperature is higher than 75 °C (167 °F). High ambient temperature (> 40 °C or 104 °F) and high output current. Defective or blocked fan. Obstructed air inlet filter.
	F011	Input rectifier overtemperature.	<ul style="list-style-type: none"> Power-on. Manual ( /reset key). Autoreset. Digital input. 	<ul style="list-style-type: none"> The input rectifier temperature is higher than 95 °C (203 °F). High ambient temperature (> 40 °C or 104 °F) and high output current. Defective or blocked fan. Obstructed air inlet filter.
	F012	Input rectifier temperature feedback fault.	<ul style="list-style-type: none"> Contact WEG. 	<ul style="list-style-type: none"> Input rectifier temperature feedback circuit failure (A9.1 - ISOY or ISOZ board). Fiber optic not connected, inverted or defective.
Sinusoidal Filter	F013	Feedback missing on sinusoidal filter.	<ul style="list-style-type: none"> Auto-reset. Eliminate cause. 	<ul style="list-style-type: none"> Contactor of sinusoidal filter with fault in the closing or opening. Defect in the DI/DO connections of the drive and feedback function of the circuit breaker of the sinusoidal filter.
Input circuit breaker	F014	Input circuit breaker closing failure.	<ul style="list-style-type: none"> Power-on. Manual ( /reset key). Autoreset. Digital input. 	<ul style="list-style-type: none"> The not closing of the input circuit breaker when commanded. Defective circuit breaker. Open wiring at the PIC board DI3 (XC7:3) input (+24 V closing checkback signal is not present).
	F015	Input circuit breaker opening failure.		<ul style="list-style-type: none"> The not opening of the input circuit breaker when commanded. Defective circuit breaker. Open wiring at the PIC board DI4 (XC7:4) input (+24 V opening checkback signal is not present).
	F016	External trip by circuit breaker protection.	<ul style="list-style-type: none"> User password. Power-on. Manual ( /reset key). Autoreset. Digital input. 	<ul style="list-style-type: none"> Open wiring at the PIC board DI5 (XC7:5) input (+24 V signal is not present). Trip of the external protection related to the inverter input transformer.
	F017	Input circuit breaker not ready.	<ul style="list-style-type: none"> Power-on. Manual ( /reset key). Autoreset. Digital input. 	<ul style="list-style-type: none"> The circuit breaker was not ready when it was commanded to close. Defective circuit breaker. An attempt to switch on the circuit breaker through DI1, while DO1 is indicating that the inverter is not capable of closing it.
Input transformer	A018	Input transformer alarm.	<ul style="list-style-type: none"> It resets automatically when the input transformer alarm ceases existing. 	<ul style="list-style-type: none"> The PIC board DI11 (XC7:16) input is active with +24 V applied. Verify the cause at the transformer.
	F019	Input transformer fault.	<ul style="list-style-type: none"> Power-on. Manual ( /reset key). Autoreset. Digital input. 	<ul style="list-style-type: none"> The PIC board DI12 (XC8:1) input is active with +24 V applied. Verify the cause at the transformer.
DC Link	F020	Pre-charge Fault.		<ul style="list-style-type: none"> The DC link voltage has not increased in the specified time. Incorrect primary tap setting of the command transformer T1. Auxiliary power supply phase loss. Open pre-charge circuit fuse F1. Failure of the pre-charge contactors K1 or K4. Auxiliary supply with low voltage.
	F021	DC link undervoltage (Positive or Negative).		<ul style="list-style-type: none"> Supply voltage too low, causing voltage on the DC link below the minimum value (80 % of the rated value), or 70 % if in vector or scalar with Ride-Through. Transformer input phase loss. Parameter P296 adjusted at a voltage higher than the rated line voltage.

Group	Indication	Name	Reset	Possible Causes
DC Link	F022	DC link overvoltage (Positive or Negative).	<ul style="list-style-type: none"> Power-on Manual ( /reset key). Autoreset. Digital input. 	<ul style="list-style-type: none"> The power supply voltage is too high producing a DC link voltage higher than the maximum 130 % of the nominal value. The load inertia is too high or the deceleration ramp is too fast. P151 or P153 setting is too high.
	F023	DC link imbalance.		<ul style="list-style-type: none"> The difference between the positive and the negative DC link voltages > 15 % of the rated value.
	F024	Positive or negative DC link voltage feedback fault.	<ul style="list-style-type: none"> Contact WEG. 	<ul style="list-style-type: none"> DC link voltage feedback circuit failure (Positive or Negative): A9.3 - board ISOX.00 or ISOX.10. Fiber optic cables VP or VN not connected, inverted or defective.
	F025	Door closing fault.	<ul style="list-style-type: none"> Power-on Manual ( /reset key). Autoreset. Digital input. 	<ul style="list-style-type: none"> An attempt to power-up the inverter with open cabinet doors. Open wiring at the PIC board DI16 (XC8:10) input (+24 V indicating closed doors is not present).
	F026	Input circuit breaker not ready.		<ul style="list-style-type: none"> An attempt to power-up the inverter while the input circuit breaker was not ready. Defective circuit breaker. The circuit breaker is indicating, through DI2, that the attempt to close it has failed.
Inverter	F030	U 1 IGBT fault.	<ul style="list-style-type: none"> Contact WEG. 	<ul style="list-style-type: none"> Related to the gate driver fault feedback. IGBT out of the saturation zone. Fiber optic poorly connected or defective.
	F031	U 2 IGBT fault.		
	F032	U 3 IGBT fault.		
	F033	U 4 IGBT fault.		
	F034	V 1 IGBT fault.		
	F035	V 2 IGBT fault.		
	F036	V 3 IGBT fault.		
	F037	V 4 IGBT fault.		
	F038	W 1 IGBT fault.		
	F039	W 2 IGBT fault.		
	F040	W 3 IGBT fault.		
	F041	W 4 IGBT fault.		
	F042	Braking IGBT 1 fault.		
	F043	Braking IGBT 2 fault.		
	F044	Arc detection.	<ul style="list-style-type: none"> Electrical arcing detection by cabinet sensors. 	
	F045	PS1/PS1S power supply fault.	<ul style="list-style-type: none"> Problem with the PS1 power supply, located in the rectifier column. Fiber optic cable not connected, inverted or defective. 	
	A046	Motor I x t overload alarm.	<ul style="list-style-type: none"> It resets automatically when the overload status value (P076) becomes lower than P159. 	<ul style="list-style-type: none"> The P159 setting is too low for the used motor. Too heavy load at the motor shaft. P136 and P137 settings are too high (valid for low speed operation).
	F047	IGBT overload fault.	<ul style="list-style-type: none"> Manual. 	<ul style="list-style-type: none"> A high current transitory occurred while the heatsink was with high temperature. Actuation of the fault at 120 °C (248 °F).
	F048	Forced ventilation fault.		<ul style="list-style-type: none"> Obstructed fans. Obstructed air inlet filters.
A050	U phase heatsink high temperature.	<ul style="list-style-type: none"> It resets automatically when the U phase heatsink temperature becomes lower than 70 °C (158 °F). 	<ul style="list-style-type: none"> U phase heatsink temperature is higher than 75 °C (167 °F). High ambient temperature (> 40 °C or 104 °F) and high output current. Defective or blocked fans. Obstructed air inlet filters. 	
F051	U phase heatsink overtemperature.	<ul style="list-style-type: none"> Power-on Manual ( /reset key). Autoreset. Digital input. 	<ul style="list-style-type: none"> U phase heatsink temperature is higher than 80 °C (176 °F). High ambient temperature (> 40 °C or 104 °F) and high output current. Defective or blocked fans. Obstructed air inlet filters. 	







Group	Indication	Name	Reset	Possible Causes
Inverter	F052	U phase heatsink temperature feedback fault.	<ul style="list-style-type: none"> Contact WEG. 	<ul style="list-style-type: none"> U phase heatsink temperature feedback circuit failure. Fiber optic cable TEMPV not connected, inverted or defective.
	A053	V phase heatsink high temperature.	<ul style="list-style-type: none"> It resets automatically when the V phase heatsink temperature becomes lower than 70 °C (158 °F). 	<ul style="list-style-type: none"> V phase heatsink temperature is higher than 75 °C (167 °F). High ambient temperature (> 40 °C or 104 °F) and high output current. Defective or blocked fans. Obstructed air inlet filters.
	F054	V phase heatsink overtemperature.	<ul style="list-style-type: none"> Power-on. Manual (O/reset key). Autoreset. Digital input. 	<ul style="list-style-type: none"> V phase heatsink temperature is higher than 80 °C (176 °F). High ambient temperature (> 40 °C or 104 °F) and high output current. Defective or blocked fans. Obstructed air inlet filters.
	F055	V phase heatsink temperature feedback fault.	<ul style="list-style-type: none"> Contact WEG. 	<ul style="list-style-type: none"> V phase heatsink temperature feedback circuit failure. Fiber optic cable TEMPV not connected, inverted or defective.
	A056	W phase heatsink high temperature.	<ul style="list-style-type: none"> It resets automatically when the W phase heatsink temperature becomes lower than 70 °C (158 °F). 	<ul style="list-style-type: none"> W phase heatsink temperature is higher than 75 °C (167 °F). High ambient temperature (> 40 °C or 104 °F) and high output current. Defective or blocked fans. Obstructed air inlet filters.
	F057	W phase heatsink overtemperature.	<ul style="list-style-type: none"> Power-on. Manual (O/reset key). Autoreset. Digital input. 	<ul style="list-style-type: none"> W phase heatsink temperature is higher than 80 °C (176 °F). High ambient temperature (> 40 °C or 104 °F) and high output current. Defective or blocked fans. Obstructed air inlet filters.
	F058	W phase heatsink temperature feedback fault.	<ul style="list-style-type: none"> Contact WEG. 	<ul style="list-style-type: none"> W phase heatsink temperature feedback circuit failure. Fiber optic cable TEMPW not connected, inverted or defective.
	A059	Braking arm high temperature.	<ul style="list-style-type: none"> It resets automatically when the braking arm temperature becomes lower than 70 °C (158 °F). 	<ul style="list-style-type: none"> Braking arm temperature is higher than 75 °C (167 °F). High ambient temperature (> 40 °C or 104 °F) and high output current. Defective or blocked fans. Obstructed air inlet filters.
	F060	Braking arm overtemperature.	<ul style="list-style-type: none"> Power-on. Manual (O/reset key). Autoreset. Digital input. 	<ul style="list-style-type: none"> Braking arm temperature is higher than 80 °C (176 °F). High ambient temperature (> 40 °C or 104 °F) and high output current. Defective or blocked fans. Obstructed air inlet filters.
	F061	Braking arm temperature feedback fault.	<ul style="list-style-type: none"> Contact WEG. 	<ul style="list-style-type: none"> Braking arm temperature feedback circuit failure. Fiber optic cable TEMPBR not connected, inverted or defective.
	F062	Thermal imbalance among the U, V and W phase heatsinks.	<ul style="list-style-type: none"> Power-on. Manual (O/reset key). Autoreset. Digital input. 	<ul style="list-style-type: none"> Temperature difference among the U, V and W phase heatsinks greater than 10 °C (50 °F). High ambient temperature (> 40 °C or 104 °F) and high output current. Defective or blocked fans. Obstructed air inlet filters.
	Power section test	F063	U output voltage feedback fault.	<ul style="list-style-type: none"> For WEG use.
F064		V output voltage feedback fault.		
F065		W output voltage feedback fault.		
Self-tuning/ Test mode	F066	Null current.		
	F068	Test mode.		
	F069	Calibration fault.		

Group	Indication	Name	Reset	Possible Causes
Output/ Motor	F070	Overcurrent/Shortcircuit at the output.	<ul style="list-style-type: none"> ■ Power-on. ■ Manual (/reset key). ■ Autoreset. ■ Digital input. 	<ul style="list-style-type: none"> ■ Instant current in the motor output ≥ 1.8 times the rated current of the inverter (Detection by Hardware). ■ Short-circuit between two motor phases or power cables. ■ Short-circuit between motor cables and the ground. ■ Load inertia is too high or acceleration ramp is too fast. ■ Shorted IGBT modules. ■ Incorrect regulation and/or configuration parameters. ■ P169 setting is too high.
	F071	Overcurrent at the output.		<ul style="list-style-type: none"> ■ High current at the three phases (software detection). ■ Load inertia is too high or acceleration ramp is too fast. ■ Incorrect regulation and/or configuration parameters. ■ P169 setting is too high.
	F072	Motor I x t overload.		<ul style="list-style-type: none"> ■ P156, P157 and P158 settings are too low for the used motor. ■ P136 and P137 settings are too high (valid for low speed operation). ■ Too heavy load at the motor shaft. ■ The output overload fault does not cause the input circuit breaker opening.
	A073	Ground fault alarm.	<ul style="list-style-type: none"> ■ It resets automatically when the cause ceases existing. 	<ul style="list-style-type: none"> ■ Short-circuit to the ground in some point detected by software through the measurement of the feedback signal by fiber optic of the voltage Medium Point (PM) to the ground > 25 %, the sum of the output currents is greater than 10 % of the rated current or current measurement CT defective.
	F074	Ground fault.	<ul style="list-style-type: none"> ■ Manual. ■ Auto-reset. 	<ul style="list-style-type: none"> ■ Time limit, for operation with ground fault has elapsed. ■ The sum of the output currents is greater than 10 % of the rated current. ■ Current measurement CT defective.
	F075	Failure feedback of voltage between the Medium Point (MP) DC Link and ground.	<ul style="list-style-type: none"> ■ Contact WEG. 	<ul style="list-style-type: none"> ■ Failure feedback circuit of voltage between the Ponto-Medio (PM) DC Link and ground (GND). ■ Fiber optic cable not connected, inverted or defective.
	F076	Motor phase loss.	<ul style="list-style-type: none"> ■ Power-on. ■ Manual (/reset key). ■ Autoreset. ■ Digital input. 	<ul style="list-style-type: none"> ■ Bad contact at the motor cables. ■ Current feedback circuit failure.
	F077	Braking resistor overload.		<ul style="list-style-type: none"> ■ The load inertia is too high or the deceleration ramp is too fast. ■ Too heavy load at the motor shaft. ■ P154 and/or P155 programmed incorrectly.
	F078	Motor overtemperature.		<ul style="list-style-type: none"> ■ Deactivation of the digital input programmed for "Motor fault". ■ Actuation of the external thermal relay (Tecsystem or Pextron).
	F079	Encoder fault.	<ul style="list-style-type: none"> ■ Power-on. ■ Manual/automatic. ■ Autoreset. 	<ul style="list-style-type: none"> ■ Interrupted wiring between the encoder and the encoder interface accessory. ■ Defective encoder. ■ Cable length longer than the maximum limit specified. ■ Mounting error of the absolute encoder.

Group	Indication	Name	Reset	Possible Causes	
Control	F080	CPU watchdog fault.	<ul style="list-style-type: none"> ■ Power-on ■ Manual (O/reset key). ■ Autoreset. ■ Digital input. 	<ul style="list-style-type: none"> ■ Electric noise. 	
	F081	Program memory fault.	<ul style="list-style-type: none"> ■ Not implemented. 	<ul style="list-style-type: none"> ■ Not implemented. 	
	F082	Copy function fault.	<ul style="list-style-type: none"> ■ Power-on ■ Manual (O/reset key). ■ Autoreset. ■ Digital input. 	<ul style="list-style-type: none"> ■ An attempt to copy incompatible parameters from the HMI to the inverter. 	
	F083	Programming fault.	<ul style="list-style-type: none"> ■ It resets automatically when the incompatibility between parameters is eliminated. 	<ul style="list-style-type: none"> ■ An attempt to adjust a parameter that is incompatible with the others. Refer to the Table 9.5 on page 9-10. 	
	F084	Auto-Diagnosis fault.	<ul style="list-style-type: none"> ■ Power-on ■ Manual (O/reset key). 	<ul style="list-style-type: none"> ■ Fault in the initialization diagnosis. 	
Electronics	F085	Electronics power supply fault.	<ul style="list-style-type: none"> ■ Manual. ■ Autoreset. 	<ul style="list-style-type: none"> ■ Power supply monitoring signal indicating that the electronics power supplies are not OK. 	
Communication	F087	Control boards communication fault.	<ul style="list-style-type: none"> ■ It resets automatically when the MVC3 and MVC4 boards start communicating again. 	<ul style="list-style-type: none"> ■ MVC3 board serial communication circuit failure. ■ MVC4 board serial communication circuit failure. ■ Fiber optic cables not connected, inverted or defective. 	
Auxiliary circuits	F090	External fault.	<ul style="list-style-type: none"> ■ Manual. ■ Autoreset. 	<ul style="list-style-type: none"> ■ Deactivation of a digital input programmed for No External Fault. 	
	F092	Pre-charge supply fault.	<ul style="list-style-type: none"> ■ Power-on. ■ Manual/automatic. ■ Autoreset. 	<ul style="list-style-type: none"> ■ DC link short-circuit. ■ Open pre-charge circuit breaker. 	
	A093	Rectifier redundant ventilation failure alarm - set A.	<ul style="list-style-type: none"> ■ It resets automatically when the cause ceases existing. 	<ul style="list-style-type: none"> ■ Obstructed fans. ■ Obstructed air inlet filters. ■ Redundant ventilation set A failure alarm (MVC4). 	
	A094	Inverter redundant ventilation failure alarm - set A.		<ul style="list-style-type: none"> ■ Obstructed fans. ■ Obstructed air inlet filters. ■ Redundant ventilation set A failure alarm (MVC4). 	
	F095	PS1 supply fault.		<ul style="list-style-type: none"> ■ Deactivation of the digital input DI8 (XC7:13) of the PLC board. ■ Wiring related to this signal is open (X7:13). 	
A096	4 to 20 mA analog input out of range alarm (less than 3 mA).	<ul style="list-style-type: none"> ■ Analog input signal cable disconnection or rupture. 			
F097	Fault 4...20 mA.	<ul style="list-style-type: none"> ■ Power-on ■ Manual (O/reset key). ■ Autoreset. 		<ul style="list-style-type: none"> ■ Disconnection or breaking of the cable with analog input signal. 	
Others	F098	Help not recorded or Incompatible version.	<ul style="list-style-type: none"> ■ Digital input. 	<ul style="list-style-type: none"> ■ No help recorded or the recorded version is incompatible with the current firmware version of the HMI. 	
	F099	Invalid current offset.	<ul style="list-style-type: none"> ■ Contact WEG. 	<ul style="list-style-type: none"> ■ Current offset out of the allowed range. 	
	F100	MVC3 fatal fault.		<ul style="list-style-type: none"> ■ Invalid CPU addressing. 	
	F101	Incompatible software version between boards.		<ul style="list-style-type: none"> ■ MVC3 software version incompatible with MVC4 version. 	
	F102	Unknown failure in EPLD of MVC3.		<ul style="list-style-type: none"> ■ EPLD invalid fault. 	
	F103	MVC3 RAM fault.		<ul style="list-style-type: none"> ■ SRAM with battery auto-diagnosis fault. 	
	F104	MVC3 A/D failure.		<ul style="list-style-type: none"> ■ A/D auto-diagnosis fault. 	
	F105	MVC3 A/D failure.		<ul style="list-style-type: none"> ■ EEPROM auto-diagnosis fault. 	
	F106	MVC4 fatal fault.		<ul style="list-style-type: none"> ■ Invalid CPU addressing. 	
	A107	Alarm for WEG use.		<ul style="list-style-type: none"> ■ Power-on ■ Manual (O/reset key). 	<ul style="list-style-type: none"> ■ Indicative alarm for WEG use.
	A108	Not initialized inverter alarm.		<ul style="list-style-type: none"> ■ Automatic. 	<ul style="list-style-type: none"> ■ Waiting for the boot conclusion.



Group	Indication	Name	Reset	Possible Causes
Others	F109	MVC3 external general disable fault.	<ul style="list-style-type: none"> ■ Power-on ■ Manual (/reset key). ■ Autoreset. ■ Digital input. 	<ul style="list-style-type: none"> ■ PIC board DI13 input not active (XC8:7).
	A110	Motor overtemperature alarm.	<ul style="list-style-type: none"> ■ It resets automatically when the cause ceases existing. 	<ul style="list-style-type: none"> ■ Deactivation of a digital input programmed for Motor Alarm. ■ External thermal relay actuation (Tecsystem or Pextron).
	A111	External defect alarm.		
	F112	Motor overspeed fault.	<ul style="list-style-type: none"> ■ Manual. 	<ul style="list-style-type: none"> ■ The motor speed is higher than the programmed maximum speed. ■ Refer to the P132.
Auxiliary circuits	A113	Rectifier redundant ventilation failure alarm - set B.	<ul style="list-style-type: none"> ■ It resets automatically when the cause ceases existing. 	<ul style="list-style-type: none"> ■ Obstructed fans. ■ Obstructed air inlet filters. ■ Redundant ventilation set B failure alarm (MVC4).
	A114	Inverter redundant ventilation failure alarm - set B.		<ul style="list-style-type: none"> ■ Obstructed fans. ■ Obstructed air inlet filters. ■ Redundant ventilation set B failure alarm (MVC4).
Mec 2 x D Mec 2 x E	F115	Communication fault between master rack and slave rack.	<ul style="list-style-type: none"> ■ Eliminate the cause. 	<ul style="list-style-type: none"> ■ Fiber optic not connected, inverted or defective (see Figure 6.4 on page 6-3 and Figure 6.5 on page 6-4).
	F116	Slave under fault condition.	<ul style="list-style-type: none"> ■ Autoreset. ■ Eliminate the cause. 	<ul style="list-style-type: none"> ■ One of the slaves in fault. For further details, see the fault description on the HMI of the slave racks.
	F117	Current unbalance between slave drives.	<ul style="list-style-type: none"> ■ Contact WEG. 	<ul style="list-style-type: none"> ■ Defect in the current measurement of the slaves. ■ Defect in the connections of the slaves to the motor. ■ Voltage difference on the DC links of the slave inverters. See the taps of the transformers. ■ Parameterization error.
Control	A123	Programming Alarm.	<ul style="list-style-type: none"> ■ (key /reset). ■ Autoreset. 	<ul style="list-style-type: none"> ■ Alarm occurs when the parameter is set to a value above the limit accepted by the overload duty (P294) according to the inverter rated current (P295); see the manual.
Communication	A124	Parameter change with enabled inverter.	<ul style="list-style-type: none"> ■ Automatic. 	<ul style="list-style-type: none"> ■ Specific Fieldbus/Serial fault.
	A125	Reading/Writing in inexistent parameter.		
	A126	Value out of range.		
	A127	Function not configured for Fieldbus.		
	A129	Inactive Fieldbus connection.	<ul style="list-style-type: none"> ■ It resets automatically when the cause ceases existing. 	
A130	Inactive Fieldbus board.			
Rectifier	A131	Rectifier 1p high temperature.	<ul style="list-style-type: none"> ■ It resets automatically when the rectifier 1p temperature becomes lower than 70 °C (158 °F). 	<ul style="list-style-type: none"> ■ The 1p rectifier temperature is higher than 75 °C (167 °F). ■ High ambient temperature (> 40 °C or 104 °F) and high output current. ■ Defective or blocked fan. ■ Obstructed air inlet filter.
	F132	Rectifier 1p overtemperature.	<ul style="list-style-type: none"> ■ Power-on ■ Manual (/reset key). ■ Autoreset. ■ Digital input. 	<ul style="list-style-type: none"> ■ The input rectifier temperature is higher than 95 °C (203 °F). ■ High ambient temperature (> 40 °C or 104 °F) and high output current. ■ Defective or blocked fan. ■ Obstructed air inlet filter.
	F133	Rectifier 1p temperature feedback fault.	<ul style="list-style-type: none"> ■ Contact WEG. 	<ul style="list-style-type: none"> ■ Fault on the feedback circuit of the temperature of rectifier 1p (ISOY or ISOZ board). ■ Fiber optic cable TEMPRB 1p not connected, inverted or defective.

Group	Indication	Name	Reset	Possible Causes
Inverter	F134	UAp 1 IGBT fault.	■ Contact WEG.	<ul style="list-style-type: none"> ■ Fault on the fault feedback or gate-driver supply. ■ IGBT out of the saturation zone. ■ Fiber optic cable not connected, inverted or defective.
	F135	UAp 2 IGBT fault.		
	F136	UAp 3 IGBT fault.		
	F137	UAp 4 IGBT fault.		
	F138	VAp 1 IGBT fault.		
	F139	VAp 2 IGBT fault.		
	F140	VAp 3 IGBT fault.		
	F141	VAp 4 IGBT fault.		
	F142	WAp 1 IGBT fault.		
	F143	WAp 2 IGBT fault.		
	F144	WAp 3 IGBT fault.		
	F145	WAp 4 IGBT fault.		
	F146 ⁽¹⁾	Braking IGBT 1 B fault.	■ Contact WEG.	<ul style="list-style-type: none"> ■ Related to the gate driver fault feedback, its power supply or the IGBT desaturation. ■ Fiber optic cable not connected, inverted or defective.
	F147 ⁽¹⁾	Braking IGBT 2 B fault.		
	F148	PS1 2 power supply fault.		<ul style="list-style-type: none"> ■ Problem with supply PS1 2. ■ Fiber optic poorly connected, inverted or defective.
	A149	UAp phase heatsink high temperature.	■ It resets automatically when the UAp phase heatsink temperature becomes lower than 70 °C (158 °F).	<ul style="list-style-type: none"> ■ UAp phase heatsink temperature is higher than 75 °C (167 °F). ■ High ambient temperature (> 40 °C or 104 °F) and high output current. ■ Defective or blocked fan. ■ Obstructed air inlet filter.
	F150	UAp phase heatsink overtemperature.	<ul style="list-style-type: none"> ■ Power-on. ■ Manual (/reset key). ■ Autoreset. ■ Digital input. 	<ul style="list-style-type: none"> ■ UAp phase heatsink temperature is higher than 80 °C (176 °F). ■ High ambient temperature (> 40 °C or 104 °F) and high output current. ■ Defective or blocked fan. ■ Obstructed air inlet filters.
F151	Supply fault on the temperature of the UAp phase heatsink.	■ Contact WEG.	<ul style="list-style-type: none"> ■ UAp phase heatsink temperature feedback circuit failure. ■ Fiber optic cable TEMPUPAp not connected, inverted or defective. 	
A152	VAp phase heatsink high temperature.	■ It resets automatically when the VAp phase heatsink temperature becomes lower than 70 °C (158 °F).	<ul style="list-style-type: none"> ■ VAp phase heatsink temperature is higher than 75 °C (167 °F). ■ High ambient temperature (> 40 °C or 104 °F) and high output current. ■ Defective or blocked fan. ■ Obstructed air inlet filters. 	
F153	VAp phase heatsink overtemperature.	<ul style="list-style-type: none"> ■ Power-on. ■ Manual (/reset key). ■ Autoreset. ■ Digital input. 	<ul style="list-style-type: none"> ■ VAp phase heatsink temperature is higher than 80 °C (176 °F). ■ High ambient temperature (> 40 °C or 104 °F) and high output current. ■ Defective or blocked fan. ■ Obstructed air inlet filters. 	
F154	Supply fault on the temperature of the VAp phase heatsink.	■ Contact WEG.	<ul style="list-style-type: none"> ■ VAp phase heatsink temperature feedback circuit failure. ■ Fiber optic cable TEMPVAp not connected, inverted or defective. 	
A155	WAp phase heatsink overtemperature.	■ It resets automatically when the WAp phase heatsink temperature becomes lower than 70 °C (158 °F).	<ul style="list-style-type: none"> ■ WAp phase heatsink temperature is higher than 75 °C (167 °F). ■ High ambient temperature (> 40 °C or 104 °F) and high output current. ■ Defective or blocked fan. ■ Obstructed air inlet filters. 	
F156	WAp phase heatsink overtemperature.	<ul style="list-style-type: none"> ■ Power-on. ■ Manual (/reset key). ■ Autoreset. ■ Digital input. 	<ul style="list-style-type: none"> ■ WAp phase heatsink temperature is higher than 80 °C (176 °F). ■ High ambient temperature (> 40 °C or 104 °F) and high output current. ■ Defective or blocked fan. ■ Obstructed air inlet filters. 	
F157	Supply fault on the temperature of the WAp phase heatsink.	■ Contact WEG.	<ul style="list-style-type: none"> ■ Fault on the feedback circuit of the temperature on the WAp phase heatsink. ■ Fiber optic cable TEMPWAp not connected, inverted or defective. 	

Group	Indication	Name	Reset	Possible Causes
Inverter	A158 ⁽¹⁾	High temperature on the BR B phase heatsink.	<ul style="list-style-type: none"> It resets automatically when the BR B phase heatsink temperature becomes lower than 70 °C (158 °F). 	<ul style="list-style-type: none"> BR B phase heatsink temperature is higher than 75 °C (167 °F). High ambient temperature (> 40 °C or 104 °F) and high output current. Defective or blocked fans. Obstructed air inlet filters.
	F159 ⁽¹⁾	BR B phase heatsink overtemperature.	<ul style="list-style-type: none"> Power-on. Manual ( /reset key). Autoreset. Digital input. 	<ul style="list-style-type: none"> Temperature on the BR B phase heatsink above 80 °C (176 °F). High ambient temperature (> 40 °C or 104 °F) and high output current. Defective or blocked fans. Obstructed air inlet filters.
	F160 ⁽¹⁾	BR B phase heatsink temperature feedback fault.	<ul style="list-style-type: none"> Contact WEG. 	<ul style="list-style-type: none"> U phase heatsink temperature feedback circuit failure. Fiber optic cable TEMPBRB not connected, inverted or defective.
	F161	Thermal imbalance between UAp, VAp and WAp phases.	<ul style="list-style-type: none"> Power-on. Manual ( /reset key). Autoreset. Digital input. 	<ul style="list-style-type: none"> Temperature difference among the UAp, VAp and WAp phase heatsinks greater than 10 °C (50 °F). High ambient temperature (> 40 °C or 104 °F) and high output current. Defective or blocked fan. Obstructed air inlet filters.
Power section test	F162	UAp output voltage feedback fault.	<ul style="list-style-type: none"> For WEG use. 	<ul style="list-style-type: none"> For WEG use.
	F163	VAp output voltage feedback fault.		
	F164	WAp output voltage feedback fault.		
Safety	A165	Safety Stop Active.	<ul style="list-style-type: none"> Power-on. Manual ( /reset key). 	<ul style="list-style-type: none"> Activation of the safety stop function by the customer.
Inverter	F166	Thermal imbalance among the UB, VB and WB phase heatsinks.	<ul style="list-style-type: none"> Power-on. Manual ( /reset key). Autoreset. Digital input. 	<ul style="list-style-type: none"> Temperature difference among the UB, VB and WB phase heatsinks greater than 10 °C (50 °F). Temperature above 40 °C (104 °F) and high output current. Defective or blocked fan. Obstructed air inlet filters.
	F167	Thermal imbalance among the UBp, VBp and WBp phase heatsinks.		<ul style="list-style-type: none"> Temperature difference among the UBp, VBp and WBp phase heatsinks greater than 10 °C (50 °F). Temperature above 40 °C (104 °F) and high output current. Defective or blocked fan. Obstructed air inlet filters.
Rectifier	F168	Rectifier 123 thermal imbalance.	<ul style="list-style-type: none"> Power-on. Manual ( /reset key). Autoreset. Digital input. 	<ul style="list-style-type: none"> Temperature difference between the heatsinks of the rectifiers 1, 2 and 3 or 1p, 2p and 3p above. Temperature above 40 °C (104 °F) and high output current. Defective or blocked fan. Obstructed air inlet filters.
	F169	Rectifier 123p thermal imbalance.		
	A170	Rectifier 2 high temperature.	<ul style="list-style-type: none"> It resets automatically when the rectifier 2 temperature becomes lower than 70 °C (158 °F). 	<ul style="list-style-type: none"> Rectifier 2 temperature is higher than 75 °C (167 °F). Temperature above 40 °C (104 °F) and high output current. Defective or blocked fan. Obstructed air inlet filters.
	F171	Rectifier 2 overtemperature.	<ul style="list-style-type: none"> Power-on. Manual ( /reset key). Autoreset. Digital input. 	<ul style="list-style-type: none"> Rectifier 2 temperature is higher than 95 °C (203 °F). Temperature above 40 °C (104 °F) and high output current. Defective or blocked fan. Obstructed air inlet filters.
	F172	Rectifier 2 temperature feedback fault.	<ul style="list-style-type: none"> Contact WEG. 	<ul style="list-style-type: none"> Input rectifier 2 temperature feedback circuit failure (ISOY board). Fiber optic cable TEMPR2 not connected, inverted or defective.

Group	Indication	Name	Reset	Possible Causes
Rectifier	A173	Rectifier 3 high temperature.	<ul style="list-style-type: none"> It resets automatically when the rectifier 3 temperature becomes lower than 70 °C (158 °F). 	<ul style="list-style-type: none"> Rectifier 3 temperature is higher than 75 °C (167 °F). Temperature above 40 °C (104 °F) and high output current. Defective or blocked fan. Obstructed air inlet filter.
	F174	Rectifier 3 overtemperature.	<ul style="list-style-type: none"> Power-on. Manual (/reset key). Autoreset. Digital input. 	<ul style="list-style-type: none"> Rectifier 3 temperature is higher than 95 °C (203 °F). Temperature above 40 °C (104 °F) and high output current. Defective or blocked fan. Obstructed air inlet filter.
	F175	Rectifier 3 temperature feedback fault.	<ul style="list-style-type: none"> Contact WEG. 	<ul style="list-style-type: none"> Fault on the feedback circuit of the temperature of rectifier 3 (ISOY board). Fiber optic cable TEMPR3 not connected, inverted or defective.
Inverter	F176	IGBT UB 1 fault.	<ul style="list-style-type: none"> Contact WEG. 	<ul style="list-style-type: none"> Failure in the fault feedback or in the gate driver power supply. IGBT out of the saturation zone. Fiber optic cable badly connected or defective.
	F177	IGBT UB 2 fault.		
	F178	IGBT UB 3 fault.		
	F179	IGBT UB 4 fault.		
	F180	IGBT VB 1 fault.		
	F181	IGBT VB 2 fault.		
	F182	IGBT VB 3 fault.		
	F183	IGBT VB 4 fault.		
	F184	IGBT WB 1 fault.		
	F185	IGBT WB 2 fault.		
	F186	IGBT WB 3 fault.		
	F187	IGBT WB 4 fault.		
	F188	PS1 3 power supply fault.		
	A189	UB phase heatsink high temperature.	<ul style="list-style-type: none"> It resets automatically when the UB phase heatsink temperature becomes lower than 70 °C (158 °F). 	<ul style="list-style-type: none"> UB phase heatsink temperature is higher than 75 °C (167 °F). Temperature above 40 °C (104 °F) and high output current. Defective or blocked fan. Obstructed air inlet filter.
F190	UB phase heatsink overtemperature.	<ul style="list-style-type: none"> Power-on. Manual (/reset key). Autoreset. Digital input. 	<ul style="list-style-type: none"> UB phase heatsink temperature is higher than 80 °C (176 °F). Temperature above 40 °C (104 °F) and high output current. Defective or blocked fan. Obstructed air inlet filter. 	
F191	UB phase heatsink temperature feedback fault.	<ul style="list-style-type: none"> Contact WEG. 	<ul style="list-style-type: none"> Fault on the feedback circuit of the temperature on the UB phase heatsink. Fiber optic cable TEMPUB badly connected or defective. 	
A192	VB phase heatsink high temperature.	<ul style="list-style-type: none"> It resets automatically when the VB phase heatsink temperature becomes lower than 70 °C (158 °F). 	<ul style="list-style-type: none"> VB phase heatsink temperature is higher than 75 °C (167 °F). Temperature above 40 °C (104 °F) and high output current. Defective or blocked fan. Obstructed air inlet filter. 	
F193	VB phase heatsink overtemperature.	<ul style="list-style-type: none"> Power-on. Manual (/reset key). Autoreset. Digital input. 	<ul style="list-style-type: none"> VB phase heatsink temperature is higher than 80 °C (176 °F). Temperature above 40 °C (104 °F) and high output current. Defective or blocked fan. Obstructed air inlet filter. 	
F194	VB phase heatsink temperature feedback fault.	<ul style="list-style-type: none"> Contact WEG. 	<ul style="list-style-type: none"> Fault on the feedback circuit of the temperature on the VB phase heatsink. Fiber optic cable TEMPVB badly connected or defective. 	
A195	WB phase heatsink high temperature.	<ul style="list-style-type: none"> It resets automatically when the WB phase heatsink temperature becomes lower than 70 °C (158 °F). 	<ul style="list-style-type: none"> WB phase heatsink temperature is higher than 75 °C (167 °F). Temperature above 40 °C (104 °F) and high output current. Defective or blocked fan. Obstructed air inlet filter. 	

Group	Indication	Name	Reset	Possible Causes
Inverter	F196	WB phase heatsink overtemperature.	<ul style="list-style-type: none"> Power-on. Manual (/reset key). Autoreset. Digital input. 	<ul style="list-style-type: none"> WB phase heatsink temperature is higher than 80 °C (176 °F). Temperature above 40 °C (104 °F) and high output current. Defective or blocked fan. Obstructed air inlet filters.
	F197	WB phase heatsink temperature feedback fault.	<ul style="list-style-type: none"> Contact WEG. 	<ul style="list-style-type: none"> Fault on the feedback circuit of the temperature on the WB phase heatsink. Fiber optic cable TEMPWB badly connected or defective.
Power Test	F198	UB phase output voltage feedback fault.	<ul style="list-style-type: none"> For WEG use. 	<ul style="list-style-type: none"> For WEG use.
	F199	VB phase output voltage feedback fault.		
	F200	WB phase output voltage feedback fault.		
Inverter	F210	UBp 1 IGBT fault.	<ul style="list-style-type: none"> Contact WEG. 	<ul style="list-style-type: none"> Failure in the fault feedback or in the gate driver power supply. IGBT desaturation. Fiber optic cable badly connected or defective.
	F211	UBp 2 IGBT fault.		
	F212	UBp 3 IGBT fault.		
	F213	UBp 4 IGBT fault.		
	F214	VBp 1 IGBT fault.		
	F215	VBp 2 IGBT fault.		
	F216	VBp 3 IGBT fault.		
	F217	VBp 4 IGBT fault.		
	F218	WBp 1 IGBT fault.		
	F219	WBp 2 IGBT fault.		
	F220	WBp 3 IGBT fault.		
	F221	WBp 4 IGBT fault.		
	F222	PS1 4 power supply fault.	<ul style="list-style-type: none"> Problem with supply PS1 4. Fiber optic cable badly connected or defective. 	
	A223	UBp phase heatsink high temperature.	<ul style="list-style-type: none"> It resets automatically when the UBp phase heatsink temperature becomes lower than 70 °C (158 °F). 	<ul style="list-style-type: none"> UBp phase heatsink temperature is higher than 75 °C (167 °F). Temperature above 40 °C (104 °F) and high output current. Defective or blocked fan. Obstructed air inlet filters.
	F224	UBp phase heatsink overtemperature.	<ul style="list-style-type: none"> Power-on. Manual (/reset key). Autoreset. Digital input. 	<ul style="list-style-type: none"> UBp phase heatsink temperature is higher than 80 °C (176 °F). Temperature above 40 °C (104 °F) and high output current. Defective or blocked fan. Obstructed air inlet filters.
	F225	UBp phase heatsink temperature feedback fault.	<ul style="list-style-type: none"> Contact WEG. 	<ul style="list-style-type: none"> UBp phase heatsink temperature feedback circuit failure. Fiber optic cable TEMPUBp badly connected or defective.
A226	VBp phase heatsink high temperature.	<ul style="list-style-type: none"> It resets automatically when the VBp phase heatsink temperature becomes lower than 70 °C (158 °F). 	<ul style="list-style-type: none"> VBp phase heatsink temperature is higher than 75 °C (167 °F). Temperature above 40 °C (104 °F) and high output current. Defective or blocked fan. Obstructed air inlet filters. 	
F227	VBp phase heatsink overtemperature.	<ul style="list-style-type: none"> Power-on. Manual (/reset key). Autoreset. Digital input. 	<ul style="list-style-type: none"> VBp phase heatsink temperature is higher than 80 °C (176 °F). Temperature above 40 °C (104 °F) and high output current. Defective or blocked fan. Obstructed air inlet filters. 	
F228	VBp phase heatsink temperature feedback fault.	<ul style="list-style-type: none"> Contact WEG. 	<ul style="list-style-type: none"> Fault on the feedback circuit of the temperature on the VBp phase heatsink. Fiber optic cable TEMPVBp not connected or defective. 	
A229	WBp phase heatsink high temperature.	<ul style="list-style-type: none"> It resets automatically when the WBp phase heatsink temperature becomes lower than 70 °C (158 °F). 	<ul style="list-style-type: none"> WBp phase heatsink temperature is higher than 75 °C (167 °F). Temperature above 40 °C (104 °F) and high output current. Defective or blocked fan. Obstructed air inlet filters. 	

Group	Indication	Name	Reset	Possible Causes
Inverter	F230	WBp phase heatsink overtemperature.	<ul style="list-style-type: none"> ■ Power-on ■ Manual ( /reset key). ■ Autoreset. ■ Digital input. 	<ul style="list-style-type: none"> ■ WBp phase heatsink temperature is higher than 80 °C (176 °F). ■ Temperature above 40 °C (104 °F) and high output current. ■ Defective or blocked fan. ■ Obstructed air inlet filters.
	F231	WBp phase heatsink temperature feedback fault.	<ul style="list-style-type: none"> ■ Contact WEG. 	<ul style="list-style-type: none"> ■ Fault on the feedback circuit of the temperature on the WBp phase heatsink. ■ Fiber optic cable TEMPWBp not connected or defective.
Power Test	F232	UBp phase output voltage feedback fault.	<ul style="list-style-type: none"> ■ For WEG use. 	<ul style="list-style-type: none"> ■ For WEG use.
	F233	VBp phase output voltage feedback fault.		
	F234	WBp phase output voltage feedback fault.		
DC Link	F236	V DC link imbalance.	<ul style="list-style-type: none"> ■ Power-on ■ Manual ( /reset key). ■ Autoreset. ■ Digital input. 	<ul style="list-style-type: none"> ■ The voltage difference between positive and negative links is greater than 15 % of the nominal value. ■ Fiber optic cables VPV1 or VNV1 badly connected.
	F237	W DC link imbalance.		<ul style="list-style-type: none"> ■ The voltage difference between positive and negative links is greater than 15 % of the nominal value. ■ Fiber optic cables VPW1 or VNW1 badly connected.
	F238	V DC link overvoltage (Positive or Negative).		<ul style="list-style-type: none"> ■ The power supply voltage is too high producing a DC link voltage higher than 130 % of the nominal value. ■ The deceleration ramp is too fast.
	F239	W DC link overvoltage (Positive or Negative).		<ul style="list-style-type: none"> ■ The power supply voltage is too high producing a DC link voltage higher than 130 % of the nominal value. ■ The deceleration ramp is too fast.

14.2 INFORMATION FOR CONTACTING TECHNICAL SUPPORT

 **NOTE!** For technical support or service request, it is important to have the following data available:

- Inverter model.
- Serial number, manufacturing date and hardware revision, which are available on the product identification label (refer to the [Section 1.3 MVW-01 IDENTIFICATION LABEL on page 1-2](#)).
- Software version (refer to the [Section 2.2 SOFTWARE VERSION on page 2-1](#)).
- Application and Programming data.

For explanations, training or services, please, contact WEG Technical Assistance.

14.3 PREVENTIVE MAINTENANCE

 **DANGER!**

- Only trained personnel, with proper qualifications, and familiar with the MVW-01 and associated equipment shall plan and implement the installation, starting, operation, and maintenance of this equipment.
- These personnel shall follow all the safety instructions described in this manual and/or defined by local regulations.
- Failure to comply with the safety instructions may result in death, serious injury, and/or equipment damage.
- WEG Technical Assistance.

**DANGER!**

- Seul un personnel formé, ayant les qualifications adéquates et familiarisé avec le MVW-01 et l'équipement associé peut planifier et mettre en oeuvre l'installation, le démarrage, l'utilisation et la maintenance de cet équipement.
- Ce personnel doit suivre toutes les instructions de sécurité décrites dans ce mode d'emploi et/ou définies par la réglementation locale.
- Le non-respect de ces instructions de sécurité peut entraîner la mort, de graves blessures et/ou des dommages aux équipements.
- WEG l'Assistance Technique.

The MVW-01 inverter has been designed and tested to have a long, failure-free, operation life. The preventive maintenance helps early identification of possible future failures, extending the useful life of the equipment, increasing the mean time between failures and reducing the stopped equipment time. It also helps identifying whether the equipment is being used within its mechanical, electrical and environmental limits. The periodical cleaning during preventive maintenance assures an adequate operation when the inverter is used within its rated conditions.

In order to produce the best benefits, the preventive maintenance must be performed periodically by a qualified technician. The interval depends on factors like the duty cycle and the environmental conditions (ambient temperature, ventilation, the existence of dust, etc.). It is recommended to begin with the preventive maintenance frequently and increase the interval as the obtained results indicate the possibility of reducing that frequency. A detailed record of the preventive maintenance is also recommended. These records serve as proof of the maintenance fulfillment and facilitate the identification of possible faults and alarms.

Two types of preventive maintenance are described next, during the operation of the equipment and with the complete stop/de-energization of the inverter.

14.3.1 Preventive Maintenance During the Operation

This type of maintenance is performed with the inverter energized and in operation. There is necessary access only to the control cabinet where low voltage supply voltages (< 480 V) are present, but which are potentially dangerous.

**DANGER!**

- This equipment has high voltages that may cause electric shocks. Only qualified personnel familiar with the MVW-01 frequency Inverter and associated equipment should plan or implement the maintenance of this equipment. In order to avoid risk of electric shock, follow all the safety procedures required for service on energized equipment.
- Do not touch any electric circuit before making sure it is de-energized.

**DANGER!**

- Seul un personnel formé, ayant les qualifications adéquates et familiarisé avec le MVW-01 et l'équipement associé peut planifier et mettre en oeuvre l'installation, le démarrage, l'utilisation et la maintenance de cet équipement. Ce personnel doit suivre toutes les instructions de sécurité décrites dans ce mode d'emploi et/ou définies par la réglementation locale.
- Le non-respect de ces instructions de sécurité peut entraîner la mort, de graves blessures et/ou des dommages aux équipements.

Procedures:

1. Operation of the fans and exhausting fans:

Verify the proper operation of the exhausting fans at the top of the rectifier cabinet and the inverter cabinet.

The fans must be running in the same direction and their exhausting action must be perceptible.

Verify the proper operation of the fan at the control cabinet. It must be running and blowing air into the cabinet.

2. Cleaning of the air inlet filters:
Remove the protection grids from the air inlets at the doors of all the cabinets by unbolting them. Remove the filters and clean, wash or replace them. The amount of accumulated dirt on the filters helps defining the correct interval between preventing maintenances. Reinstall the filters and bolt the protection grids again.
3. Open the control cabinet and visually inspect the components inside it, verifying them to identify faults or the need of preventive maintenance with complete stop/de-energization for cleaning or replacement:

Table 14.2: Visually inspect

Components	Anomalies
Electronic boards.	Excessive dust, oil, moisture, etc. accumulation. Discolored or darker points, due to excessive heat.
Capacitors on electronic boards.	Discoloration, smell, electrolyte leakage, case deformation.
Resistors in general.	Discoloration or smell.
Control rack (A8), electronics power supply PS24 (A11).	Excessive heating of the aluminum base (more than 40 °C, 104 °F, above the ambient temperature).

4. Read and write down the following from the HMI, P003 - Motor Current, P004 - DC Link Voltage, P005 - Motor Frequency, P006 - Inverter Status, P014 to P017 Last to Fourth Error (get access to the details of each error by pressing the key on the HMI while the parameter is selected), P022 - MVC3 Board Temperature, P042 - Powered Time, P043 - Enabled Time, P055 - U Phase Power Arm Temperature, P056 - V Phase Power Arm Temperature, P057 - W Phase Power Arm Temperature, P058 - Braking Arm Temperature, P059 - Rectifier Temperature, P080 - Date and P081 - Time.

14.3.2 Preventive Maintenance with Complete Stop/De-energization



DANGER!

- This equipment has high voltages that may cause electric shocks. Only qualified personnel familiar with the MVW-01 frequency Inverter and associated equipment should plan or implement the maintenance of this equipment. In order to avoid risk of electric shock, follow all the safety procedures required for service on energized equipment.
- Do not touch any electric circuit before making sure it is de-energized.



DANGER!

- Cet équipement a des tensions élevées pouvant causer des décharges électriques. Seul un personnel qualifié et familier avec l'onduleur de fréquence MVW-01 et ses équipements associés doit préparer et mettre en oeuvre l'entretien de cet équipement. Afin d'éviter un risque de décharge électrique, suivez toutes les procédures de sécurité requises pour l'entretien courant sur un équipement sous tension.
- Ne touchez aucun circuit électrique avant de vous être assuré qu'il est hors tension.

This type of maintenance is also destined for the cleaning and visual inspection of the high voltage cabinets; therefore, it requires the complete de-energization of the inverter. It can be less frequent than the maintenance during operation.

Procedures:

1. Execute the procedures from 1 and 4, of the Preventive Maintenance During Operation.



DANGER!

Although the inverter commands the opening of the input circuit breaker, there is no guarantee of its opening and neither that no voltages are present, because the capacitors remain charged for a long time and they can also be charged through the auxiliary low voltage supply. Before opening and accessing the medium voltage cabinets, follow all the safe de-energization procedures described next.

DANGER!

Bien que l'onduleur commande l'ouverture du coupe-circuit d'entrée, il n'y a aucune garantie qu'il s'ouvrira ni qu'aucune tension n'est présente, car les condensateurs restent chargés pendant longtemps et ils peuvent également être chargés par l'alimentation basse tension auxiliaire. Avant d'ouvrir et d'accéder aux armoires moyenne tension moyenne, suivez toutes les procédures de mise hors tension de sécurité décrites ci-dessous.

14.4 SAFE DE-ENERGIZATION INSTRUCTIONS

1. Decelerate the motor to a complete stop.
2. Check the DC link voltage at the parameter P004 on the HMI. Open the control panel door and locate the neon lamps of the HVM (High Voltage Monitoring board), mounted on the cabinet left side. The four lamps must be on if the voltage showed via P004 is above 200 V.
3. Press the "POWER OFF" pushbutton. The input transformer circuit breaker is switched off at this moment, and the "INPUT ON" pilot light going off indicates it.

ATTENTION!

If the input transformer circuit breaker does not open with the "POWER OFF" command, then open it manually.

4. Follow the DC link voltage decrease through P004 on the HMI and the HVM neon lamps. When the DC link voltage crosses below 200 V the neon lamps start flashing with progressively lower frequency until going off completely. Wait until the DC link voltage displayed at P004 on the HMI gets below 25 V.
5. At the input transformer circuit breaker cubicle, extract the circuit breaker from its operation position and close the transformer primary winding grounding switch. Lock the cubicle with the key and/or put a warning sign "System in maintenance".
6. Press the emergency pushbutton located on the control column door and remove its key.
7. Switch off the Q2 circuit breaker in the control column and lock it in the open position with a padlock and/or put a warning sign "System in maintenance".
8. Switch off the Q1 circuit breaker in the control column. Remove the auxiliary power supply.

It is only after the sequence of procedures described here that medium voltage compartment doors can be opened.

DANGER!

If it were not possible to follow the discharge of the DC link capacitors through the parameter P004, as well as through the HVM board neon lamps, due to a malfunction or a previous, de-energization, follow the instructions 5 through 8 and wait 10 minutes more.

DANGER!

S'il n'était pas possible de suivre la décharge des condensateurs de liaison CC avec le paramètre P004 et les lampes à néon de la carte HVM en raison d'un dysfonctionnement ou une mise hors tension préalable, suivez les instructions 5 jusqu'à 8 et attendez 10 minutes supplémentaires.

9. Execute the procedures 2 and 3 of the Preventive Maintenance During Operation.
10. Clean the dust accumulated in the interior of the control and medium voltage cabinets as described next:
 - Heatsink ventilation system (fans, rectifier and inverter arm heatsinks): remove the dust accumulated on the heatsink fins using compressed air.

- Electronic boards: remove the dust accumulated on the boards using a anti-static brush and/ or low pressure ionized compressed air. If necessary, remove the boards from the inverter.

**ATTENTION!**

Electronic boards have components sensitive to electrostatic discharges. Do not touch directly on components or connectors. If necessary, touch the grounded metallic frame first or use an adequate grounded wrist strap.

- Cabinet inner part and other components: remove the accumulated dust using an vacuum cleaner with a nonmetallic nozzle. Perform this cleaning especially on the insulating materials that support energized parts, to avoid leakage currents during the operation.
11. Connection retightening: inspect all the electrical and mechanical connections and retighten them if necessary.
 12. Reinstall all the removed components and connections in their respective places and follow the start-up procedures described in the [Section 8.3 ENERGIZATION, START-UP AND SAFE DE-ENERGIZATION on page 8-17](#).

14.5 GENERAL WARRANTY CONDITIONS FOR MVW-01 FREQUENCY INVERTERS

Weg Automação S.A, located at Av. Pref. Waldemar Grubba, 3000 in the city of Jaraguá do Sul – SC, provides warranty for defects in material and workmanship for WEG frequency inverters under the following conditions:

- 1.0 For the effectiveness of this warranty, it is essential that the buyer carefully inspects the purchased inverter immediately after its delivery, checking thoroughly its characteristics and installation, setting, operation and maintenance instructions. The inverter will be automatically considered as accepted and approved by the buyer when no written notice is given by the buyer within at most 5 days after the delivery date.
- 2.0 The total length of this warranty is of twelve months from the date of the supply by WEG or authorized dealer, proven through the purchase invoice of the equipment, and limited to twenty four months from the product manufacturing date, which is stated on the label attached to the product.
- 3.0 In case the inverter under warranty does not work properly or does not work at all, the warranty services may be performed during the business hours at WEG's sole discretion, at its headquarters in Jaraguá do Sul - SC, or at an Authorized Service Provider assigned by Weg Automation.
- 4.0 The defective product must be available to the supplier for the required period to detect the cause of the failure and to perform the corresponding repairs.
- 5.0 Weg Automação or an Authorized Service Provider will analyze the returned product, and, if any fault covered under the warranty is observed, they will repair, modify or replace the defective inverter at their own discretion, at not costs to the buyer, except as indicated in [Chapter 14 DIAGNOSTICS AND TROUBLESHOOTING on page 14-1](#).
- 6.0 The responsibility for this warranty is limited exclusively to the repair, modification or replacement of the inverter supplied. Weg takes no liabilities for personal injuries, damages to third parties, other equipment or installations, loss of profits, or any other incidental or consequential damages.
- 7.0 Other expenses, such as freights, packaging, disassembly/assembly and parameterization costs, will be paid exclusively by the buyer, including all working hours, transportation/accommodation and meal expenses for technical personnel, when service is needed and/or requested at the customer's premises.
- 8.0 This warranty neither covers the normal wear of the product or equipment, nor damages resulting from incorrect or negligent operation, incorrect parameterization, improper maintenance or storage, abnormal operation in disagreement with the technical specifications, poor quality installations, or any influence of chemical, electrochemical, electrical, mechanical or atmospheric nature.